

NYMNPA

09/05/2019

From: Mick Paxton
Sent: 09 May 2019 10:08
To: Jill Bastow
Subject: details for the conditions at ox pasture

hi jill - have mentioned the sample panel you need for the conditions and these are the window, door and glazing panels details for the conditions and if you need anything please contact me - regards mick

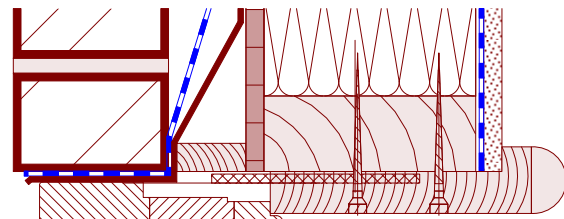

WINDOWS AND DOORS

All windows and doors to be high performance weather rated purpose made timber designed to the approval of the local planning authority (note: habitable rooms opening light size to achieve minimum 1/20 of floor area for rapid ventilation part of which should be 1.75m above floor level)
 All doors to have trickle vents fitted giving background ventilation of not less than 8000mm sq to habitable rooms and 4000mm sq to all other areas

Glazing to doors which is wholly or partially within 1500mm from the floor level to be safety glazing to a minimum Class C and marked accordingly to BS 6206
 Glazing adjacent to doors which is wholly or partially within 300mm of the edge of a door & which is also wholly or partially within 1500mm from the floor level to be safety glazing to a minimum Class C and marked accordingly to BS 6206
 Low level glazing other than glazing in doors and glazing adjacent to doors which is wholly or partially within 800mm from the floor level to be safety glazing to a minimum Class C and marked accordingly to BS 6206
 Note: escape windows to be provided to suit unobstructed openable area that is at least 0.33m² and at least 450mm high and 450mm wide (the route thro' may be at an angle rather than straight thro') the bottom of the openable area should be not more than 1100mm above the floor

internal beads

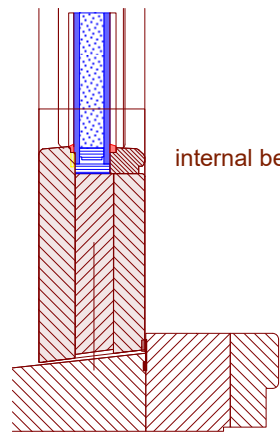

details of the hinged door and frame

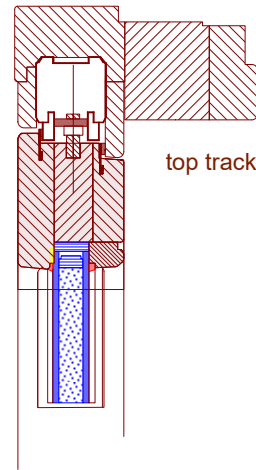

top track

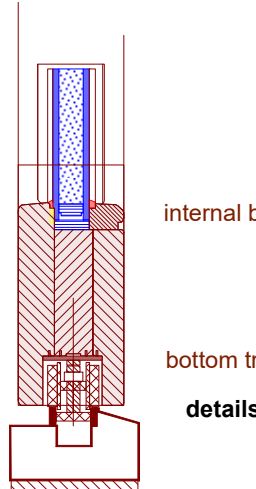

internal beads

bottom track

details of the bi-fold door and frame

doors and frames constructed from triple laminated solid timber sections with espagnolette multipoint locking systems

Timber
 to be treated laminated hardwood and sourced from sustainable sources only and in compliance with the terms required by the British Woodworking Federation BWF Timber Window Accreditation TWA scheme
 All timber to comply with the requirements of BS EN 942 2007.

Preservation
 components to be subjected to preservative treatment by double vacuum pressure impregnation The preservative to be used must meet UK Building Regulations

Glass
 proposed double glazed units to be a 4:16:4 (24mm) argon gas filled unit with softcoat Saint Gobain Low-E glass on the inside leaf, giving a U value of 1.2 W/m2K. The type of edge spacer used within the unit to be warmedge type.
 A toughened/laminated glass is used where necessary to comply with the Building Regulations;

Operation and Ironmongery
 7 lever lock and espagnolette multiple locking mechanism

Ironmongery to be in brushed stainless steel finish

The windows are draught-sealed with gaskets.

WEATHERSHIELD AQUATECH WOODSTAIN - external
DULUX TRADE PROTECTIVE WOODSHEEN - internal
 Surfaces must be sound, clean and dry before treating. if necessary strip back to bare wood.
 Remove and treat any mould, algae, lichen or moss with *Weathershield Multi-Surface Fungicidal Wash.
 Clean the rebates and any loose or open joints.
 Thoroughly rub down all surfaces in the direction of the grain to remove any grey, weathered wood and surface sheen from remaining coatings, and then dust off (refer to your COSHH Assessment).
 Prime all bare wood with 1 coat of ** Weathershield Aquatech Preservative Basecoat+ (BP) including any new or bare replacement beading. Excess basecoat should be wiped off surrounding paintwork.

Mix the ** Weathershield Aquatech Preservative Basecoat+ (BP) thoroughly by shaking the container. Pour out a sufficient amount of primer for the job into a suitable metal container. Do not use direct from the can or return any unused basecoat to the container. Do not thin.
 Fill any surface defects, open joints etc. Do not use linseed oil putty for glazing (or making good) with natural wood finishes, The normal finishing process is 2 coats of Weathershield Aquatech Woodstain.
 When treating timber that has been pressure impregnated with preservative ensure that the surface is completely dry. The use of silicone sealants can cause "cissing" of this product. Do not use on resinous wood or woodwork with a history of blistering. The maximum benefits of this system will only be realised when used as directed above on good quality timber that conforms to BS942: 2007 (or as amended), in conjunction with good component design.

NYMNPA
 09/05/2019

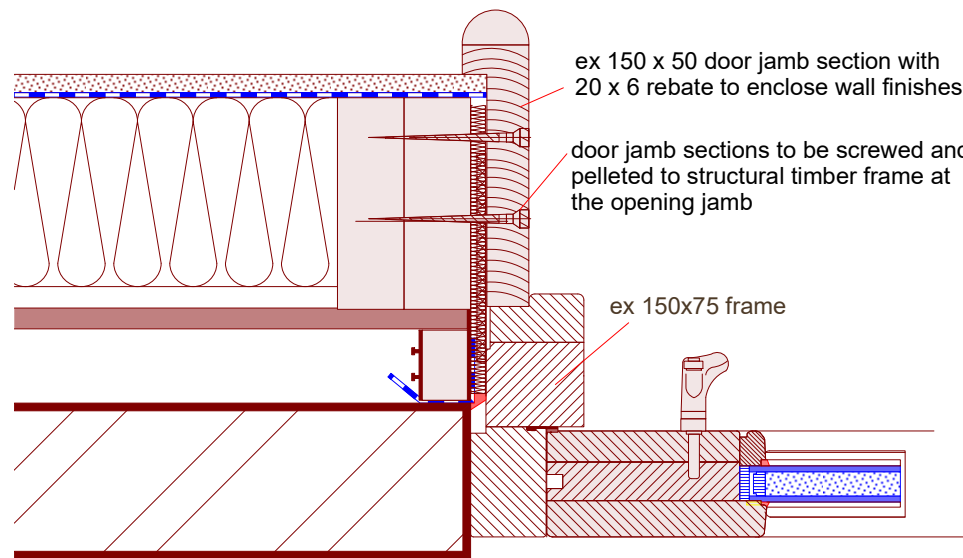

ex 150 x 50 door jamb section with 20 x 6 rebate to enclose wall finishes

door jamb sections to be screwed and pelleted to structural timber frame at the opening jamb

ex 150x75 frame

ex 175 x 50 door jamb section with 20 x 6 rebate to enclose wall finishes

component sizes of doors
 height (mm) 2040
 stiles (mm) ex 125 x 75
 bottom rail (mm) 180 x 75
 lower middle rail (mm) ex112 x 75
 upper middle rail (mm) ex112 x 75
 top rail (mm) ex 125 x 75

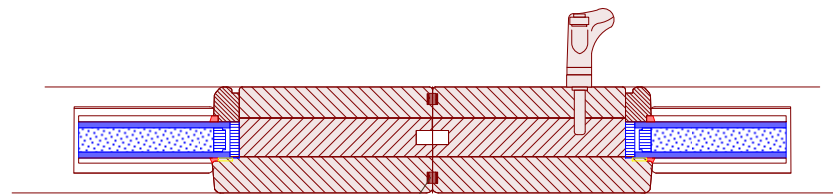

gasket sealing system to doors where closing onto frame and other doors

lining to door jambs to be the same as the lining to the window jambs and rebated into the window frames

gasket sealing system to doors where closing onto frame and other doors

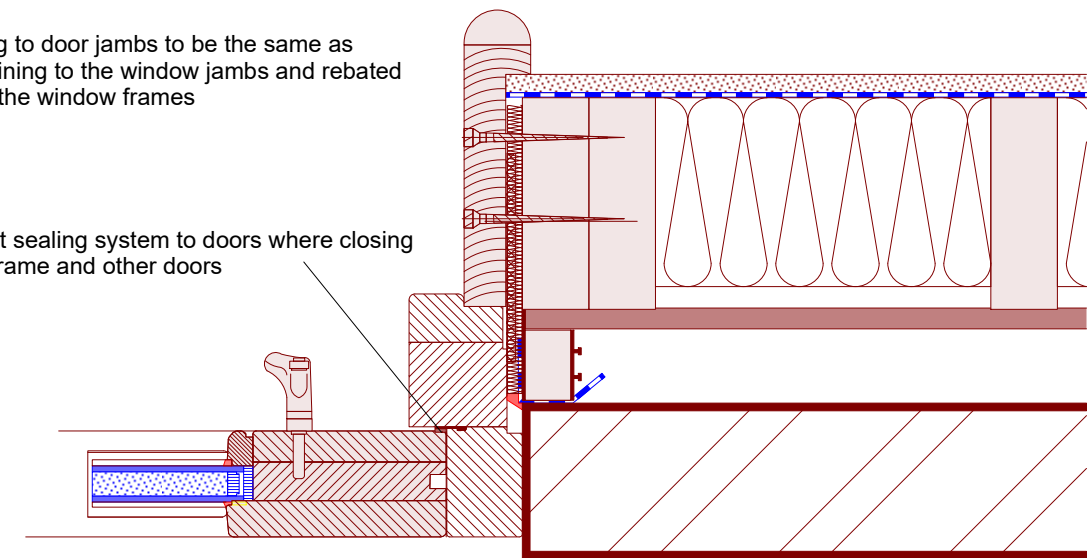

detail : external doors
 scale : 1 : 5 @ A3
 dwg. no : tcj2
 date : 08.12

John Blaymires 56 Pasture Lane
 Dipl. Arch (Leeds) RIBA Seamer
 Scarborough YO12 4QR

CLIENT ox pasture hall hotel
 PROJECT 2016 proposed spa complex and suites

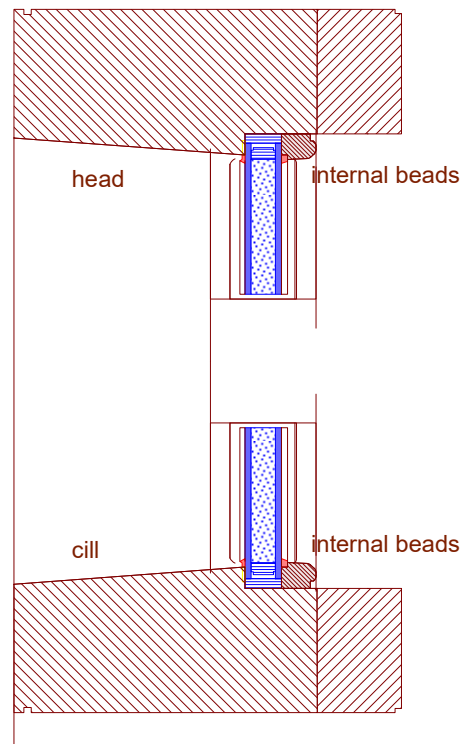

details of the cill and head to frame

WINDOWS AND DOORS AND POOL HALL GLAZING

All windows and doors to be high performance weather rated purpose made timber designed to the approval of the local planning authority
 (note: habitable rooms opening light size to achieve minimum 1/20 of floor area for rapid ventilation part of which should be 1.75m above floor level)
 All doors to have trickle vents fitted giving background ventilation of not less than 8000mm sq to habitable rooms and 4000mm sq to all other areas

Glazing to doors which is wholly or partially within 1500mm from the floor level to be safety glazing to a minimum Class C and marked accordingly to BS 6206
 Glazing adjacent to doors which is wholly or partially within 300mm of the edge of a door & which is also wholly or partially within 1500mm from the floor level to be safety glazing to a minimum Class C and marked accordingly to BS 6206
 Low level glazing other than glazing in doors and glazing adjacent to doors which is wholly or partially within 800mm from the floor level to be safety glazing to a minimum Class C and marked accordingly to BS 6206
 Note: escape windows to be provided to suit unobstructed openable area that is at least 0.33m² and at least 450mm high and 450mm wide (the route thro' may be at an angle rather than straight thro') the bottom of the openable area should be not more than 1100mm above the floor

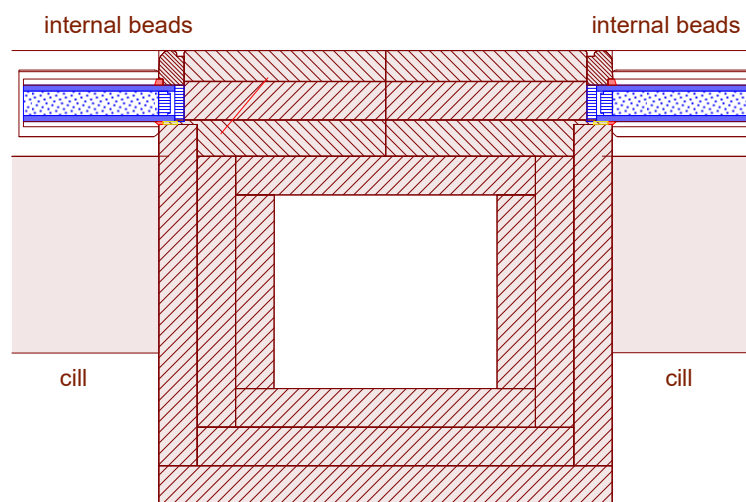

300x300 square vertical column

jamb sections to be screwed and pelleted to structural timber frame at the opening jamb
 lining to jambs to be the same as the lining to the window jambs and rebated into the window frames

gasket sealing system to doors where closing onto frame and other doors

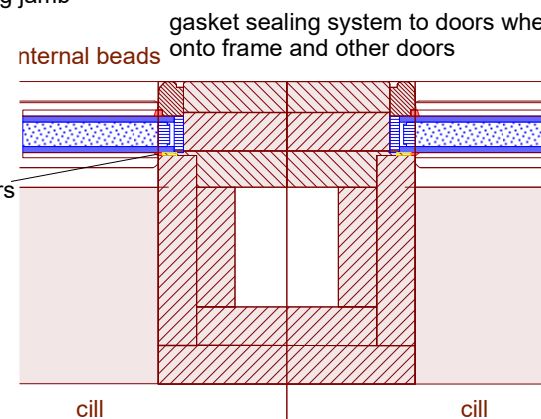

200x200 square vertical column

doors and frames constructed from triple laminated solid timber sections with espagnolette multipoint locking systems

Timber
 to be treated laminated hardwood and sourced from sustainable sources only and in compliance with the terms required by the British Woodworking Federation BWF Timber Window Accreditation TWA scheme
 All timber to comply with the requirements of BS EN 942 2007.

Preservation
 components to be subjected to preservative treatment by double vacuum pressure impregnation The preservative to be used must meet UK Building Regulations

Glass
 proposed double glazed units to be a 4:16:4 (24mm) argon gas filled unit with softcoat Saint Gobain Low-E glass on the inside leaf, giving a U value of 1.2 W/m²K. The type of edge spacer used within the unit to be warmedge type.
 A toughened/laminated glass is used where necessary to comply with the Building Regulations;

Operation and Ironmongery
 7 lever lock and espagnolette multiple locking mechanism

Ironmongery to be in brushed stainless steel finish

The windows are draught-sealed with gaskets.

WEATHERSHIELD AQUATECH WOODSTAIN - external
 DULUX TRADE PROTECTIVE WOODSHEEN - internal
 Surfaces must be sound, clean and dry before treating. if necessary strip back to bare wood.
 Remove and treat any mould, algae, lichen or moss with *Weathershield Multi-Surface Fungicidal Wash.
 Clean the rebates and any loose or open joints.
 Thoroughly rub down all surfaces in the direction of the grain to remove any grey, weathered wood and surface sheen from remaining coatings, and then dust off (refer to your COSHH Assessment).
 Prime all bare wood with 1 coat of ** Weathershield Aquatech Preservative Basecoat+ (BP) including any new or bare replacement beading. Excess basecoat should be wiped off surrounding paintwork.

Mix the ** Weathershield Aquatech Preservative Basecoat+ (BP) thoroughly by shaking the container. Pour out a sufficient amount of primer for the job into a suitable metal container. Do not use direct from the can or return any unused basecoat to the container. Do not thin.
 Fill any surface defects, open joints etc. Do not use linseed oil putty for glazing (or making good) with natural wood finishes, The normal finishing process is 2 coats of Weathershield Aquatech Woodstain.
 When treating timber that has been pressure impregnated with preservative ensure that the surface is completely dry. The use of silicone sealants can cause "cissing" of this product. Do not use on resinous wood or woodwork with a history of blistering. The maximum benefits of this system will only be realised when used as directed above on good quality timber that conforms to BS942: 2007 (or as amended), in conjunction with good component design.

NYMNPA
 09/05/2019

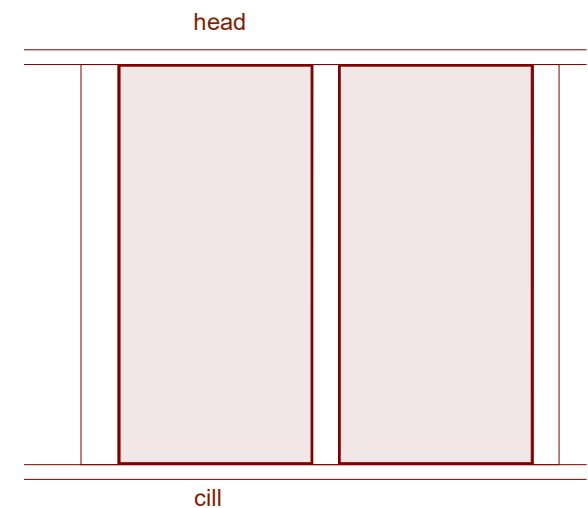

elevation of the cill and head to frame scale 1:100

detail : pool hall glazing
 scale : 1 : 5 @ A3
 dwg. no : tcj2
 date : 08.12

John Blaymires 56 Pasture Lane
 Dipl. Arch (Leeds) RIBA Seamer
 Scarborough YO12 4QR
 CLIENT ox pasture hall hotel
 PROJECT 2016 proposed spa complex and suites

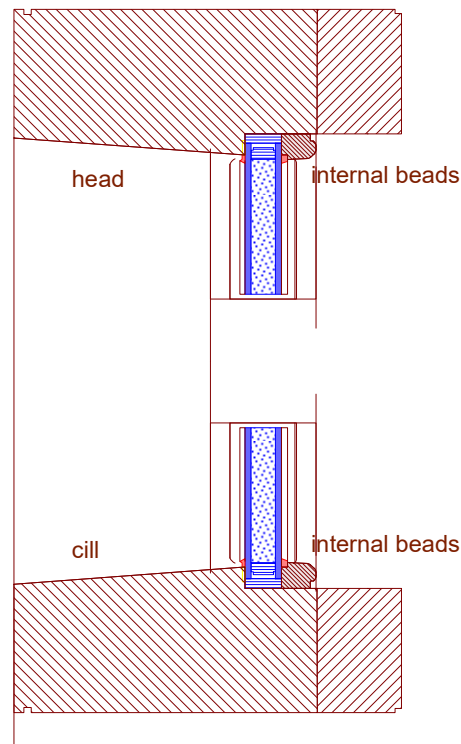

details of the cill and head to frame

WINDOWS AND DOORS AND POOL HALL GLAZING

All windows and doors to be high performance weather rated purpose made timber designed to the approval of the local planning authority
 (note: habitable rooms opening light size to achieve minimum 1/20 of floor area for rapid ventilation part of which should be 1.75m above floor level)
 All doors to have trickle vents fitted giving background ventilation of not less than 8000mm sq to habitable rooms and 4000mm sq to all other areas

Glazing to doors which is wholly or partially within 1500mm from the floor level to be safety glazing to a minimum Class C and marked accordingly to BS 6206
 Glazing adjacent to doors which is wholly or partially within 300mm of the edge of a door & which is also wholly or partially within 1500mm from the floor level to be safety glazing to a minimum Class C and marked accordingly to BS 6206
 Low level glazing other than glazing in doors and glazing adjacent to doors which is wholly or partially within 800mm from the floor level to be safety glazing to a minimum Class C and marked accordingly to BS 6206
 Note: escape windows to be provided to suit unobstructed openable area that is at least 0.33m² and at least 450mm high and 450mm wide (the route thro' may be at an angle rather than straight thro') the bottom of the openable area should be not more than 1100mm above the floor

gasket sealing system to doors where closing onto frame and other doors

doors and frames constructed from triple laminated solid timber sections with espagnolette multipoint locking systems

Timber
 to be treated laminated hardwood and sourced from sustainable sources only and in compliance with the terms required by the British Woodworking Federation BWF Timber Window Accreditation TWA scheme
 All timber to comply with the requirements of BS EN 942 2007.

Preservation
 components to be subjected to preservative treatment by double vacuum pressure impregnation The preservative to be used must meet UK Building Regulations

Glass
 proposed double glazed units to be a 4:16:4 (24mm) argon gas filled unit with softcoat Saint Gobain Low-E glass on the inside leaf, giving a U value of 1.2 W/m²K. The type of edge spacer used within the unit to be warmedge type.
 A toughened/laminated glass is used where necessary to comply with the Building Regulations;

Operation and Ironmongery
 7 lever lock and espagnolette multiple locking mechanism

Ironmongery to be in brushed stainless steel finish

The windows are draught-sealed with gaskets.

WEATHERSHIELD AQUATECH WOODSTAIN - external
 DULUX TRADE PROTECTIVE WOODSHEEN - internal
 Surfaces must be sound, clean and dry before treating. if necessary strip back to bare wood.
 Remove and treat any mould, algae, lichen or moss with *Weathershield Multi-Surface Fungicidal Wash.
 Clean the rebates and any loose or open joints.
 Thoroughly rub down all surfaces in the direction of the grain to remove any grey, weathered wood and surface sheen from remaining coatings, and then dust off (refer to your COSHH Assessment).
 Prime all bare wood with 1 coat of ** Weathershield Aquatech Preservative Basecoat+ (BP) including any new or bare replacement beading. Excess basecoat should be wiped off surrounding paintwork.

Mix the ** Weathershield Aquatech Preservative Basecoat+ (BP) thoroughly by shaking the container. Pour out a sufficient amount of primer for the job into a suitable metal container. Do not use direct from the can or return any unused basecoat to the container. Do not thin.
 Fill any surface defects, open joints etc. Do not use linseed oil putty for glazing (or making good) with natural wood finishes, The normal finishing process is 2 coats of Weathershield Aquatech Woodstain.
 When treating timber that has been pressure impregnated with preservative ensure that the surface is completely dry. The use of silicone sealants can cause "cissing" of this product. Do not use on resinous wood or woodwork with a history of blistering. The maximum benefits of this system will only be realised when used as directed above on good quality timber that conforms to BS942: 2007 (or as amended), in conjunction with good component design.

NYMNPA
 09/05/2019

lining to jambs to be the same as the lining to the window jambs and rebated into the window frames

jamb sections to be screwed and pelleted to structural timber frame at the opening jamb

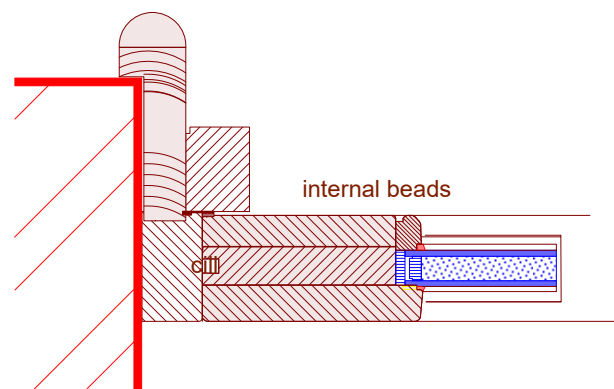

300x300 square vertical column

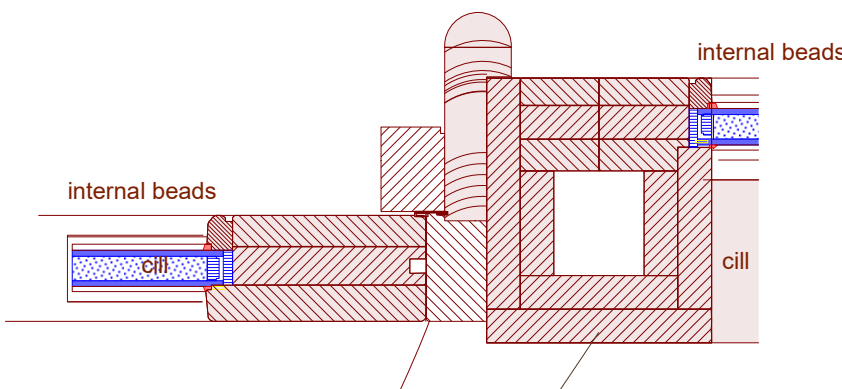

170x170 square vertical column

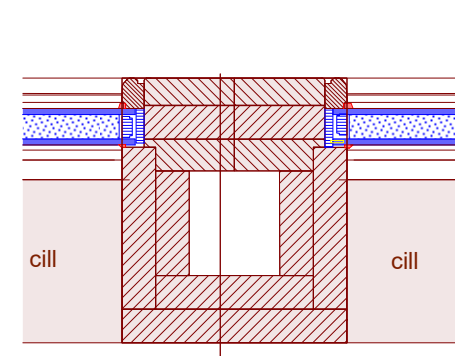

gasket sealing system to doors where closing onto frame and other doors

detail : relaxation room glazing
 scale : 1 : 5 @ A3
 dwg. no : tcj2
 date : 08.12

John Blaymires 56 Pasture Lane
 Seamer
 Scarborough YO12 4QR
 Dipl. Arch (Leeds) RIBA
 CLIENT ox pasture hall hotel
 PROJECT 2016 proposed spa complex and suites

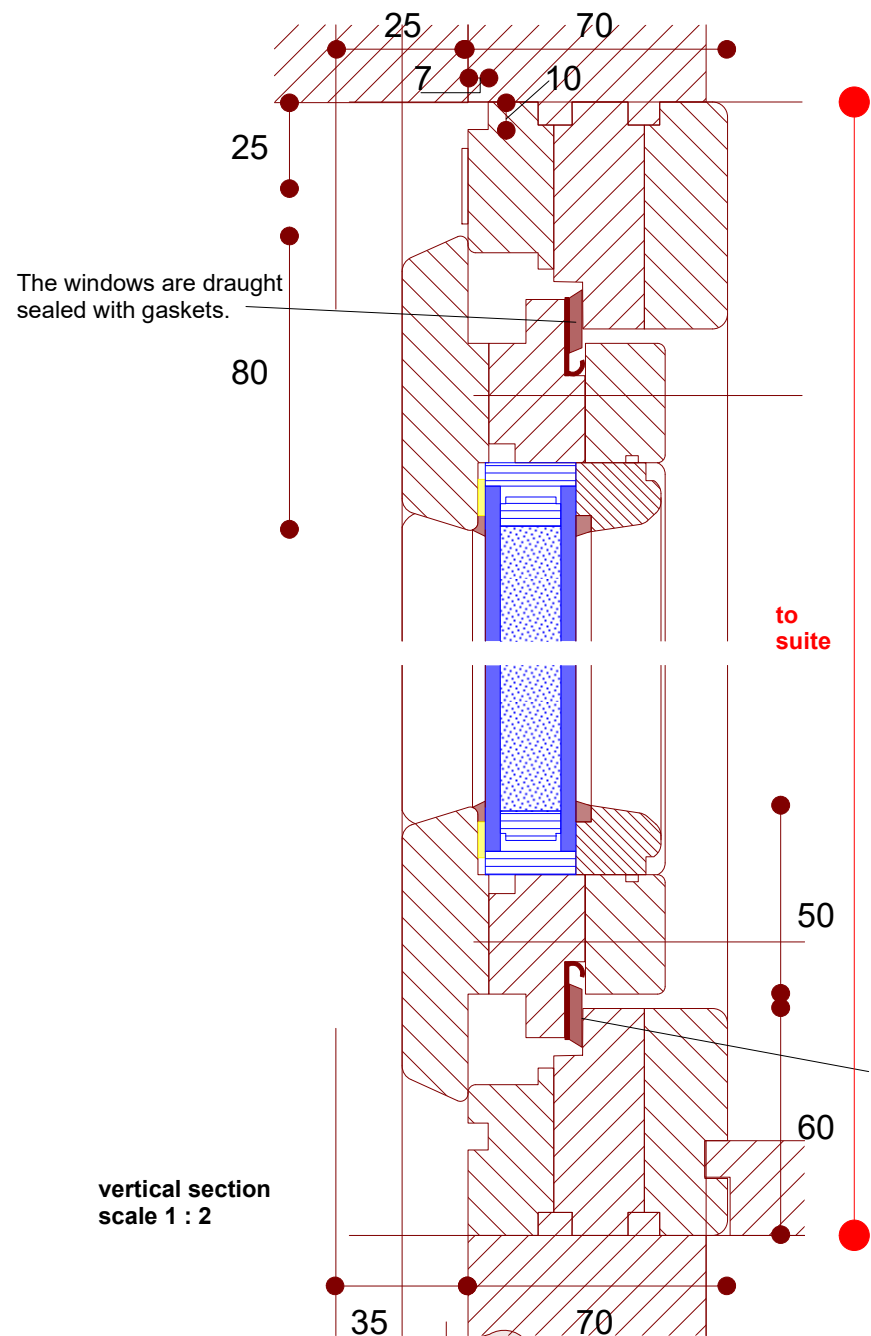

vertical section
scale 1 : 2

Timber
to be treated laminated hardwood and sourced from sustainable sources only and in compliance with the terms required by the British Woodworking Federation BWF Timber Window Accreditation TWA scheme
All timber to comply with the requirements of BS EN 942 2007.

Preservation
components to be subjected to preservative treatment by double vacuum pressure impregnation The preservative to be used must meet UK Building Regulations

Glass
proposed double glazed units to be a 4:16:4 (24mm) argon gas filled unit with softcoat Saint Gobain Low-E glass on the inside leaf, giving a U value of 1.2 W/m2K. The type of edge spacer used within the unit to be warmedge type.
A toughened/laminated glass is used where necessary to comply with the Building Regulations;

Operation and Ironmongery
Side Hung operation - a casement stay and fastener with a lockable handle for an increased security
Ironmongery to be brushed stainless steel finish

The windows are draught-sealed with gaskets.

The windows are draught-sealed with gaskets.

proposed double glazed units to be a 4:16:4 (24mm) argon gas filled unit with softcoat low emissivity (Low E) glass on the inside leaf, giving a glass U value of 1.2. The type of edge spacer used within the unit to be warmedge spacer bars.

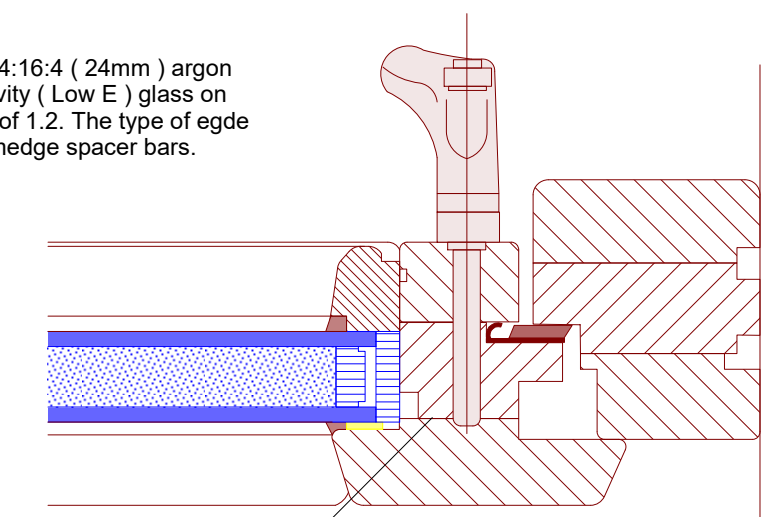

horizontal section
scale 1 : 2

The windows are draught sealed with gaskets.

The windows are draught sealed with gaskets.

The windows are draught sealed with gaskets.

to suite



friction hinge - stainless steel

WEATHERSHIELD AQUATECH WOODSTAIN - external
DULUX TRADE PROTECTIVE WOODSHEEN - internal
Surfaces must be sound, clean and dry before treating. if necessary strip back to bare wood.
Remove and treat any mould, algae, lichen or moss with *Weathershield Multi-Surface Fungicidal Wash.
Clean the rebates and any loose or open joints.
Thoroughly rub down all surfaces in the direction of the grain to remove any grey, weathered wood and surface sheen from remaining coatings, and then dust off (refer to your COSHH Assessment).
Prime all bare wood with 1 coat of ** Weathershield Aquatech Preservative Basecoat+ (BP) including any new or bare replacement beading. Excess basecoat should be wiped off surrounding paintwork.

Mix the ** Weathershield Aquatech Preservative Basecoat+ (BP) thoroughly by shaking the container. Pour out a sufficient amount of primer for the job into a suitable metal container. Do not use direct from the can or return any unused basecoat to the container. Do not thin.
Fill any surface defects, open joints etc. Do not use linseed oil putty for glazing (or making good) with natural wood finishes, The normal finishing process is 2 coats of Weathershield Aquatech Woodstain.
When treating timber that has been pressure impregnated with preservative ensure that the surface is completely dry.
The use of silicone sealants can cause "cissing" of this product. Do not use on resinous wood or woodwork with a history of blistering. The maximum benefits of this system will only be realised when used as directed above on good quality timber that conforms to BS942: 2007 (or as amended), in conjunction with good component design.

detail : casement window detail
scale : 1 : 2 @ A3

John Blaymires 56 Pasture Lane
Seamer
Dipl. Arch (Leeds) RIBA Scarborough YO12 4QR

CLIENT ox pasture hall hotel
PROJECT 2016 proposed spa complex and suites

TREATMENT OF THE VERTICAL BOARDING
WEATHERSHIELD AQUATECH WOODSTAIN - external
 Surfaces must be sound, clean and dry before treating.
 if necessary strip back to bare wood.
 Remove and treat any mould, algae, lichen or moss with
 *Weathershield Multi-Surface Fungicidal Wash.
 Clean the rebates and any loose or open joints.
 Thoroughly rub down all surfaces in the direction of the grain to
 remove any grey, weathered wood and surface sheen from
 remaining coatings, and then dust off (refer to your COSHH
 Assessment).
 Prime all bare wood with 1 coat of ** Weathershield Aquatech
 Preservative Basecoat+ (BP) including any new or bare
 replacement beading. Excess basecoat should be wiped off
 surrounding paintwork.

Mix the ** Weathershield Aquatech Preservative Basecoat+ (BP)
 thoroughly by shaking the container. Pour out a sufficient
 amount of primer for the job into a suitable metal container. Do not use
 direct from the can or return any unused basecoat to
 the container. Do not thin.
 Fill any surface defects, open joints etc. Do not use linseed oil putty for
 glazing (or making good) with natural wood finishes.
 The normal finishing process is 2 coats of Weathershield Aquatech
 Woodstain.
 When treating timber that has been pressure impregnated with
 preservative ensure that the surface is completely dry.
 The use of silicone sealants can cause "cissing" of this product. Do not
 use on resinous wood or woodwork with a history of blistering. The
 maximum benefits of this system will only be realised when used as
 directed above on good quality timber that conforms to BS942: 2007
 (or as amended), in conjunction with good component design.

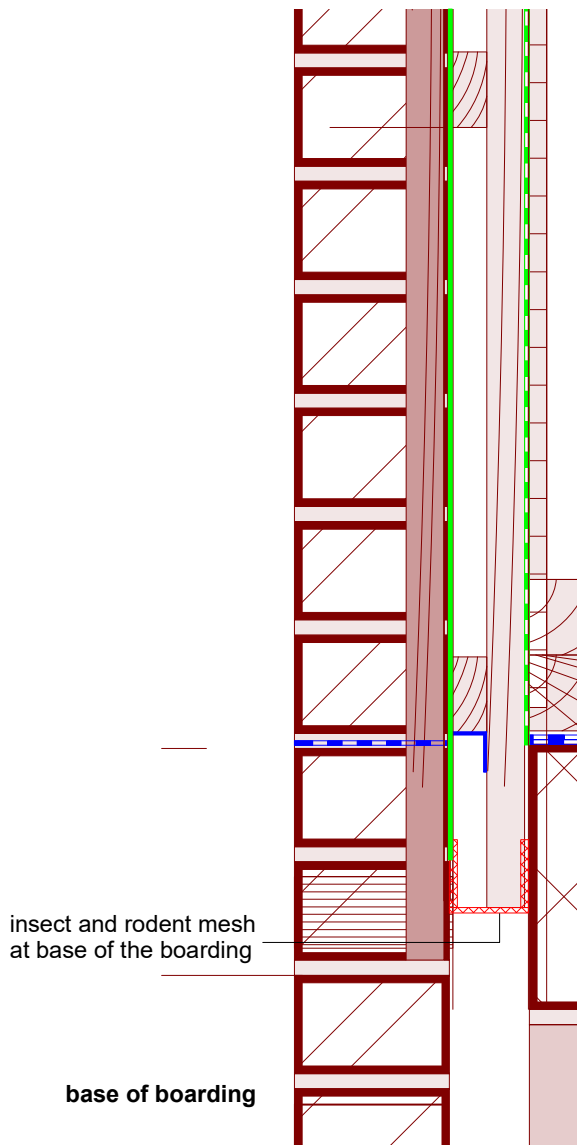

John Blaymires	56 Pasture Lane
	Seamer
Dipl. Arch (Leeds) RIBA	Scarborough YO12 4QR
CLIENT ox pasture hall hotel	
PROJECT 2016 proposed spa complex and suites	

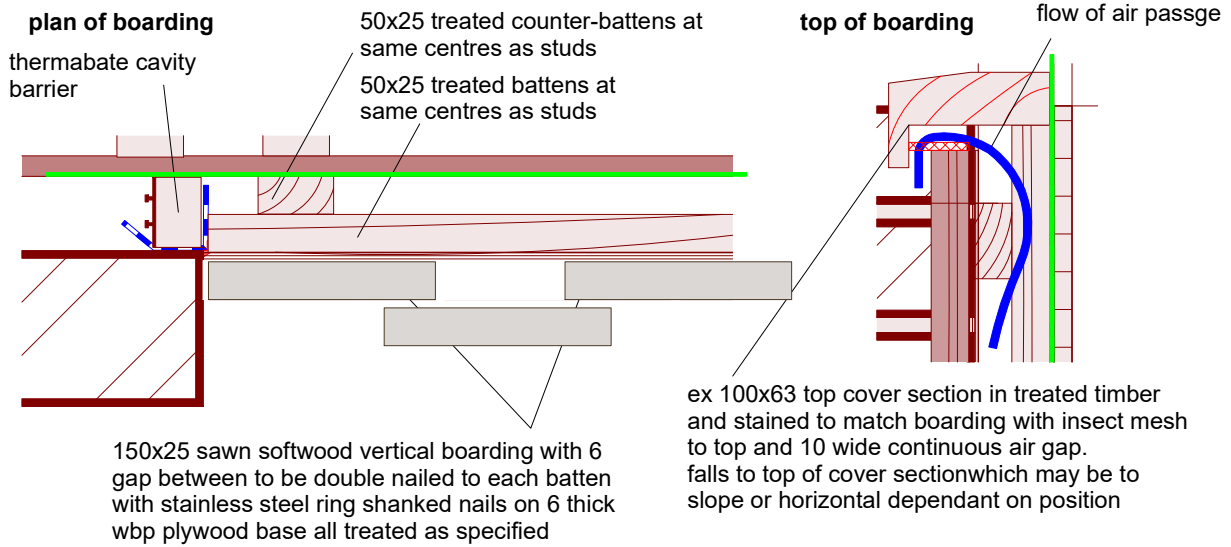

detail : vertical timber boarding
 scale : 1 : 5 @ A4

doors and frames constructed from triple laminated solid timber sections with espagnolette multipoint locking systems

Timber
to be treated laminated hardwood and sourced from sustainable sources only and in compliance with the terms required by the British Woodworking Federation BWF Timber Window Accreditation TWA scheme
All timber to comply with the requirements of BS EN 942 2007.

Preservation
components to be subjected to preservative treatment by double vacuum pressure impregnation The preservative to be used must meet UK Building Regulations

Glass
proposed double glazed units to be a 4:16:4 (24mm) argon gas filled unit with softcoat Saint Gobain Low-E glass on the inside leaf, giving a U value of 1.2 W/m2K. The type of edge spacer used within the unit to be warmedge type.
A toughened/laminated glass is used where necessary to comply with the Building Regulations;

Operation and Ironmongery
7 lever lock and espagnolette multiple locking mechanism

Ironmongery to be in brushed stainless steel finish

The windows are draught-sealed with gaskets.

WEATHERSHIELD AQUATECH WOODSTAIN - external
DULUX TRADE PROTECTIVE WOODSHEEN - internal
Surfaces must be sound, clean and dry before treating. if necessary strip back to bare wood.
Remove and treat any mould, algae, lichen or moss with *Weathershield Multi-Surface Fungicidal Wash.
Clean the rebates and any loose or open joints.
Thoroughly rub down all surfaces in the direction of the grain to remove any grey, weathered wood and surface sheen from remaining coatings, and then dust off (refer to your COSHH Assessment).
Prime all bare wood with 1 coat of ** Weathershield Aquatech Preservative Basecoat+ (BP) including any new or bare replacement beading. Excess basecoat should be wiped off surrounding paintwork.

Mix the ** Weathershield Aquatech Preservative Basecoat+ (BP) thoroughly by shaking the container. Pour out a sufficient amount of primer for the job into a suitable metal container. Do not use direct from the can or return any unused basecoat to the container. Do not thin.
Fill any surface defects, open joints etc. Do not use linseed oil putty for glazing (or making good) with natural wood finishes, The normal finishing process is 2 coats of Weathershield Aquatech Woodstain.
When treating timber that has been pressure impregnated with preservative ensure that the surface is completely dry. The use of silicone sealants can cause "cissing" of this product. Do not use on resinous wood or woodwork with a history of blistering. The maximum benefits of this system will only be realised when used as directed above on good quality timber that conforms to BS942: 2007 (or as amended), in conjunction with good component design.

WINDOWS AND DOORS AND POOL HALL GLAZING

All windows and doors to be high performance weather rated purpose made timber designed to the approval of the local planning authority
(note: habitable rooms opening light size to achieve minimum 1/20 of floor area for rapid ventilation part of which should be 1.75m above floor level)
All doors to have trickle vents fitted giving background ventilation of not less than 8000mm sq to habitable rooms and 4000mm sq to all other areas

Glazing to doors which is wholly or partially within 1500mm from the floor level to be safety glazing to a minimum Class C and marked accordingly to BS 6206
Glazing adjacent to doors which is wholly or partially within 300mm of the edge of a door & which is also wholly or partially within 1500mm from the floor level to be safety glazing to a minimum Class C and marked accordingly to BS 6206
Low level glazing other than glazing in doors and glazing adjacent to doors which is wholly or partially within 800mm from the floor level to be safety glazing to a minimum Class C and marked accordingly to BS 6206
Note: escape windows to be provided to suit unobstructed openable area that is at least 0.33m² and at least 450mm high and 450mm wide (the route thro' may be at an angle rather than straight thro') the bottom of the openable area should be not more than 1100mm above the floor

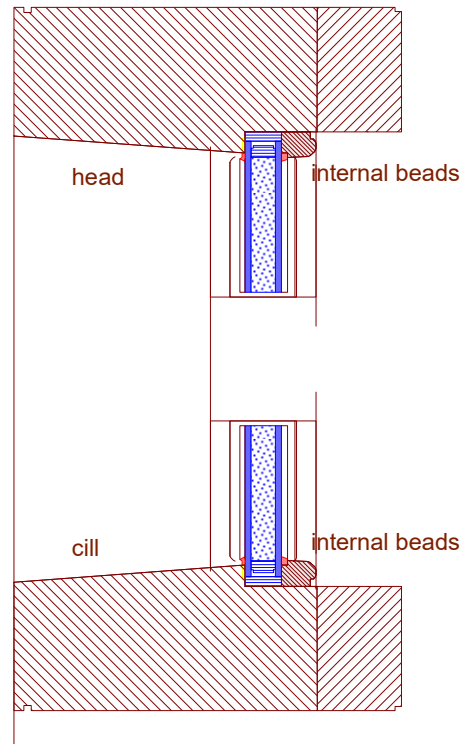

details of the cill and head to frame

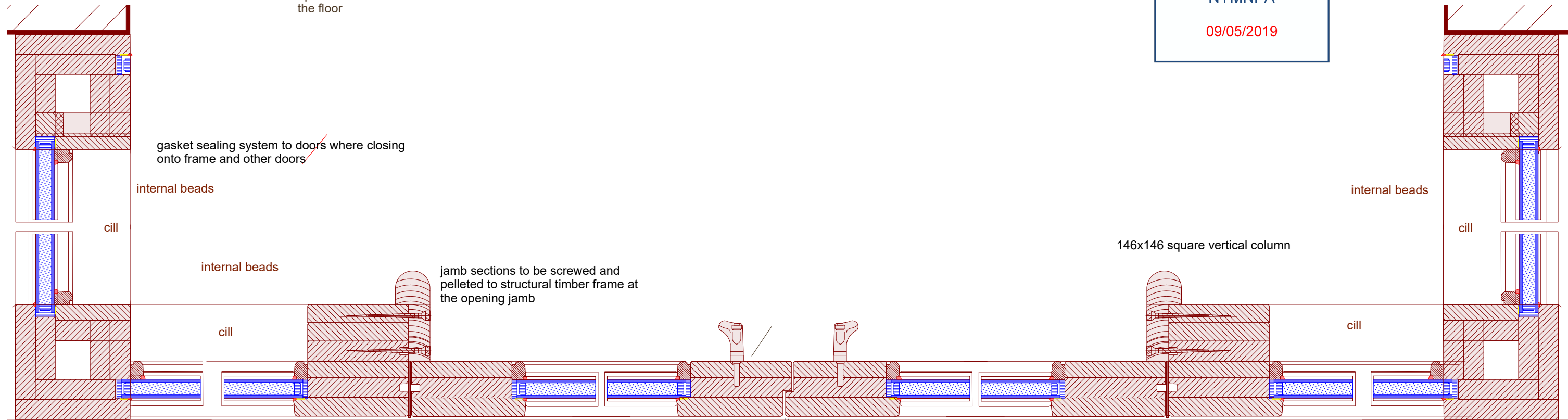

NYMNPA
09/05/2019

146x146 square vertical column 146x146 square vertical column

detail : entrance porch
scale : 1 : 5 @ A3
dwg. no : tcj2
date : 08.12

John Blaymires	56 Pasture Lane Seamer Scarborough YO12 4QR
Dipl. Arch (Leeds) RIBA	
CLIENT ox pasture hall hotel PROJECT 2016 proposed spa complex and suites	