

NYMNPA

25/11/2019

From: J RICHARDSON
Sent: 24 November 2019 17:07
To: Megan O'Mara
Subject: Re: NYM/2019/0280/FL

Hi Megan,

Hope you are well.

Apologies again for lack of response and failing to get the required drawings to you as indicated below.

Unfortunately when they arrived they were just the same as those already submitted.

I have finally managed to find someone willing and able to assist.

Please find attached cross sectional drawings for the proposed window replacement. I trust they will meet your requirements and I look forward to hearing from you in due course.

Regards
Sandra

Mrs Sandra Richardson

On Tuesday, October 15, 2019, 10:00:27 AM GMT+1, Jim

wrote:

Hi Megan,

Please accept my apologies for the lack of progress to date. We are aiming to have the required drawings to you by the end of the week.

Regards
Sandra Richardson

On 29 Aug 2019, at 12:36, Megan O'Mara <m.omara@northyorkmoors.org.uk> wrote:

Dear Sandra

Is there any progress on the completion of the constructional drawings?

Kind regards

Megan

Megan O'Mara

Planning, Development Management

North York Moors National Park Authority

The Old Vicarage, Bondgate, Helmsley, YORK, YO62 5BP

t: 01439 772700

e: planning@northyorkmoors.org.uk

w: www.northyorkmoors.org.uk

Normal Working Hours:

Mon to Fri - 9:00am to 5pm

From: Jim [
Sent: 12 August 2019 16:57
To: Megan O'Mara
Subject: Re: NYM/2019/0280/FL

Hi Megan,

Apologies for not replying sooner, I am on holiday now until Mon 19th August.

I am currently having difficulty securing the cross sectional drawings required from the companies I received quotes from.

I will follow up with them on my return.

Thanks

Regards

Mrs Sandra Richardson

On 8 Aug 2019, at 09:27, Megan O'Mara <m.omara@northyorkmoors.org.uk> wrote:

Dear Mrs Richardson

As mentioned by Harriet below, I have now taken on this application on her departure from the National Park.

In response to the Authority's Building Conservation team's comments, I request that constructional drawings (including cross sections) are submitted to the Authority. The drawings must relate specifically to those being installed at the property – the joiner will be able to provide these for you.

If you have any queries regarding the above request, please do not hesitate to contact me to discuss this further.

Kind regards

Megan

Megan O'Mara

Planning, Development Management

North York Moors National Park Authority

The Old Vicarage, Bondgate, Helmsley, YORK, YO62 5BP

t: 01439 772700

e: planning@northyorkmoors.org.uk

w: www.northyorkmoors.org.uk

Normal Working Hours:

Mon to Fri - 9:00am to 5pm

From: Harriet Frank
Sent: 07 August 2019 10:57
To: Jim
Cc: Maria Calderon; Megan O'Mara
Subject: RE: NYM/2019/0280/FL

Dear Mrs Richardson

We require clarity on a few points surrounding the replacement windows therefore I would be grateful if you could get into contact with either Maria Calderon or Megan O'Mara within the planning department to discuss the application further. Our number is 01439 772700.

This planning application has now been reallocated to Megan who will be the planning officer dealing with the application from heron in, as it is my last day at the National Park today. I wish you luck with the application and hope you are able to get the outstanding issues resolved shortly.

Kind regards

Harriet

From: Jim
Sent: 07 August 2019 08:30
To: Harriet Frank
Subject: Re: NYM/2019/0280/FL

Hi Harriet,

Please find attached all information regarding window structure and design the manufacturer / supplier has supplied in addition to the drawings already submitted.

With regard to opening, we will adopt your teams preferred style.

Look forward to hearing from you in due course.

Regards

Mrs Sandra Richardson

<119080809271702649.jpg> [<119080809271702849.png>](#)

CONFIDENTIALITY: The contents of this message are the views of the author, not necessarily the views of the North York Moors National Park Authority. This is a private message intended for the named addressee(s) only. Its contents may be confidential.

If you have received this message in error please reply to say so and then delete the message. Any use, copying, disclosure or distribution by anyone other than the addressee is forbidden.

www.northyorkmoors.org.uk

This email has been scanned for email related threats and delivered safely by Mimecast.

For more information please visit <http://www.mimecast.com>

Bedroom 1 window (upper front left)

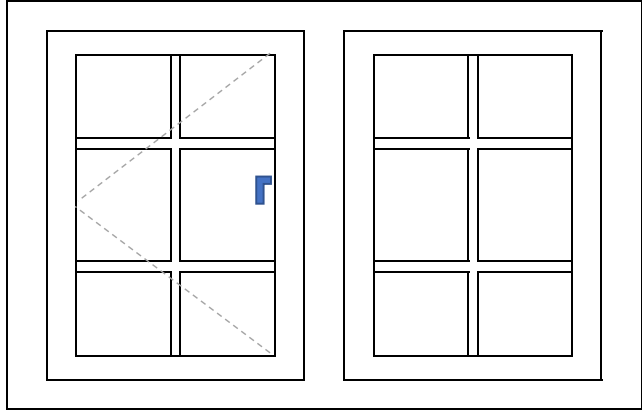

Bedroom 2 window cross sectional view

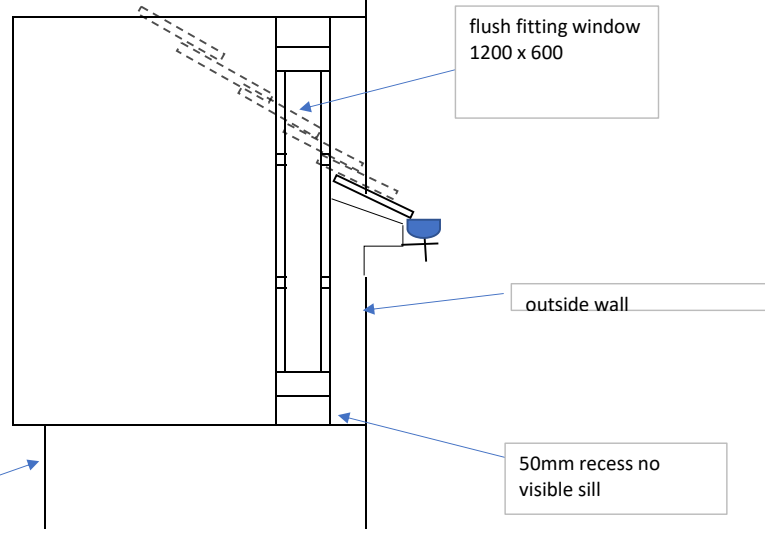

Bedroom 2 window (upper front right)

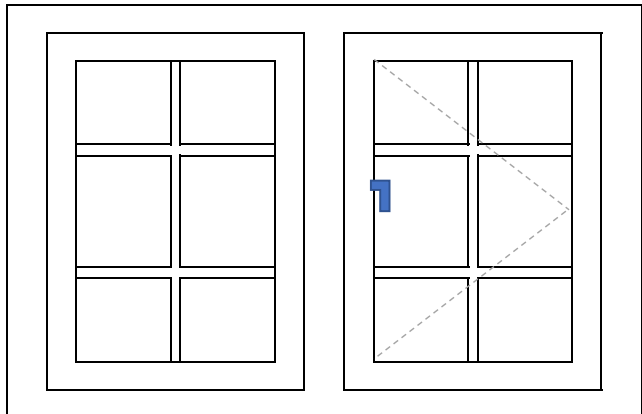

Bedroom 2 window cross sectional view

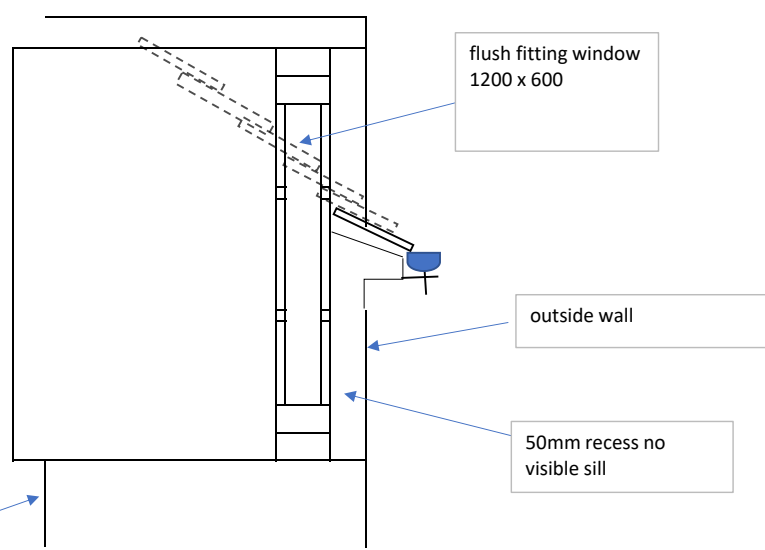

Kitchen window (lower front left)

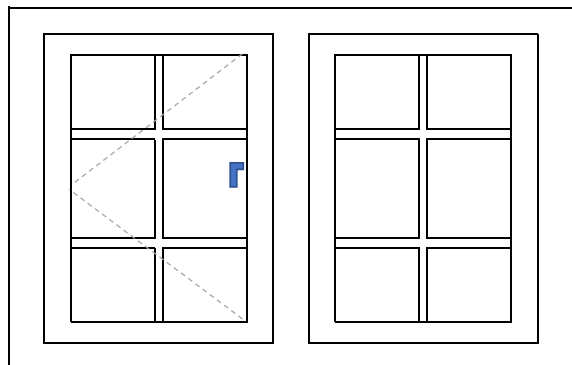

Kitchen window cross sectional view

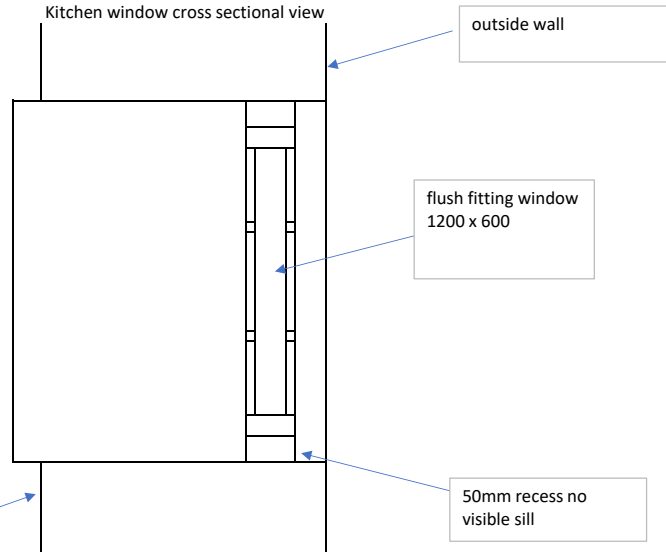

inner property wall

Lounge window (lower front right)

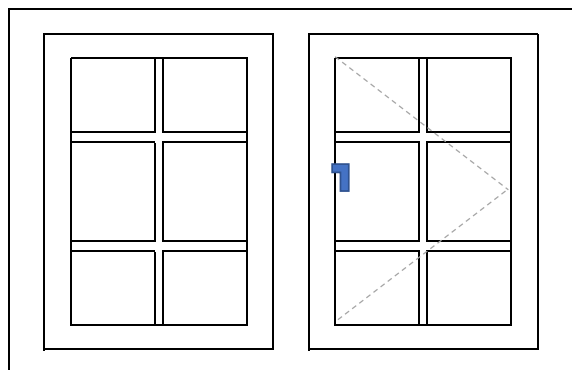

Lounge window cross sectional view

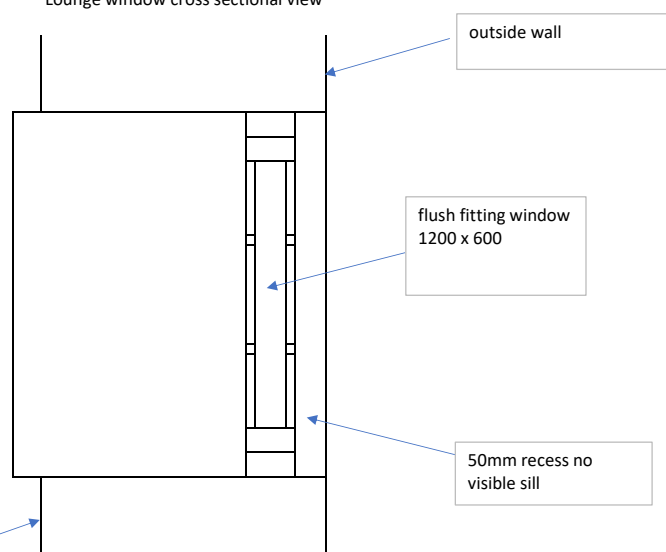

inner property wall