

Application Site Location Plan – Whitby Holiday Park, Whitby, North Yorkshire YO22 4JX.

Client :- Mr Peter Brewer, Normanhurst Enterprises Ltd, 9 Burscough Street, Ormskirk Lancashire. L39 2EG.

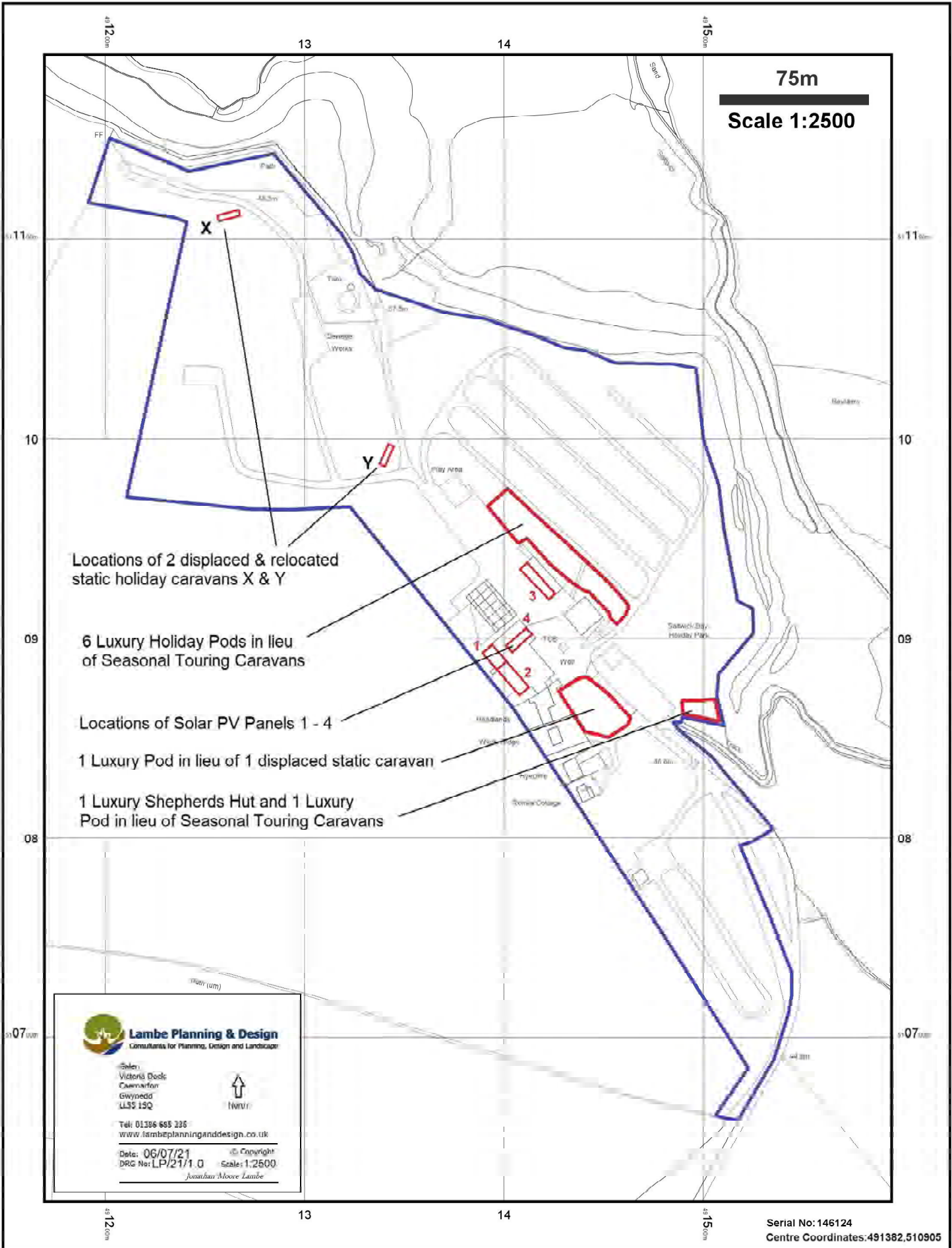

© Crown copyright and database rights 2018 Ordnance Survey 100048957.
The representation of road, track or path is no evidence of a boundary or right of way. The representation of features as lines is no evidence of a property boundary.





NYMNP
20/07/2021

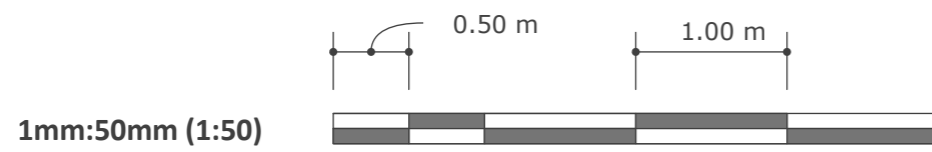
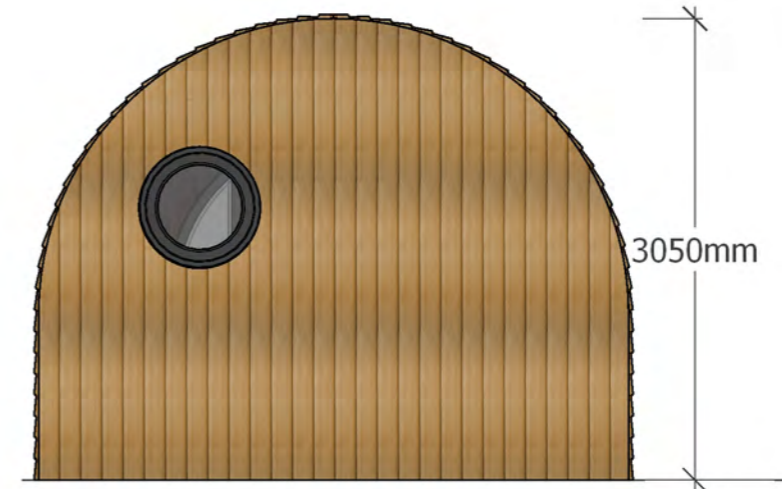
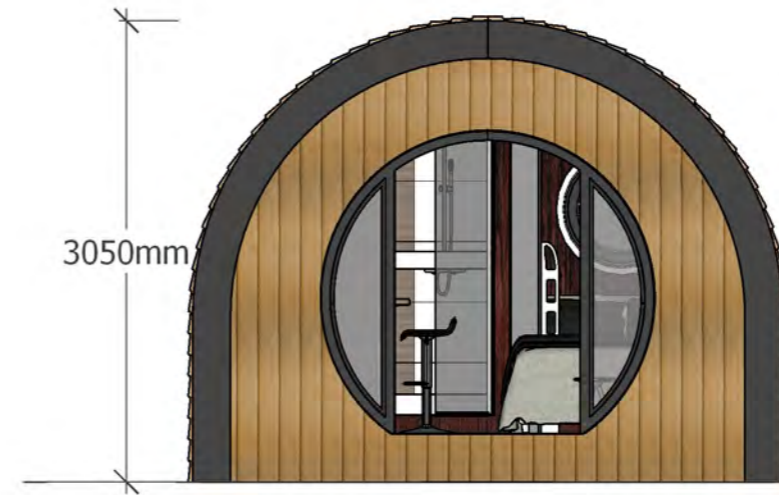
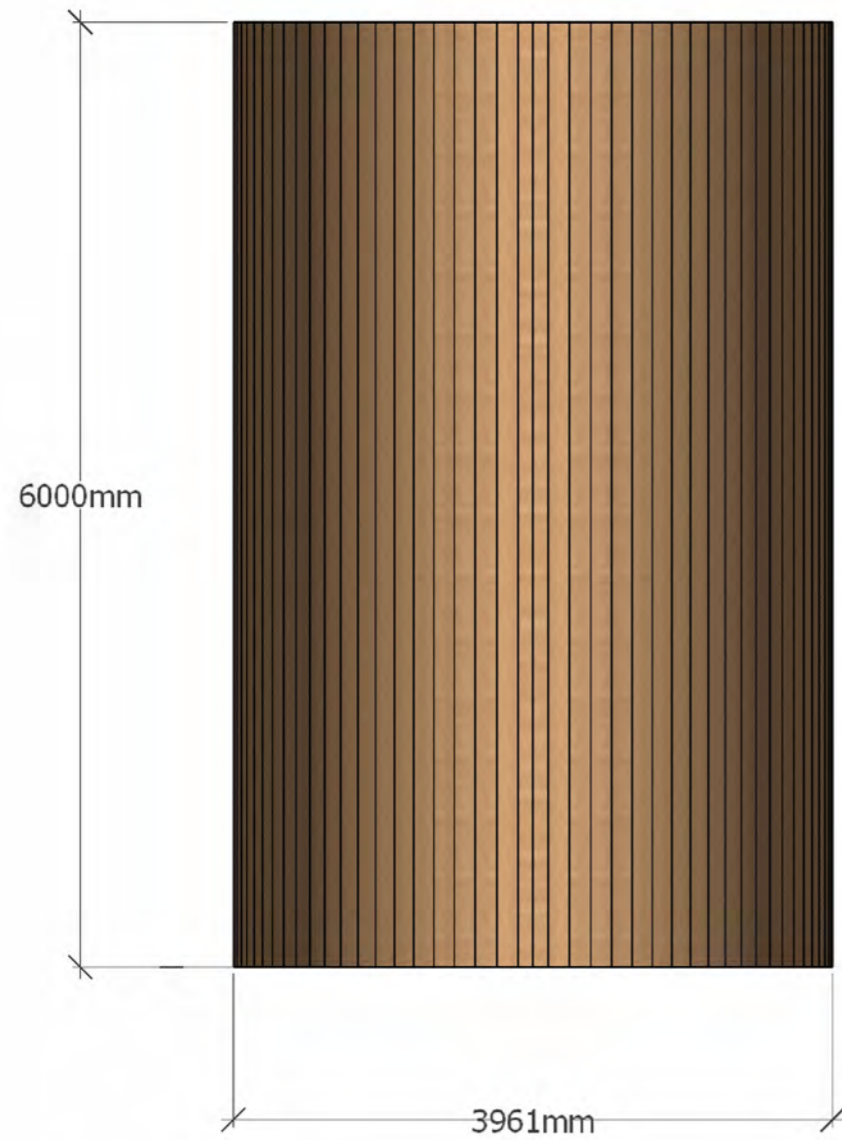

JAMIE LEWIS



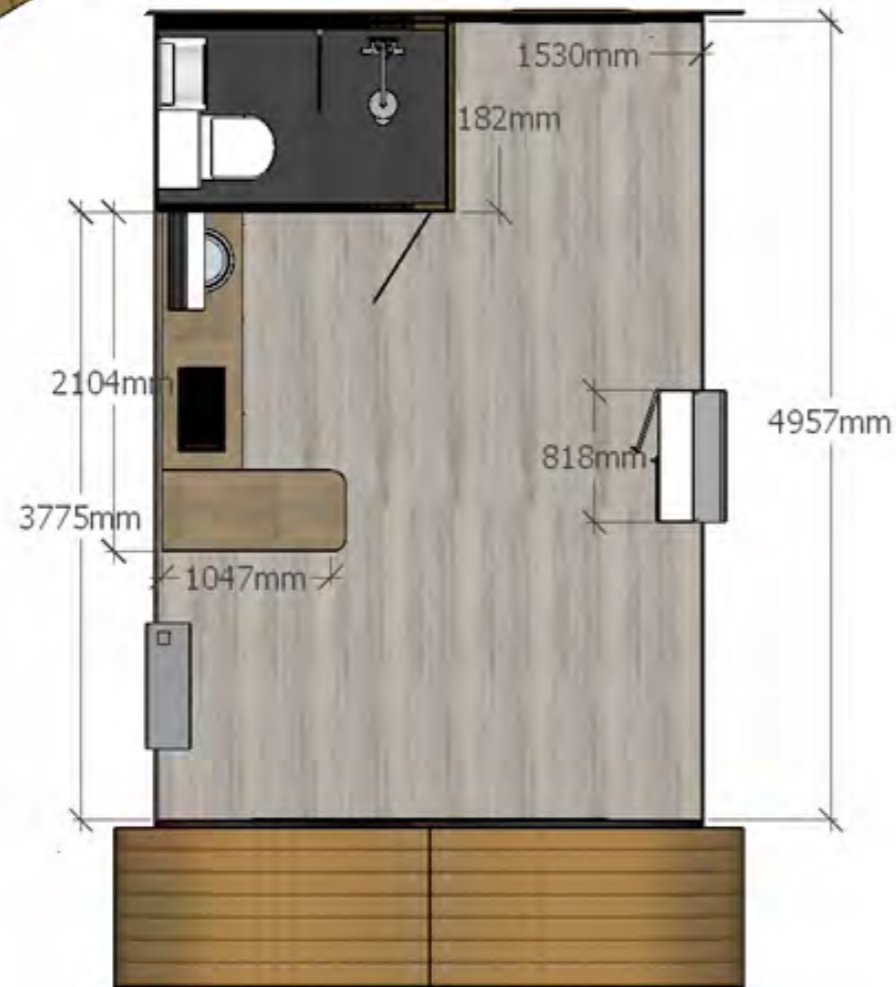
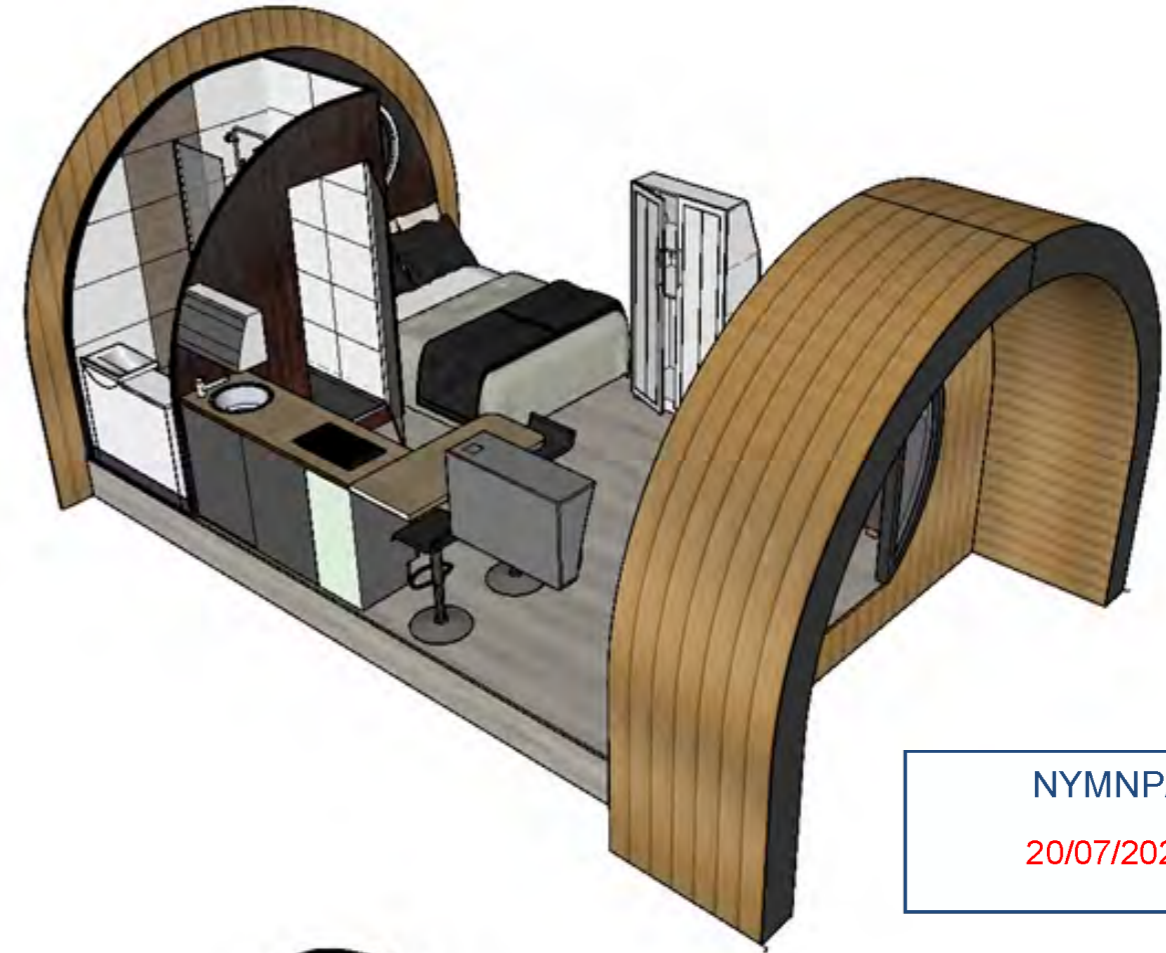
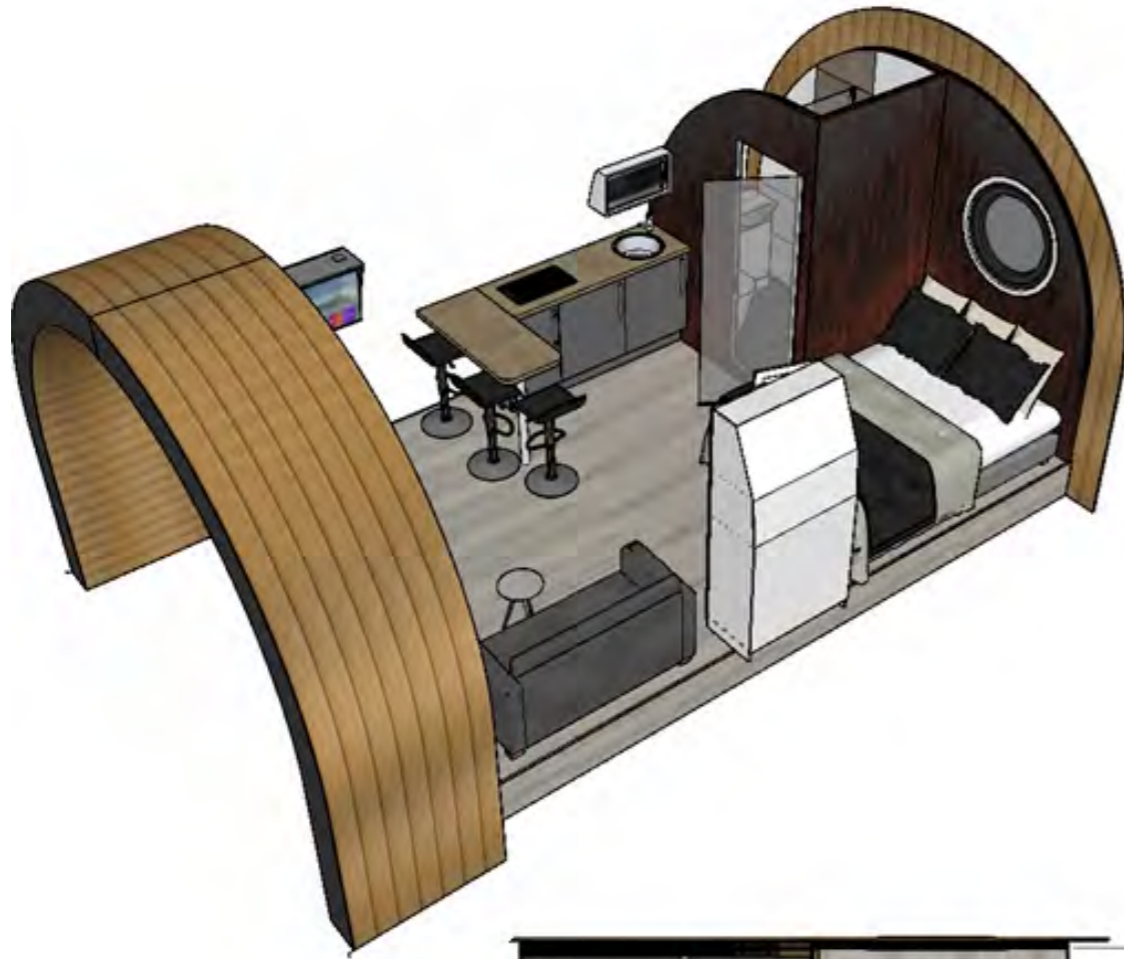

NYMNPA
20/07/2021

JAMIE LEWIS

Preseli extras applied to this drawing consist of the following below..

- large wet room
- 32" smart tv and pocket kit
- microwave plus pocket
- large kitchen pack
- large built in wardrobe

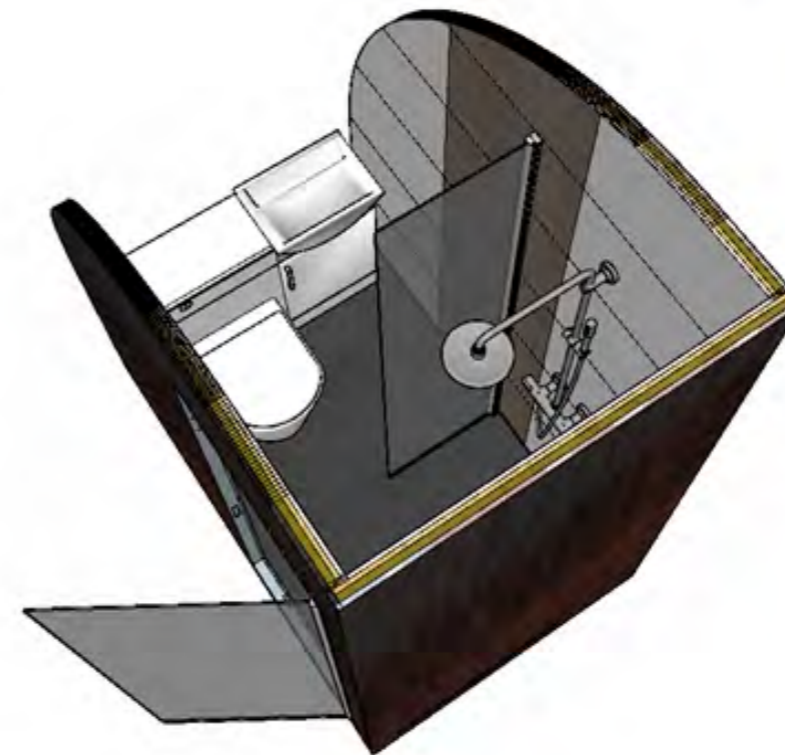

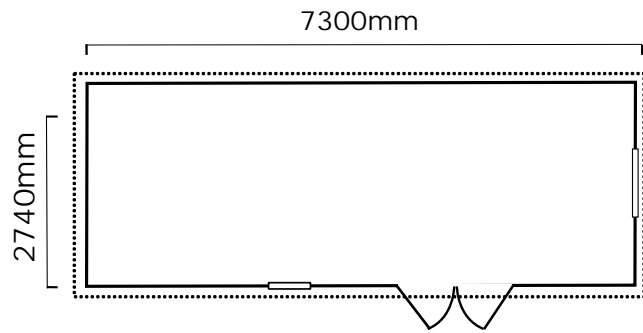

Plan View

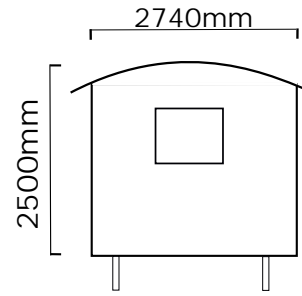

Right Elevation

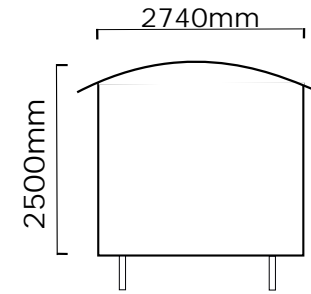

Left Elevation

NYMNPA
 20/07/2021

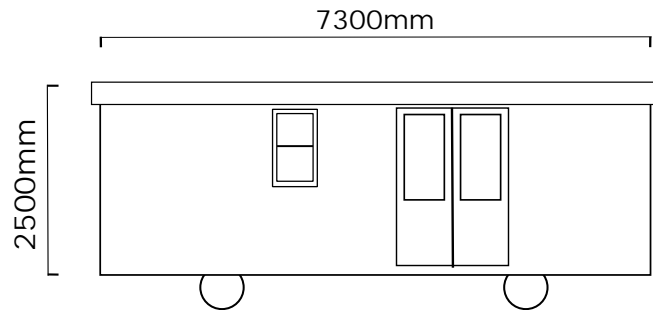

Front Elevation

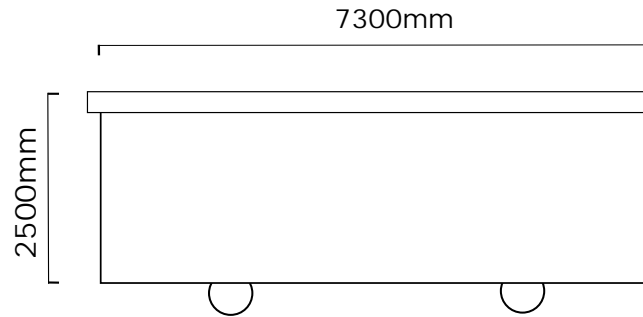

Rear Elevation

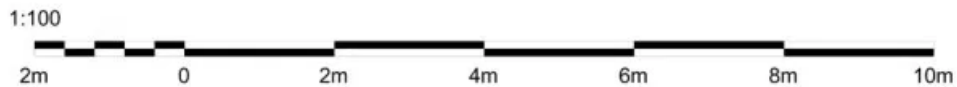

 Bespoke Garden Offices & Studios

Description: Timber Shepherds Hut Building on Wheels

Scale: 1:100

Drawn by: Ben Wong

Date: 26.09.2017

Exterior finishes

Walls: Timber feather edge cladding
 Roof: Corrugates steel sheeting
 Joinery: Painted timber with double glazed panes
 Wheels/Chassis: Cast iron painted black