

Amendments/Additional Information

- Amended layout of buildings/outside areas
- Additional background information
- Amended design
- Revised access arrangements
- Change of description of proposed development
- Change in site boundaries
- Other (as specified below)

Wendy Strangeway

From: Robert Harrison & Sons
Sent: 18 November 2016 11:05
To: Planning
Subject: NYM/2016/0441/LB Graystones Farmhouse, Newholm.
Attachments: Mrs Ailsa Teasdale NYM-2016-044-LB.pdf; Sliding Sash Window Crossection.jpg; Crossection through Sash.jpg; Proposed Window Design - Inside.JPG; Proposed Window Design - Zoomed In.JPG; Proposed Window Design.JPG

Dear Mrs Ailsa Teasdale

I have attached our letter in response to your letter of the 18th August regarding the NYM/2016/0441/LB planning application for Mr & Mrs Cuthbertson at Graystone Farmhouse, Newholm, Whitby. We have been asked to deal with the matters you raise in your letter as our clients thought it would be better if we answered your comments as we would be ones who manufacture the proposed windows.

I have also attached two cross-sectional drawings of the proposed window design and three photographs of some actually fitted windows of the proposed same design fitted at another property.

I would be grateful if you could acknowledge you have received this email/letter and confirm whether the proposed amendments would now be acceptable.

If you require any further information or wish to discuss anything then please do not hesitate to contact me.

Kind Regard

Mr. Chris Harrison
Managing Director
Robert Harrison & Sons
Building Contractors

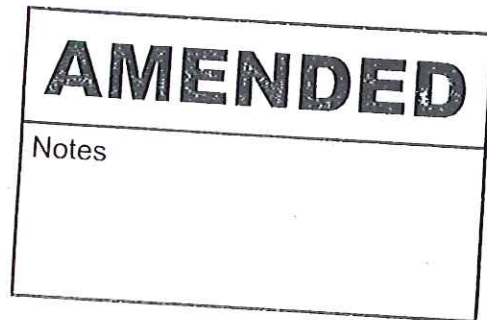



National
Federation of
Builders

Robert Harrison & Sons Ltd.

CARR END
GLAISDALE
WHITBY
NORTH YORKSHIRE
YO21 2QH

BUILDERS & CONTRACTORS
VAT NUMBER: 317348752
COMPANY No 4111931

AMENDED
Notes

Mr Ailsa Teasdale
North York Moors National Park Authority
The Old Vicarage
Bondgate
Helmsley
York
YO62 5BP

17/11/2016



Reference: NYM/2016/0441/LB – Greystones Farmhouse, Newholm, Whitby.

Dear Mr Ailsa Teasdale

We have been asked by Mr & Mrs Cuthbertson to write to you in regard to their planning application and their proposal to replace the existing front elevation windows at Greystones Farmhouse, Newholm.

Firstly as per your letter of the 18th August you state that the ground floor kitchen window contains older cylinder glass, our client's plan now is to retain and repair the original kitchen window while fitting secondary glazing as per your recommendations.

In regard to replacing the remaining windows on the front elevation, our client is proposing to fit traditional constructed sliding sash windows which would match the existing window design of the original kitchen window and thus preserve the architectural and historic character of the building. The proposed windows are to be manufacture from traditional hardwood. Our client's design ethos is that the proposed new windows will be in keeping with the historic character of the property and of the original historic windows. Therefore, we have designed the windows to be sliding sash, 4:10:4mm, argon filled, double glazed, windows hung on traditional sash cords and lead weights. They will have overlowed mouldings on the inside of the sash with a narrow 20mm glazing bar dividing each sash and all to be fully draft sealed and all hidden from view. In reference to the glazing bar please note that we have reduced the bulky 40mm glazing bar to 20mm in reference to your comments. Please see the enclosed cross section drawings of the proposed window design.

As a local joinery and building company we have manufactured and fitted many traditionally design, double glazed, sliding sash windows in various historical properties in the National Park which are designed to match the local vernacular window design. Please see the enclosed photographs of our

previous work. Therefore, the proposed windows will be in keeping with the historic character of the farmhouse.

I would be grateful if you could reflect on the amendments to the proposals as proposed by yourself and confirm whether these proposals are acceptable. If you require any further information or discussion regarding the situation then please do not hesitate to contact me.

Yours Sincerely



Mr C. Harrison
Managing Director



DOUBLE GLAZED SLIDING SASH WINDOW CROSSSECTION

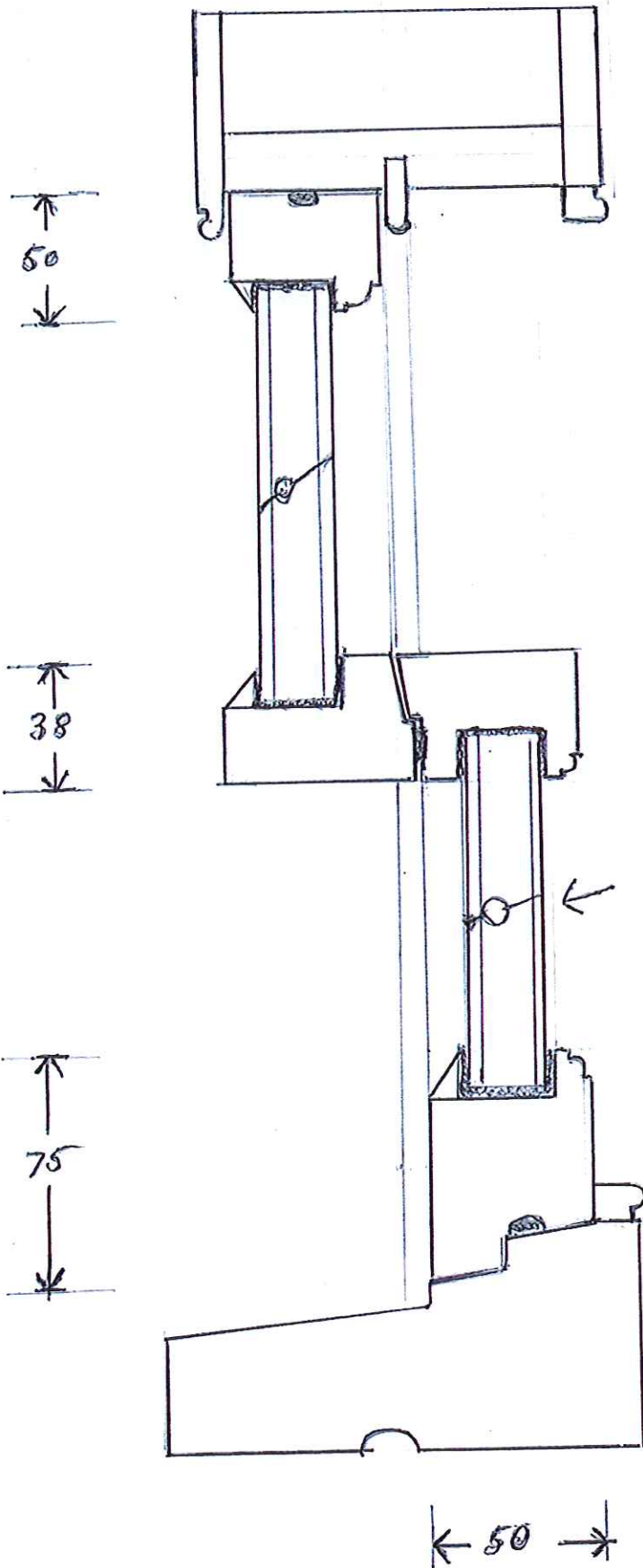

AMENDED

Notes

As original

NYMNP

18 NOV 2016

NYMNP
18 NOV 2016

CROSS SECTION THROUGH SASH

AMENDED

Notes

As original

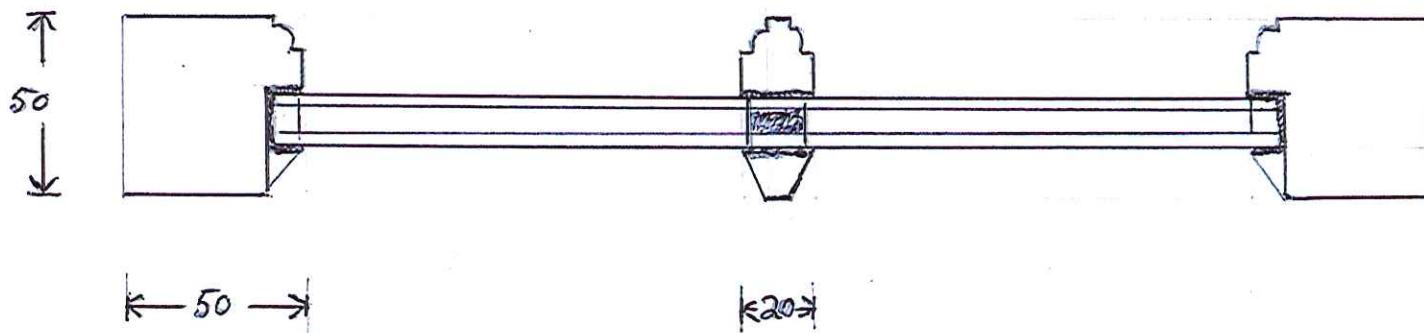

4/10/4 DOUBLE GLAZED UNIT WITH WHITE SOLID TRAPEZOID BAR

ALL INTERNAL MOULDED SECTIONS MORTISED TOGETHER

EXTERNAL BEADS WILL GIVE PUTTY POINTED APPEARANCE

AMENDE

Notes

NYMNP

18 NOV 2016

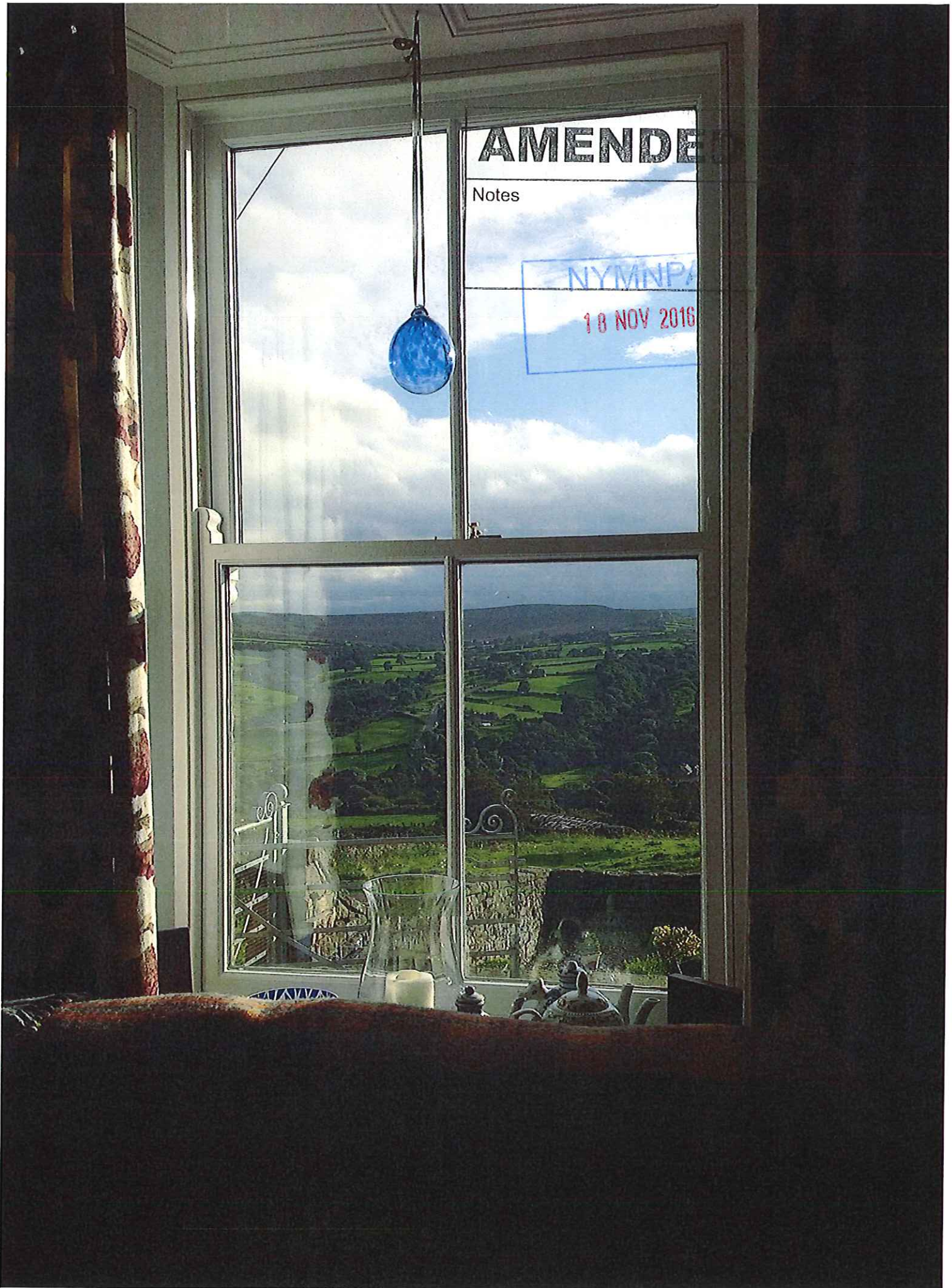

AMENDED
Note
Note





NYMINPA

18 NOV 2016

AMENDED

Notes

--