

5/7/18

Dear Edward

Further to our telephone conversation yesterday please find below confirmation of the work I intend to carry out at Beadle Cottage Robin Hood's Bay on behalf of Mr and Mrs Cross.

I hope the information is sufficient for your needs in determining their planning application, if you require any further information please feel free to contact me.

Entrance door,

The intention is to restore the original door casing and manufacture a new door to fit, this will be a four panel door with flat panels and mouldings to these. I have attached a photograph of the intended door type, the moulds will be of Robin Hoods Bay style and in keeping with the area.

Door furniture will again be of traditional style and as preferred by NYMNP a knob rather than lever handle will be used.

The ground floor window is to be replaced by an 8 over 8 traditional style sash window with both top and bottom sliding sashes, trickle vents will not be used. The glazing beads will be 20-22mm wide which is generally the nominal size found in Bay, we will install individual 4/4/4 or 3/4/3 Heritage double glazed units as supplied by slimlite or Heritage Glazing.

I did previously send a drawing of the proposed mould to be used I have attached this below for clarity.

Traditional putty will be used to seal the units.

There will be no horns or cill, the sashes will be of approximately 45mm x 35mm section

It is also proposed to install a stone cill to this window, dimensions of this have been previously supplied and are in keeping with other cills at adjoining properties. The cill will be sourced from a local quarry and will be cut to an appropriate profile. It is intended that this cill will sit on top of the existing stone work and cut into the stones either side. This will reduce the window dimensions by approx 160mm.

Window dimensions with cil approx 1650mm x 1495mm.

The first floor bathroom window, currently a casement style window will be replaced by a 2 over 2 traditional sliding sash window of appropriate proportions, this will have the same mouldings, profiles and sizes as the ground floor window and will again be glazed as the ground floor window.

No cill, horns or trickle vents will be used.

Approximate dimensions of 920mm x 625mm.

The first floor front bedroom window is a traditional Yorkshire horizontal sliding sash window.

This window as agreed previously will be replaced with a like for like replacement. We will send a small sample of the original mould to our knife suppliers and have a copy made this will ensure that the moulds used will be accurate.

Dimensions will be exact as per original allowing us to reuse the historic glass, there are 5 panes with cracks these will be replaced with salvaged mouth blown glass where possible, should new glass be required I will source high quality mouth blown cylinder glass from my suppliers in West Yorkshire.

The only exception to tradition is that we would like to install staff beads with hidden brush pile weather/draft strip this will give the client a more thermally appropriate window, these pile strips will be unseen from both inside and out.

The first floor rear bedroom window is in good condition and requires only minimal restoration though we would again like to install the brush pile to give good thermal protection, we will also replace the staff bead which will be of historic proportions and style.

The clients intend to have the whole front of the house repointed and this will be carried out using lime mortar by a licensed builder who will replace the pointing around the windows.

NYMNP

06/07/2018

Best Regards

Mark Laycock

FRONT GROUND FLOOR

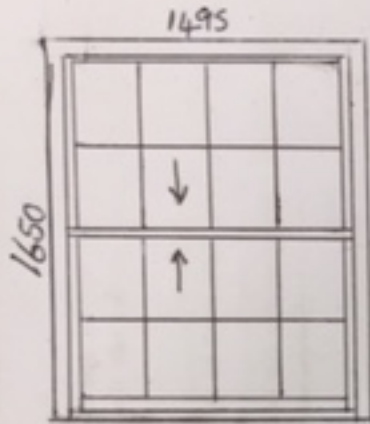

1st Floor Bedroom (Per)

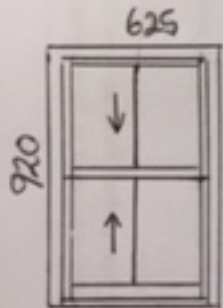

BEADIE COTTAGE

RHB NYM / 2017 / 0677 / LB

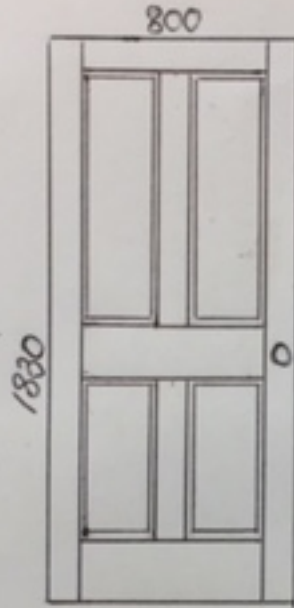

ENTRY DOOR

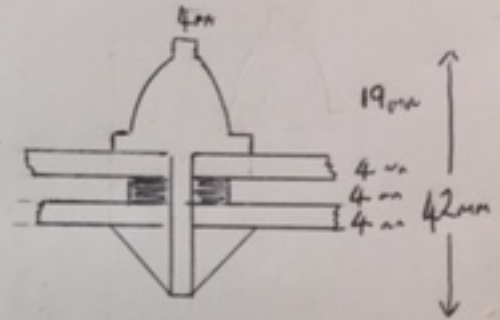

Mould for Replacement Sash Windows



King
of

NYMNP

06/07/2018

From:
To: [Planning](#)
Subject: NYM/2017/0677/LB
Date: 09 May 2018 20:00:14

Good afternoon

Our builder - Mark Laycock - has been in contact with Edward Freedman in order to finalise details of the work we need done on Beadle Cottage, New Road, Robin Hoods Bay.

In addition to the original submission we would like a window cill to be added. The details of this are shown in the diagrams below - as I believe Mark has already discussed with you.

I should be grateful if you could also take this into consideration along with the rest of the application

With many thanks

Jeremy Cross

∟

EXISTING

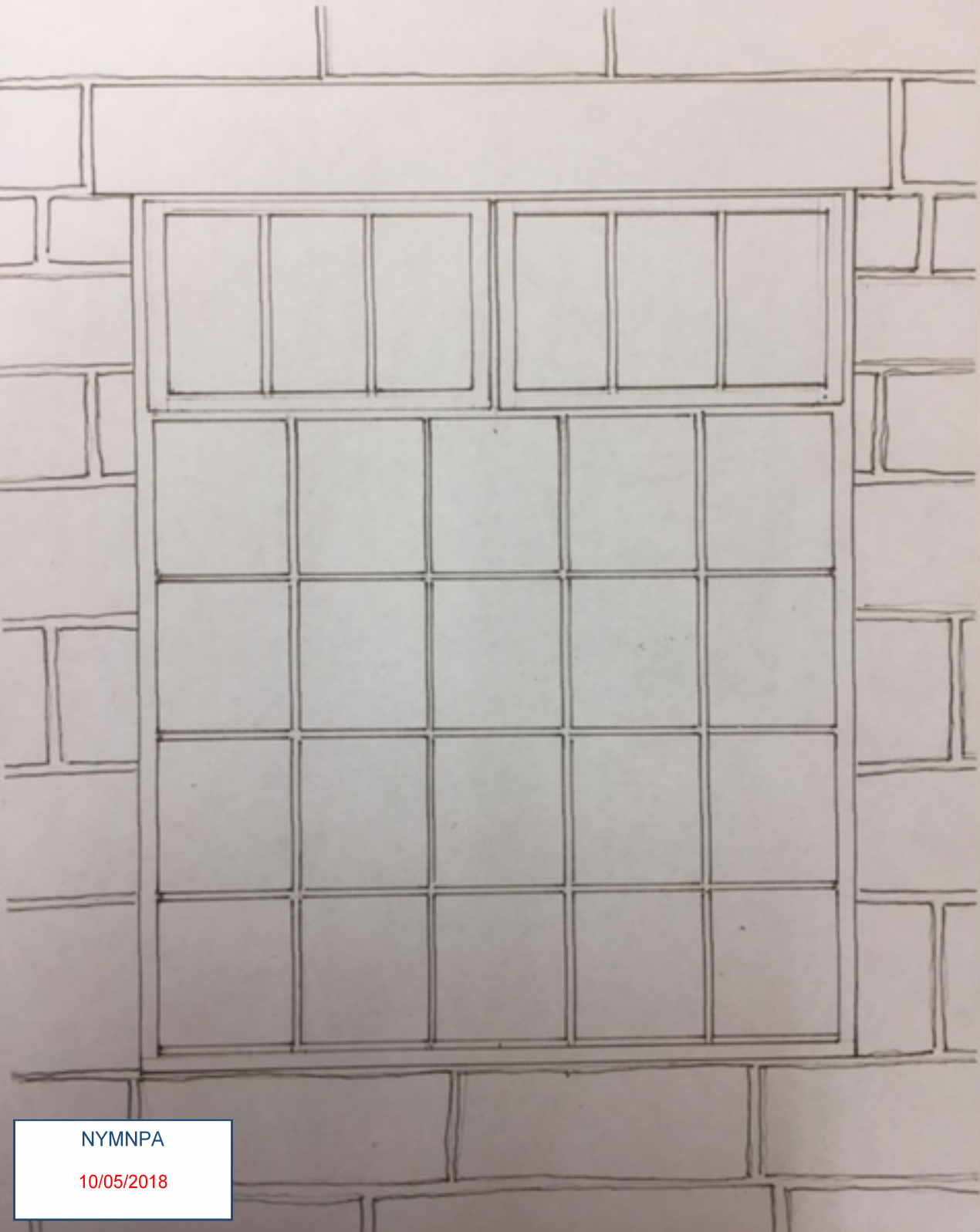

NYMNPA

10/05/2018

Proposed

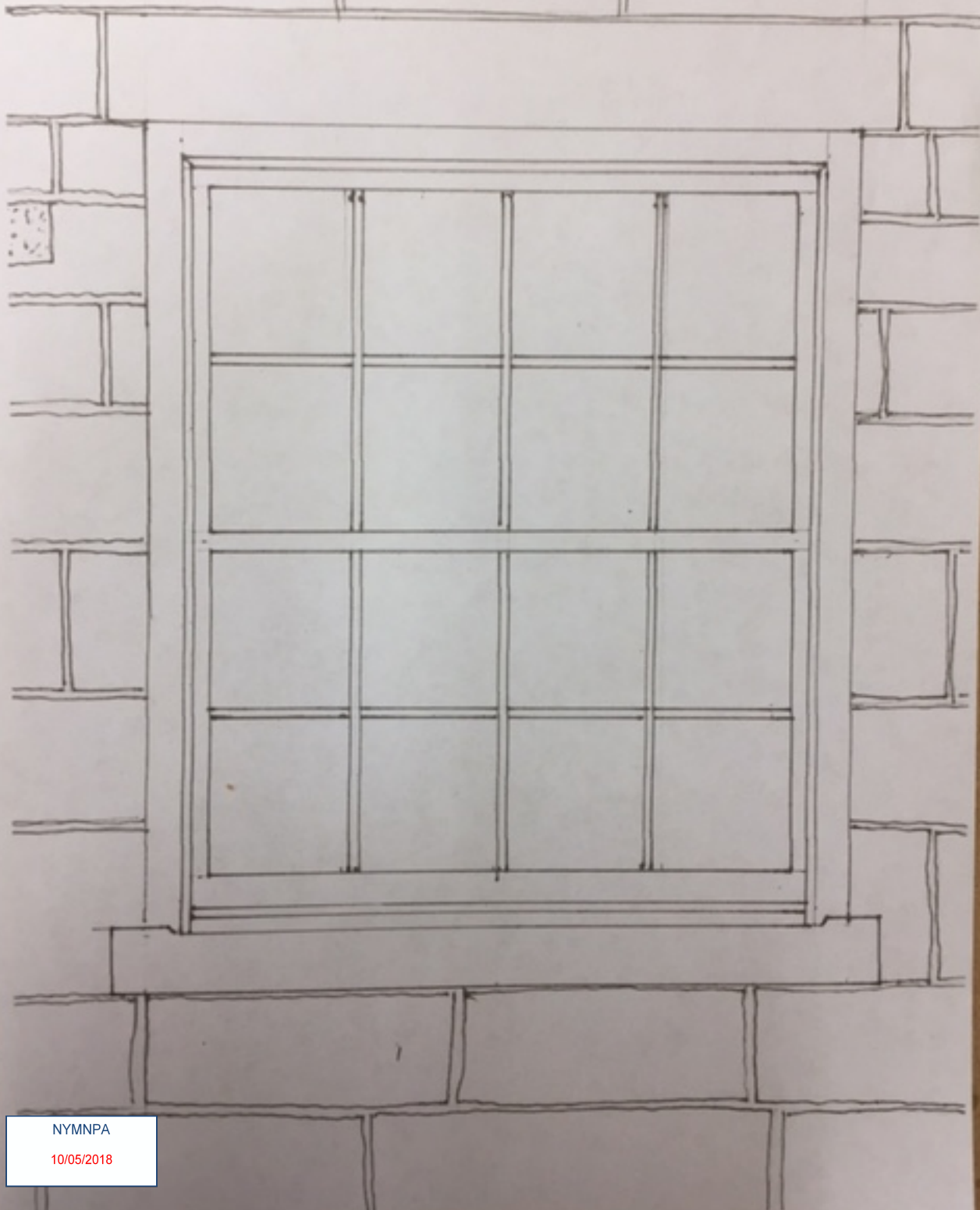

DEADLE COTTAGE

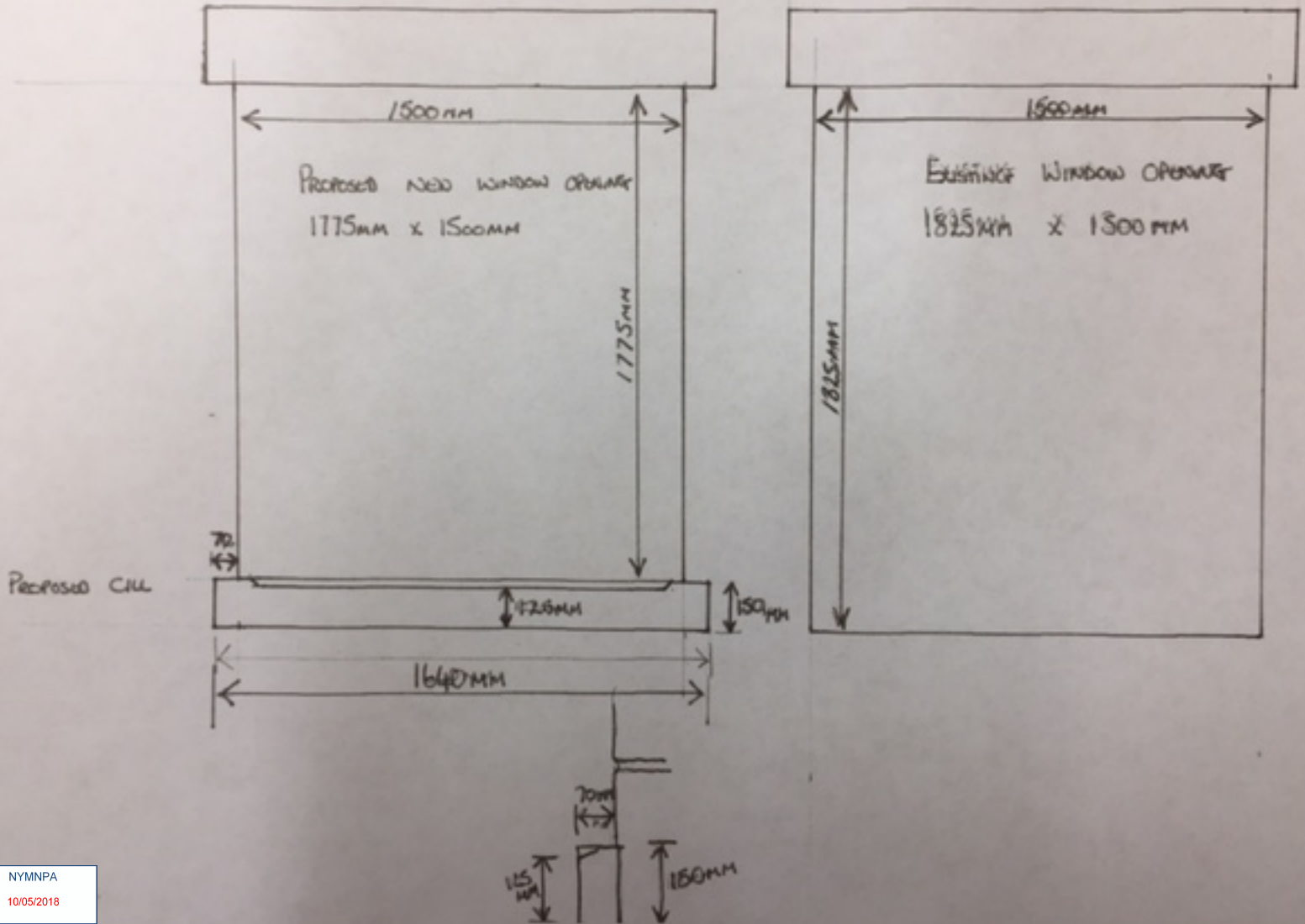

BEADLE COTTAGE

PROPOSED SASH WINDOW BEAD PROFILE

