

LEGEND

	SAFARI TENT PLUS DECKING
	SAFARI TENT BATHROOM
	COMPOSTING TOILET
	BELL TENT PLUS DECKING
	BELL TENT BATHROOM / TOILET
	KITCHEN UNIT
	EXISTING WOODLAND / HEDGE ROW
	NEW LANDSCAPING / PLANTING

REV. NO.	DESCRIPTION TO REVISION	REV. BY	DATE
A			
B			
C			
D			

NOTES:

© Crown copyright and database rights [03/11/2018]
 Ordnance Survey 0100031673



Survey, Measurement and Specialist Solutions for:
 Design - Construction - Refurbishment - Urban & Rural Development
 Transport Infrastructure - Mine and Quarry - Retail - Intelligent Data

CLIENT:	COAST & CAMPLIGHT
PROJECT:	COAST & CAMPLIGHT LOW RIGG FARM STAINSACRE WHITBY

TITLE:	PROPOSED SITE LAYOUT		
DATE:	NOVEMBER 2018		
GRID: ORDNANCE SURVEY	LEVEL: ORDNANCE SURVEY	DATA TYPE: 2D	OTHER DATA AVAILABLE: 3D MODEL: NO POINT CLOUD: NO UTIL & FULL ANALYSIS: NO
DRAWN BY: AB	SCALE @ AO: 1:500	PROJECT NO.: CR&C1	DRAWING NAME: CR&C1_COAST & CAMPLIGHT_PROPOSED LAYOUT

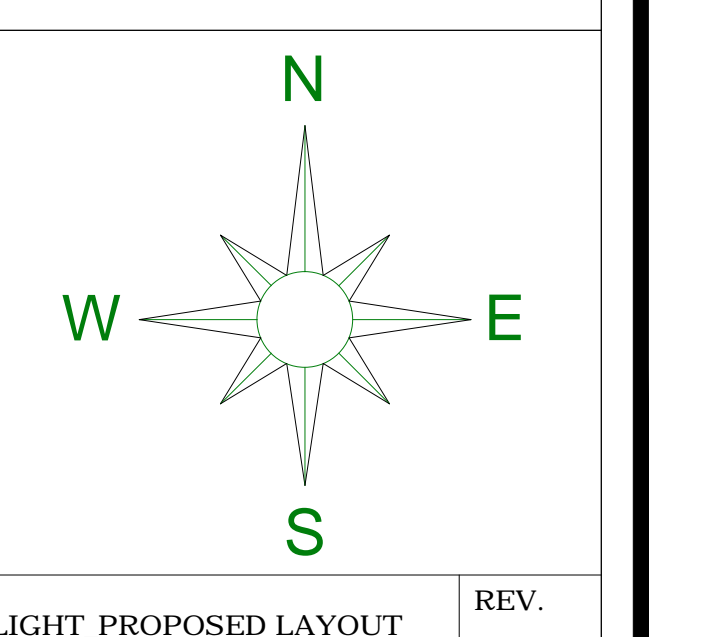

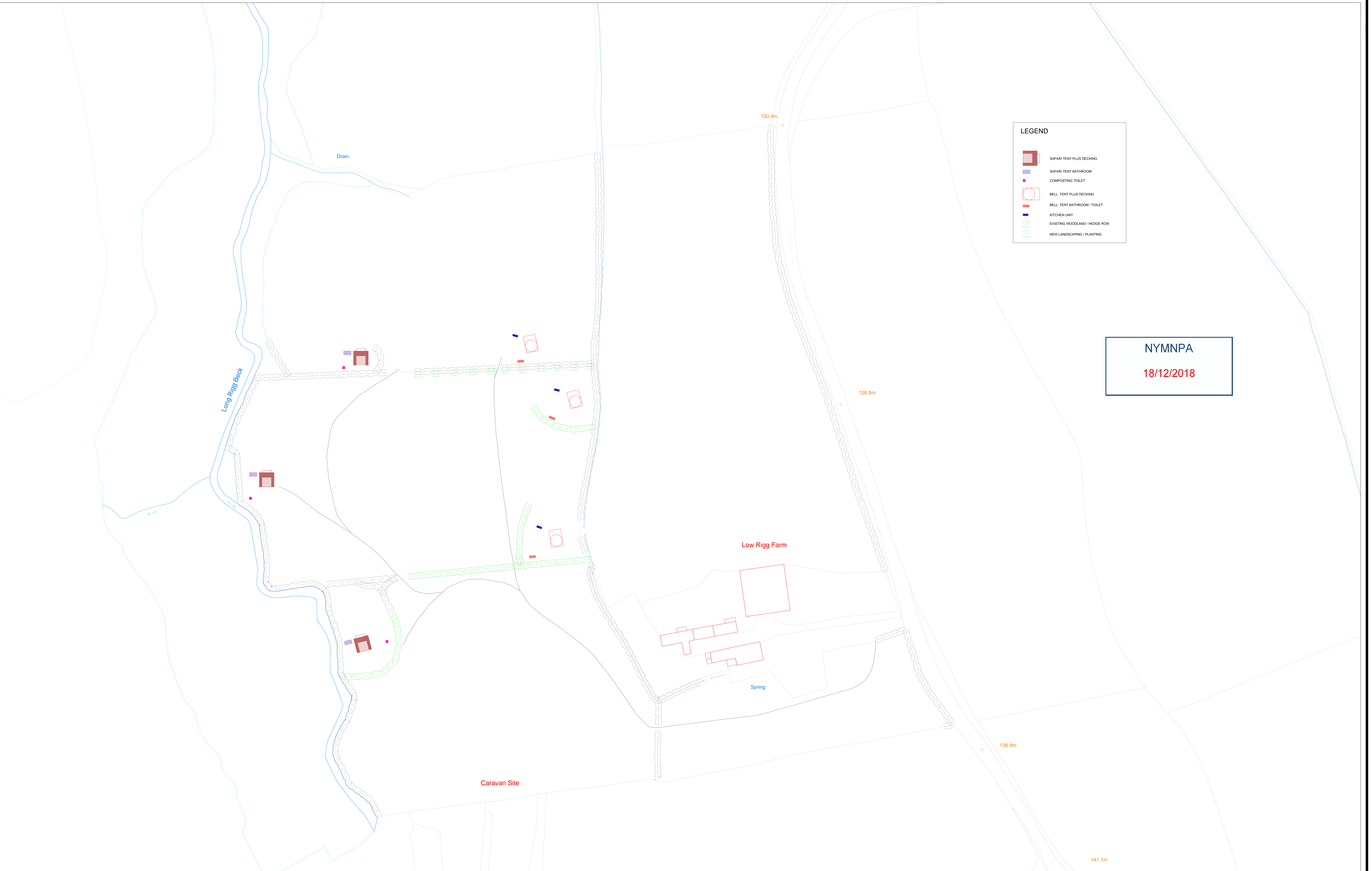

LEGEND	
	SAFARI TENT PLUS DECKING
	SAFARI TENT BATHROOM
	COMPOSTING TOILET
	BELL TENT PLUS DECKING
	BELL TENT BATHROOM / TOILET
	KITCHEN UNIT
	EXISTING WOODLAND / HEDGE ROW
	NEW LANDSCAPING / PLANTING

NYMNP
18/12/2018

REV. NO.	DESCRIPTION TO REVISION	REV. BY	DATE
A			
B			
C			
D			

NOTES:

© Crown copyright and database rights [03/11/2018]
Ordnance Survey 0100031673



Survey, Measurement and Specialist Solutions for:
Design - Construction - Refurbishment - Urban & Rural Development
Transport Infrastructure - Mine and Quarry - Retail - Intelligent Data

CLIENT:	COAST & CAMPLIGHT
PROJECT:	COAST & CAMPLIGHT LOW RIGG FARM STAINSACRE WHITBY

TITLE:	PROPOSED SITE LAYOUT		
DATE:	NOVEMBER 2018		
GRID: ORDNANCE SURVEY	LEVEL: ORDNANCE SURVEY	DATA TYPE: 2D	OTHER DATA AVAILABLE: 3D MODEL: NO POINT CLOUD: NO DEM: NO CUT & FILL ANALYSIS: NO
DRAWN BY: AB	SCALE @ AO: 1:500	PROJECT NO.: CR&C1	DRAWING NAME: CR&C1_COAST & CAMPLIGHT_PROPOSED LAYOUT

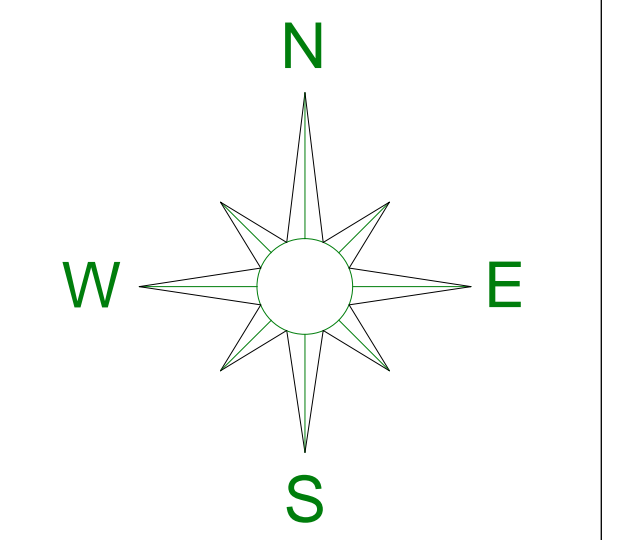

Bell tents

Our bell tents are primarily aimed at couples, but can accommodate families if required and will provide futons for children. The bell tents will provide luxury sleeping accommodation and the decking area outside will allow for a table and chairs for seating.

The decking will be provided beneath each bell tent to provide a solid flat base, which is particularly necessary as the land at Low Rigg Farm is sloped/uneven in almost all areas. We have taken care with our choice of the sites on the farm, but all areas have some level of unevenness.

Note: all measurements in mm unless otherwise stated.

Figure 1. Bell tent on base (for illustration purposes only)



NYMNPA

18/12/2018

Figure 2a and 2b bell tent dimensions

NYMNPA
18/12/2018

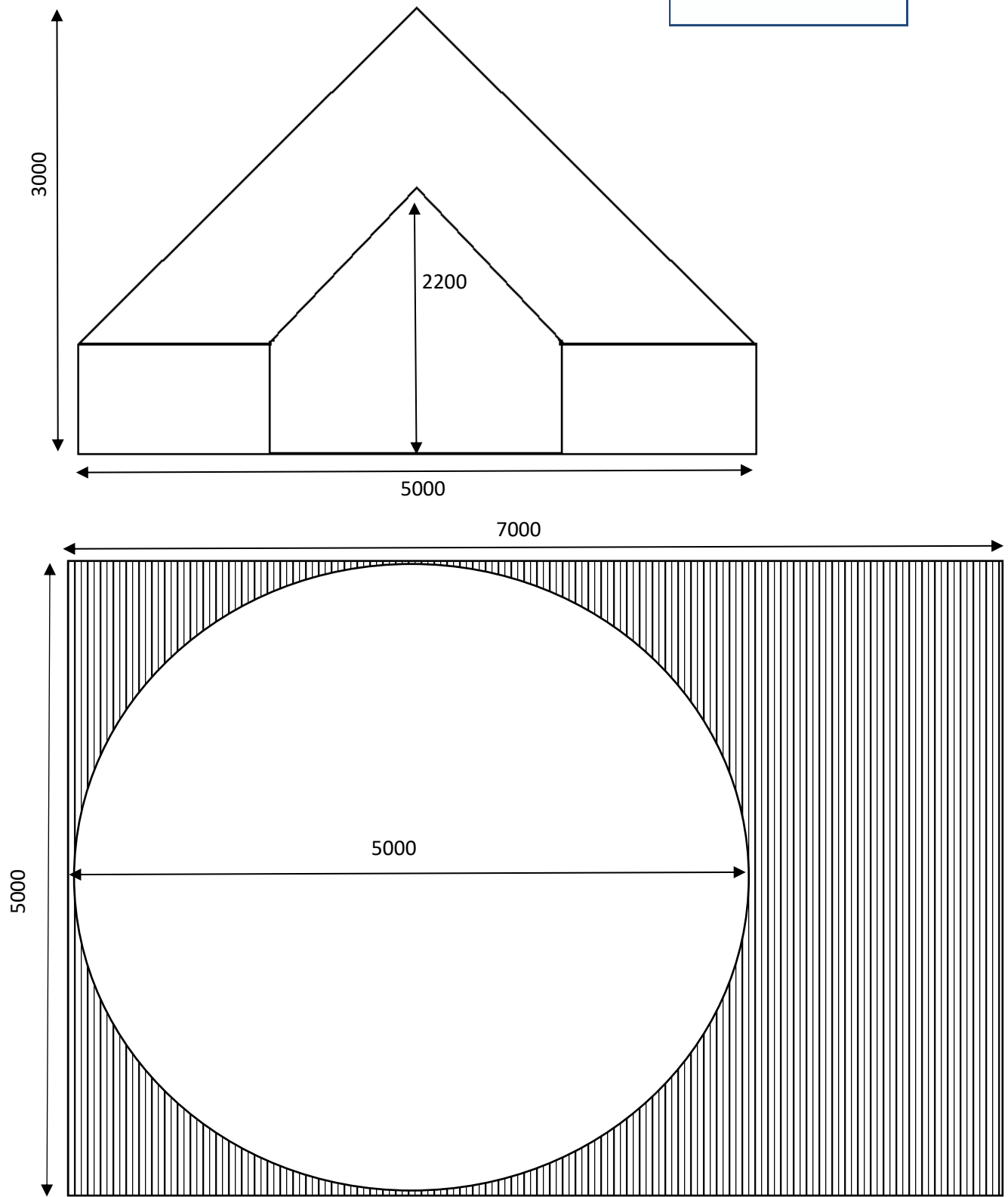

Bell tent bases

We will build bases for the bell tents in a similar fashion to those provided by Outstanding for the safari tents. The difference being we will have no minimum ground clearance and where the land is the highest we anticipate the decking will touch the ground to minimise the gap between the ground and the deck. If necessary we will dig into to the ground to site the base, making it as unobtrusive as possible.

The base will then be covered with a timber decking surface and the bell tent will sit on top of this.

Figure 3 shows the proposed dimensions of the bell tent base.

Figure 3. Bell tent base

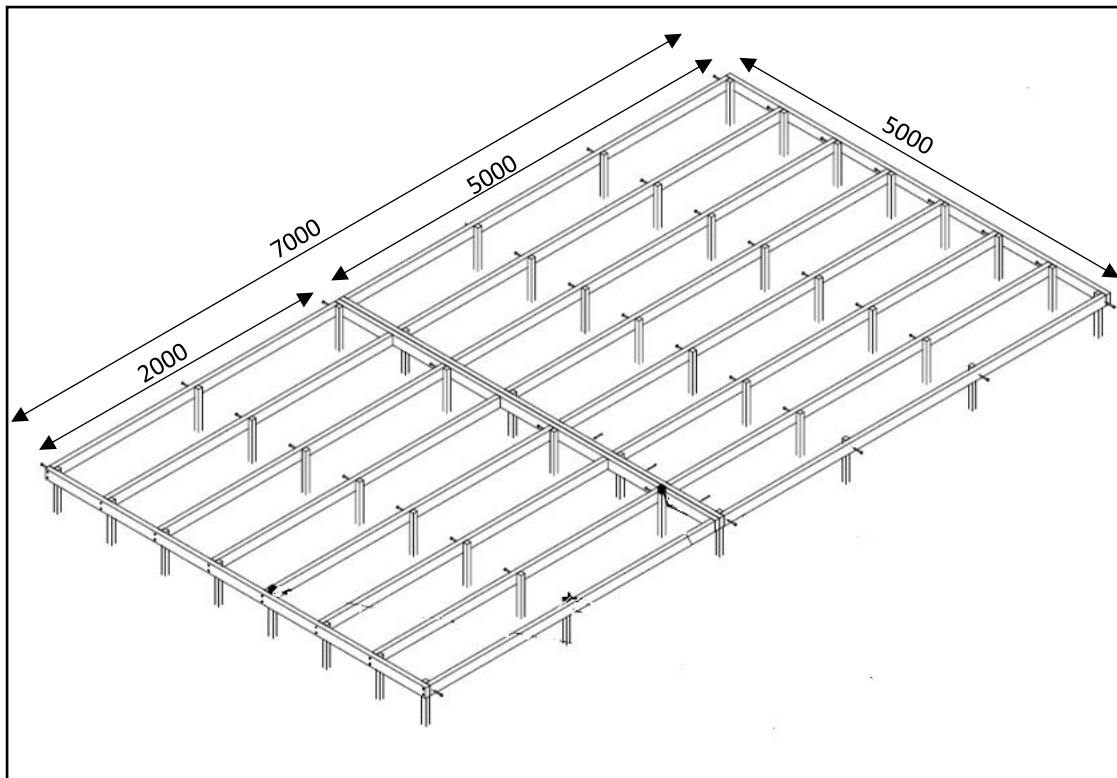

NYMNPA

18/12/2018

Bell tent kitchen

The bell tents do not have space for an integral kitchen area, therefore we will provide a very simple kitchen area outside the tent to allow guests to cook. This will have a camping gas hob and a sink for washing pots and pans. This will be made on site by us of predominantly timber construction.

Figure 4a shows the kitchen unit dimensions, and figure 4b is an image of the type of kitchen unit we propose.

Figure 4a. Bell tent kitchen unit

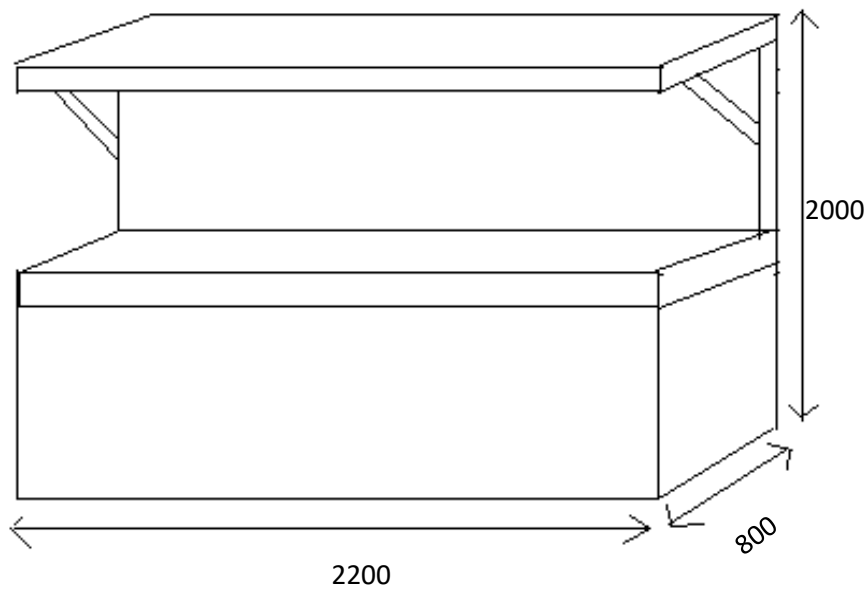

NYMNPA

18/12/2018

Figure 4b. Image similar to proposed kitchen unit (for illustration purposes only)



Bell tent bathroom

All units on site are aimed to be a luxury stay – we believe that to achieve this that each unit needs to have en-suite bathroom facilities, or as close to that as we can manage in a field! Each bell tent will have its own bathroom with toilet and shower. As we are keen to limit the number of new structures in the landscape (and the bell tents have the outdoor kitchen units) the bathrooms for the bell tents will have both shower and composting toilet as part of one structure.

Figure 5a shows the bathroom unit dimensions, and figure 5b is an image of the type of bathroom unit we propose.

Figure 5a. Bell tent bathroom unit dimensions

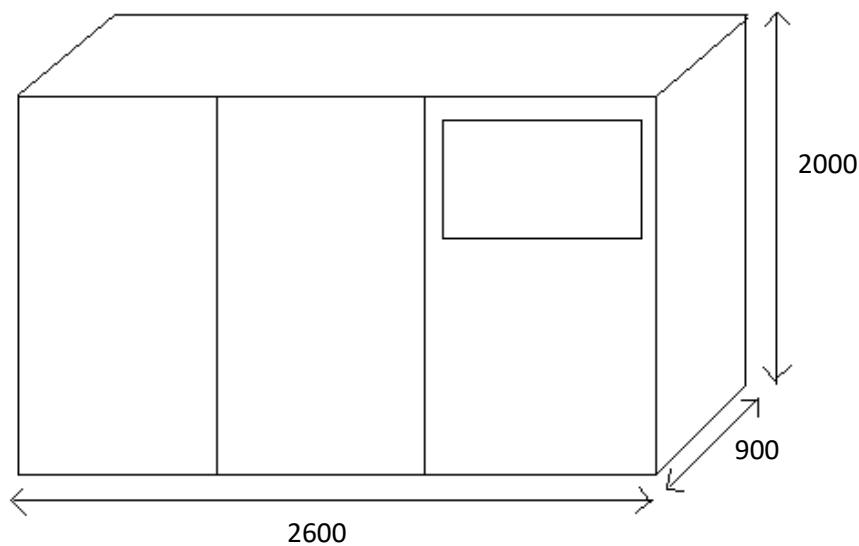

Figure 5b. Image similar to proposed bathroom unit (for illustration purposes only)



Safari tents

We aim for our safari tents to be our luxury family option, giving greater space for 2 internal bedrooms and an integral kitchen area. An outside decking area with overhang from the tent will allow families to enjoy the beautiful national park while still being under cover (allowing for the North Yorkshire weather!).

We will source our safari tents from Outstanding Tents, Figure 1 is an image of the model we have chosen (AN3 compact). More images are available from <https://www.outstandingtent.co.uk>

Figure 1



NYMNP

18/12/2018

Dimensions of the chosen safari tents are provided in the images below. Note: all dimensions given in mm unless otherwise stated.

Figure 2a and 2b. Safari tent dimensions

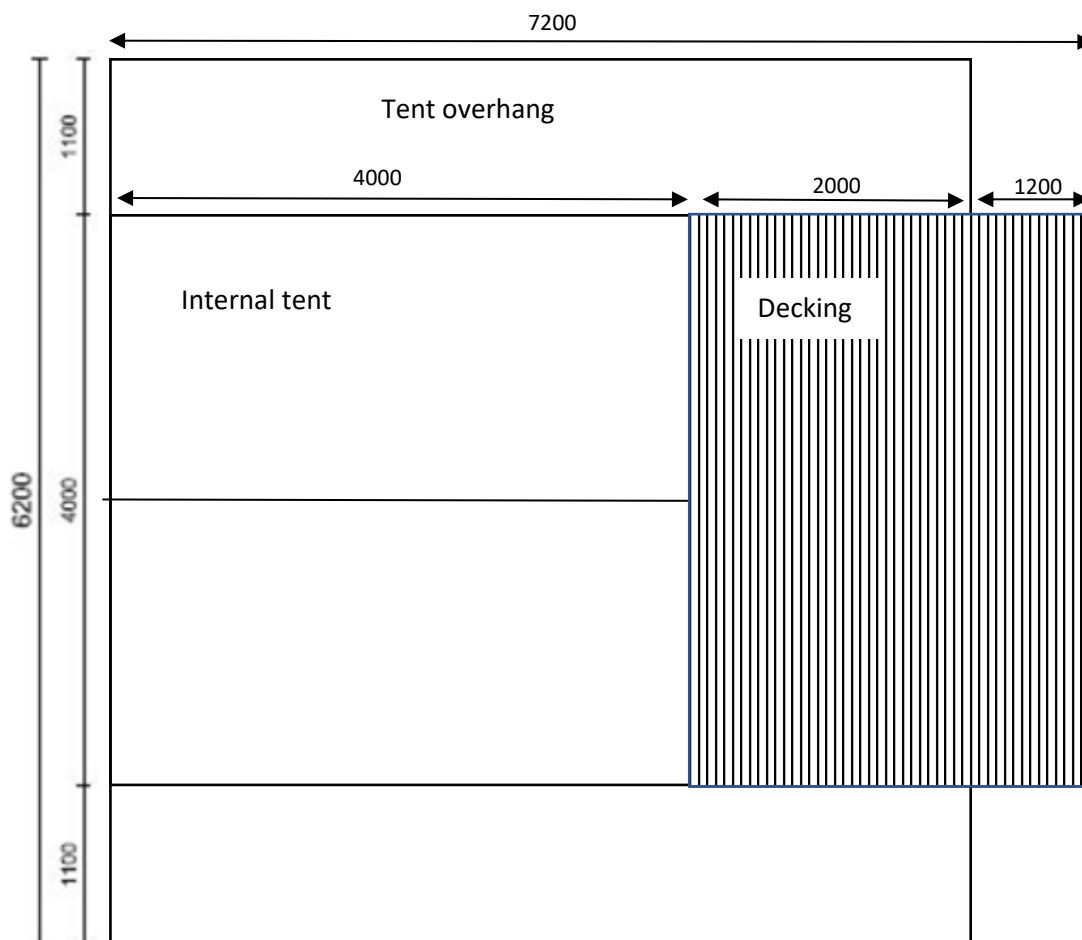
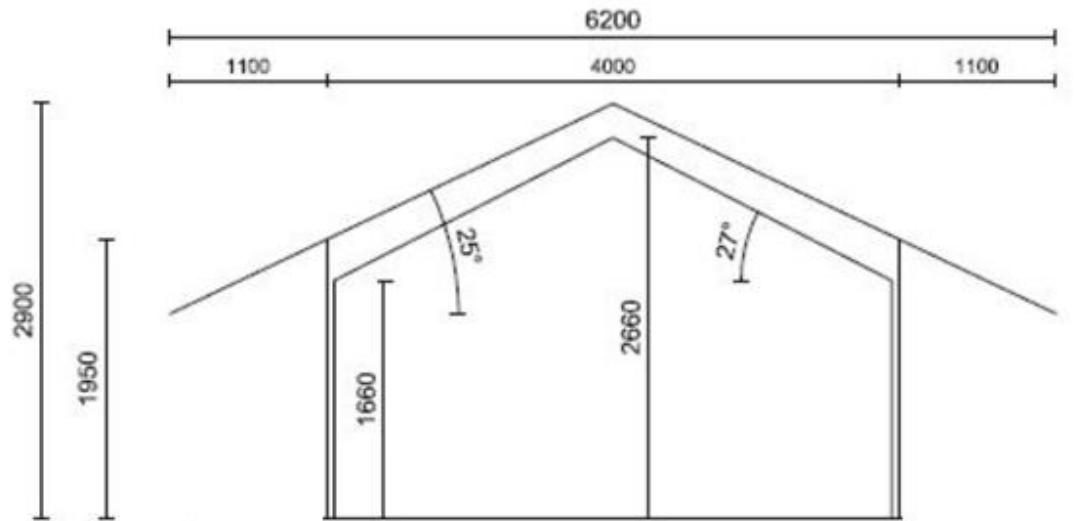

NYMNPA

18/12/2018

Safari tent bases

The safari tents are fitted as standard with a base by Outstanding. Figures 3a and 3b below show the base dimensions. These bases will then have timber decking overlaid on top of the base, and the safari tent will sit on top. Dimensions in cm.

Figure 3a

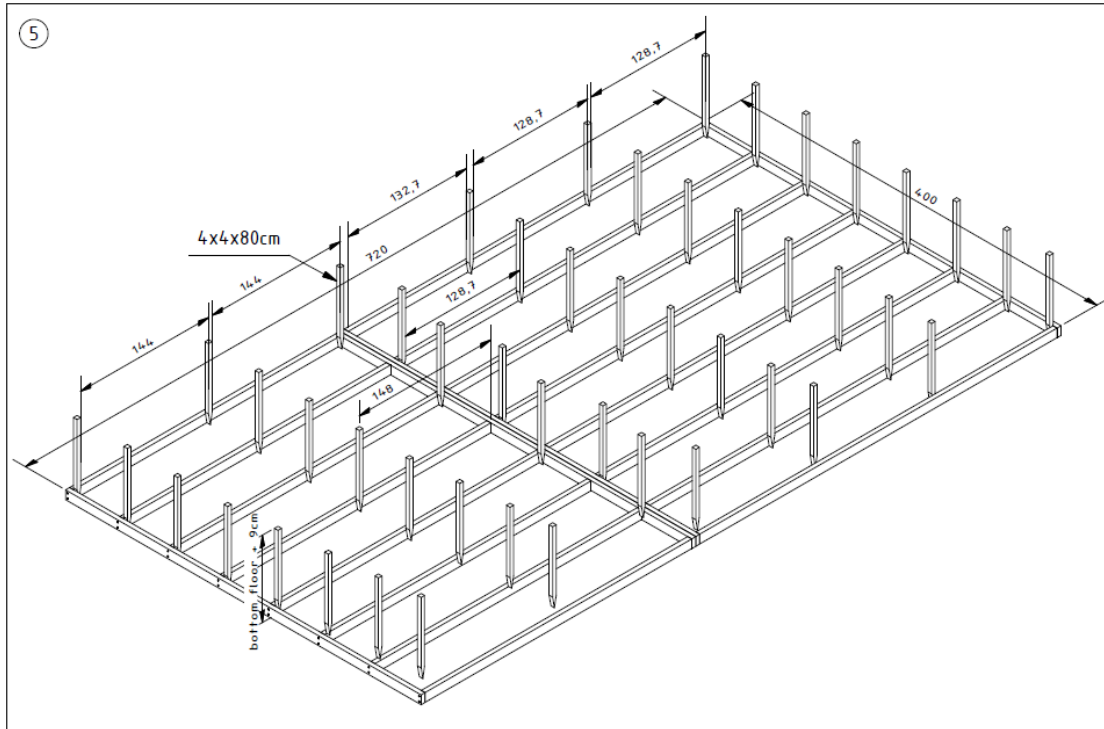
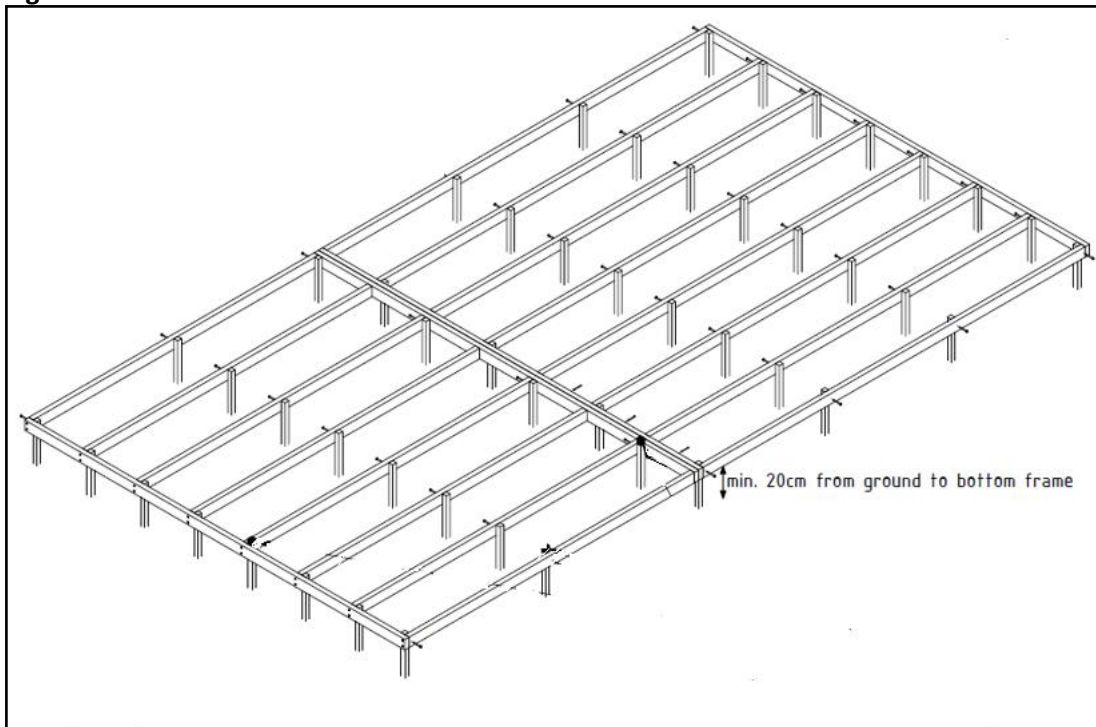

Figure 3b



Safari tent outbuildings

The safari tents are aimed at families with children, therefore we have designed these to have a larger bathroom closer to the tent. These bathrooms have a large enough sink to use as a baby bath and seating areas in the unit so children can be accommodated whilst the adults are showering. These will look very similar to the smaller bathroom unit (image provided in bell tent specification). In these units the composting toilet is separate and is a simple shed like structure. Figures 4 and 5 show the dimensions of the safari tent bathroom and composting toilets.

All units will be made by us on site of a simple timber shed like construction, they will be left unpainted aiming to blend in with the environment as much as possible.

Figure 4. Safari tent bathroom

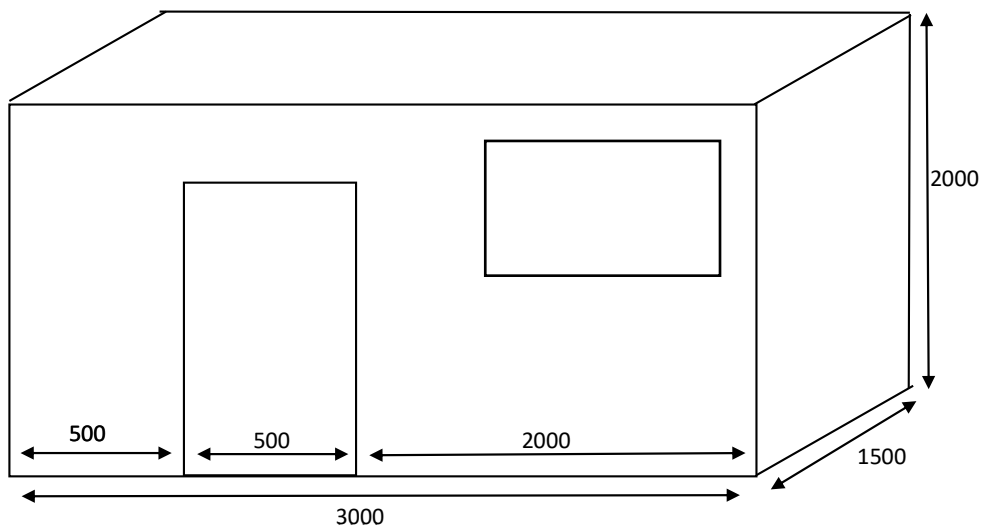
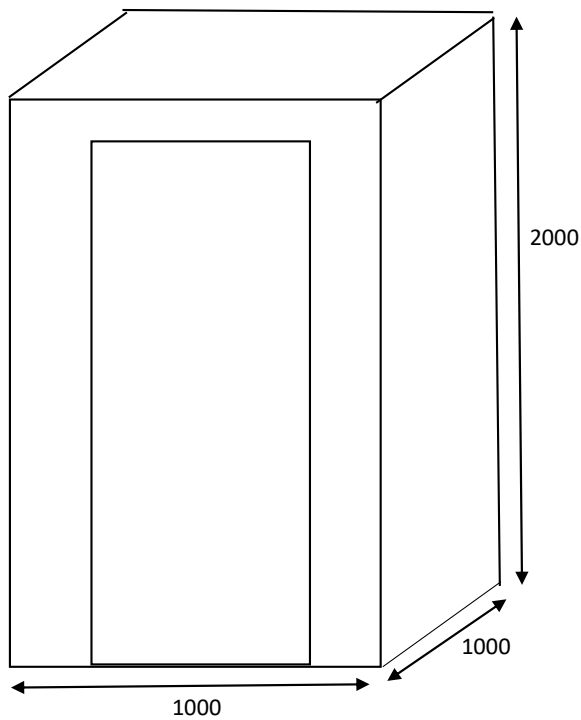

Figure 5. Composting toilet



NYMNPA
18/12/2018