

Amendments/Additional Information

- Amended layout of buildings/outside areas
- Additional background information - *joinery details.*
- Amended design
- Revised access arrangements
- Change of description of proposed development
- Change in site boundaries
- Other (as specified below)

.....

.....

.....

.....

Helen Webster

From: John Eisenberg ·
Sent: 04 July 2017 17:13
To: Helen Webster
Subject: Re: NYM/2017/0278/FL - 8 The Esplanade

NYMNPA
05 JUL 2017

Hi,
Thanks for this information.
Just to confirm we are happy for the new ensuite soil pipe to be brought down internally through the property
BW
John Eisenberg

Sent from my iPad

On 4 Jul 2017, at 11:23, Helen Webster <h.webster@northyorkmoors.org.uk> wrote:

Dear Mr Eisenberg

I have completed my recommendation for your application at 8 The Esplanade, Robin Hoods Bay and would anticipate it being issued by the end of the week. However, during the final checks, I have noticed that Edward requested that the new soil pipe from the en-suite to be brought down internally through the property rather than as an additional external pipe (email sent 24 May 2017) but I don't think we have had a response from you on this matter.

I would be grateful if you could confirm whether this would be acceptable to you.

With best regards
Helen

Miss Helen Webster
Planning Officer, Development Management

North York Moors National Park Authority
The Old Vicarage, Bondgate, Helmsley, YORK, YO62 5BP
t: 01439 772700
e: planning@northyorkmoors.org.uk
w: www.northyorkmoors.org.uk

Normal Working Hours:
Mon to Fri - 9:00am to 5pm

AMENDED
Notes

Helen Webster

From: Stephen Straw
Sent: 16 June 2017 12:42
To: Helen Webster
Subject: Re: 8 esplanade, robin hoods bay
Attachments: box sash 45mm sash sg.TIF; Box sash Window next door.JPG; Whitby Sash Section Detail 15th June 17 001.jpg; Whitby Sash Window next door.JPG; Window elevation drawings 15th June 17.pdf; Yorkshire Sash Window single glazed.tif; Yorkshire sash Window next door.JPG; Yorkshire Sash Window.tif

Hi Helen

see attached for documents RE windows at 8 the esplanade in robin hoods bay.

if you need anything else let me know.

regards

James @

P M Straw Builders Ltd



Address:
Unit 5 Station Workshops
Station Road
Robin Hoods Bay
Whitby
North Yorkshire
YO22 4TG.

Box sash window section

January 11

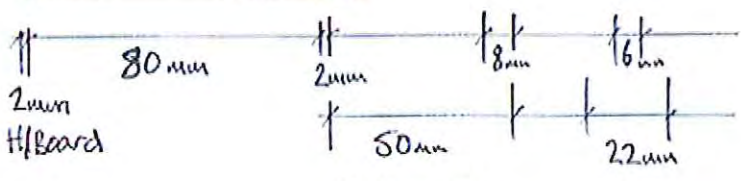
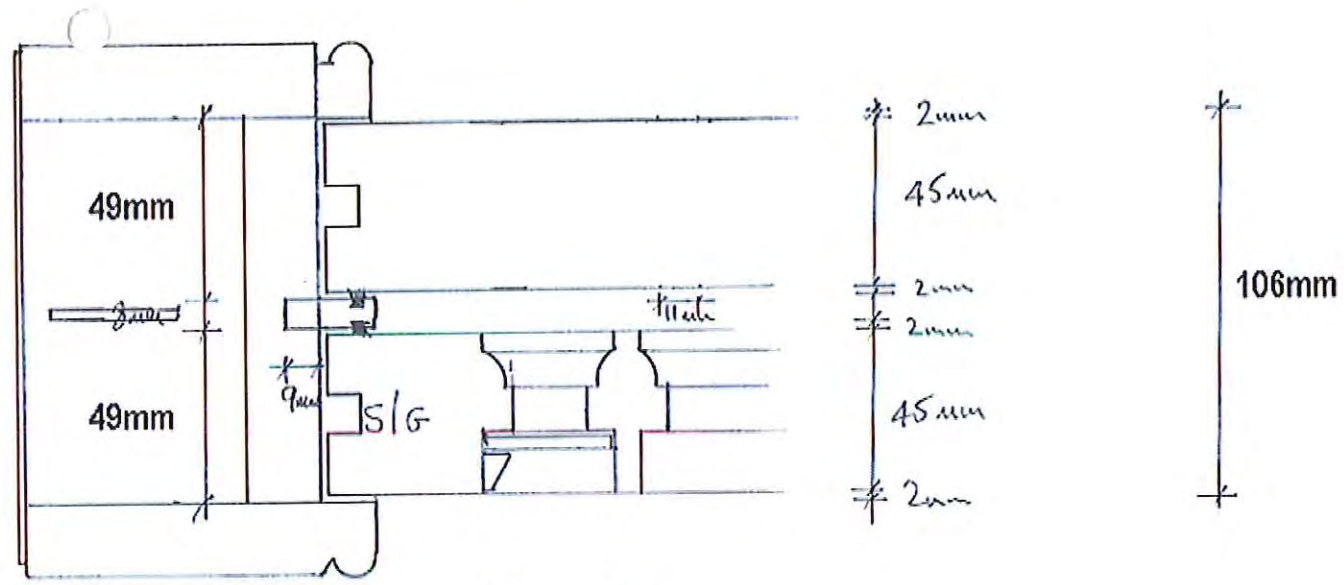

To suit 45mm sashes

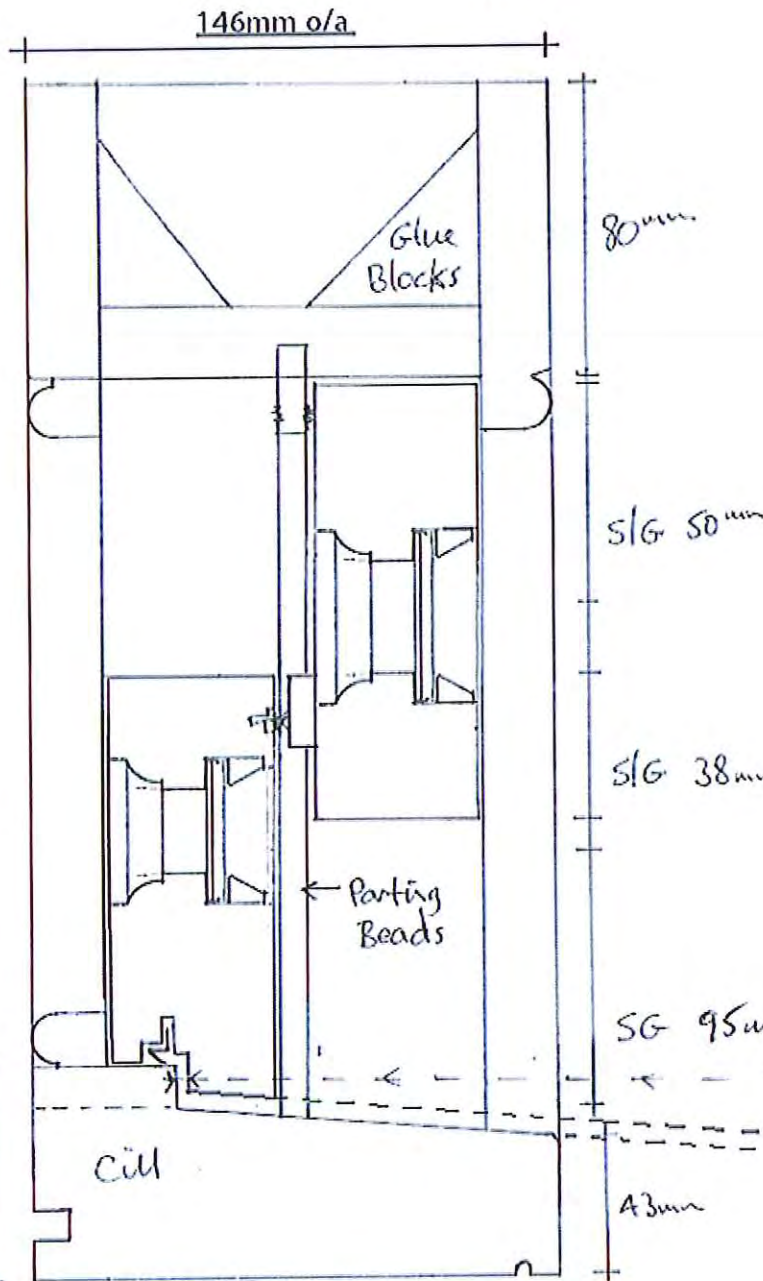

NYMNP
16 JUN 2017

← Minimum 5mm clearance
← Minimum 4mm clearance

68mm
Cill



NYMNP
16 JUN 2017

Whitby Sash Window
15" June 2017

Horizontal Section A-A

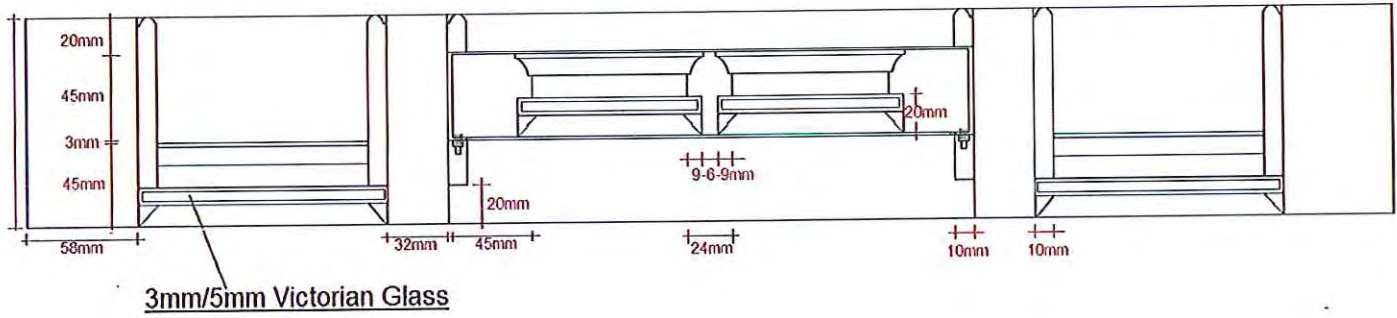

Horizontal Section B-B

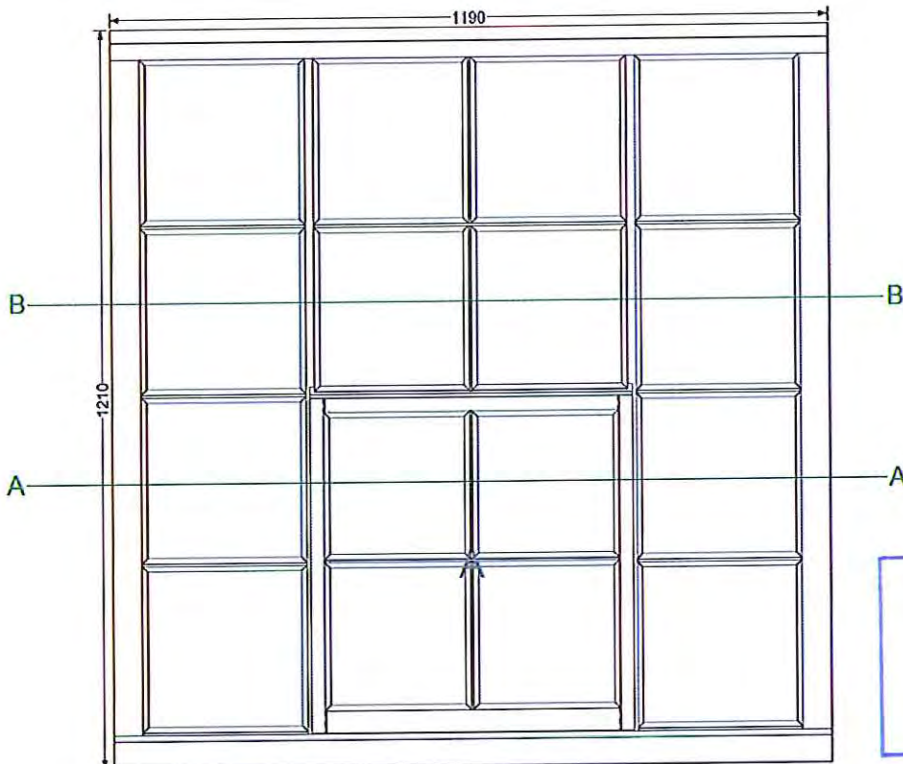
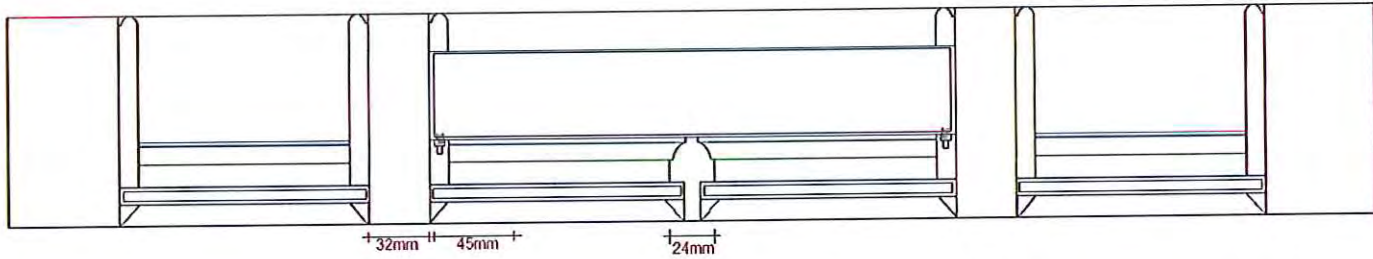

NYMNP
16 JUN 2017



NYMNP
16 JUN 2017

Client P.M Straw

Job No 8 Esplanade, Robin Hood's Bay - SLIMLITE Option

1 X Door & Frame - FRONT DOOR

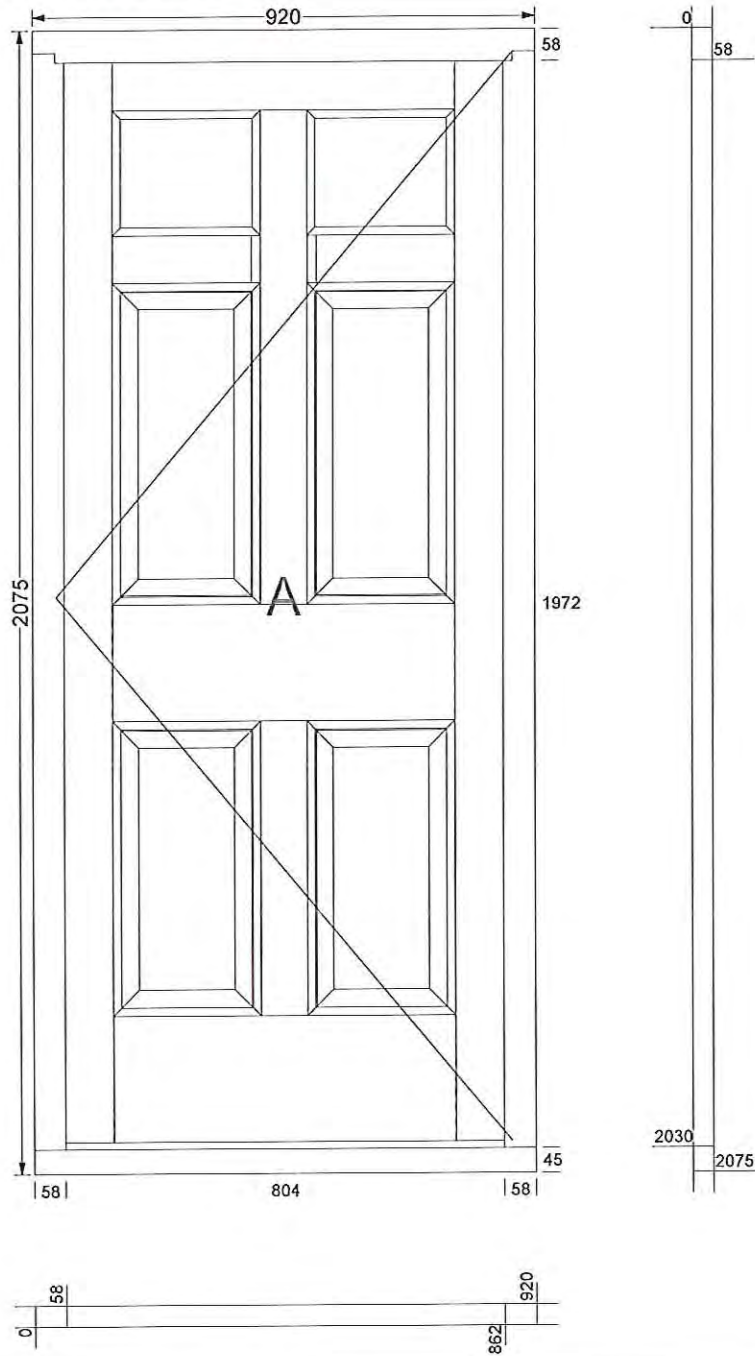

NYMNPA
 16 JUN 2017

1 X Sliding Sash - 2ND FLOOR (Front)

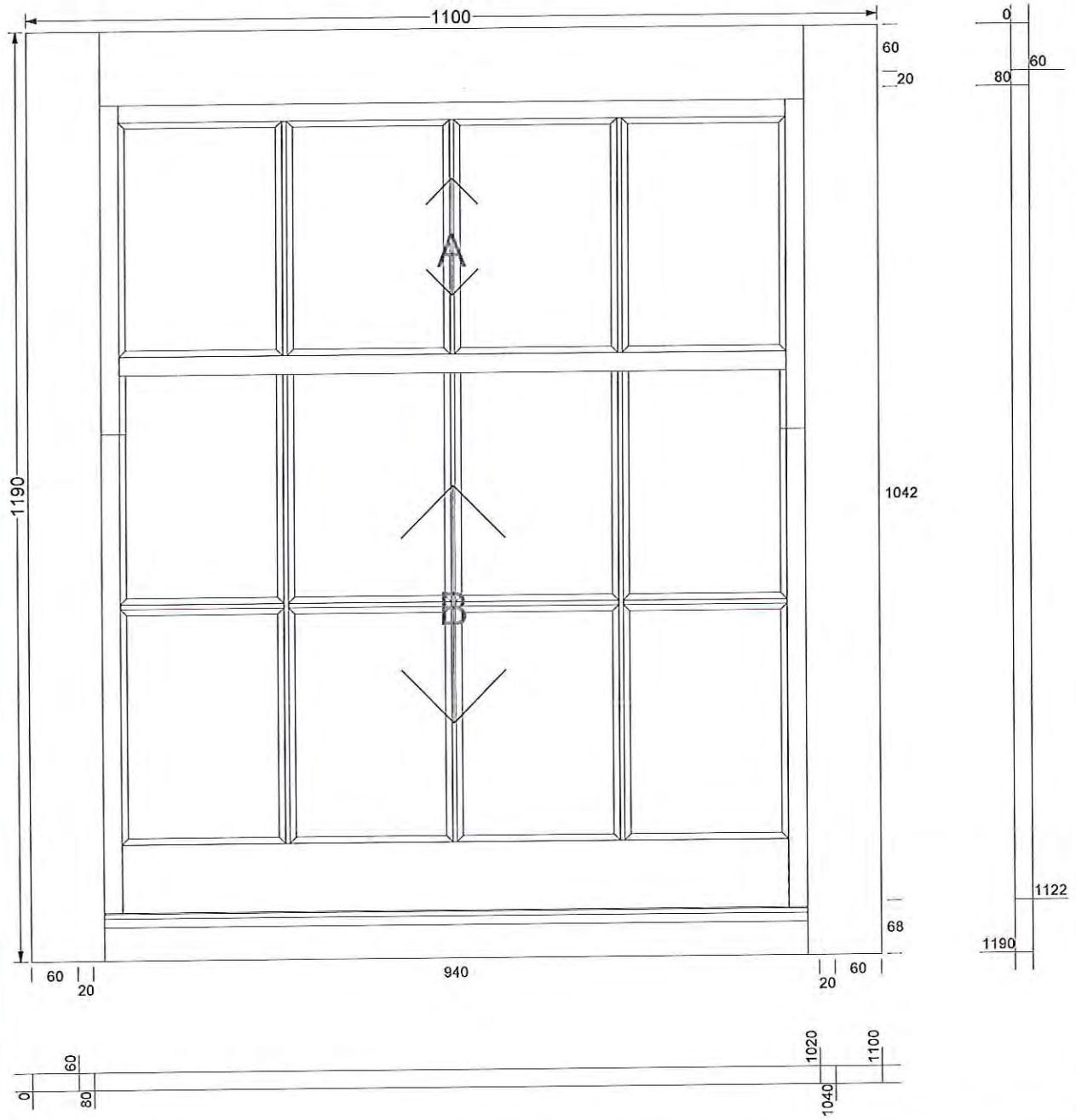

NYMNP
16 JUN 2017

1 X Sliding Sash - GRD FLOOR (Front)

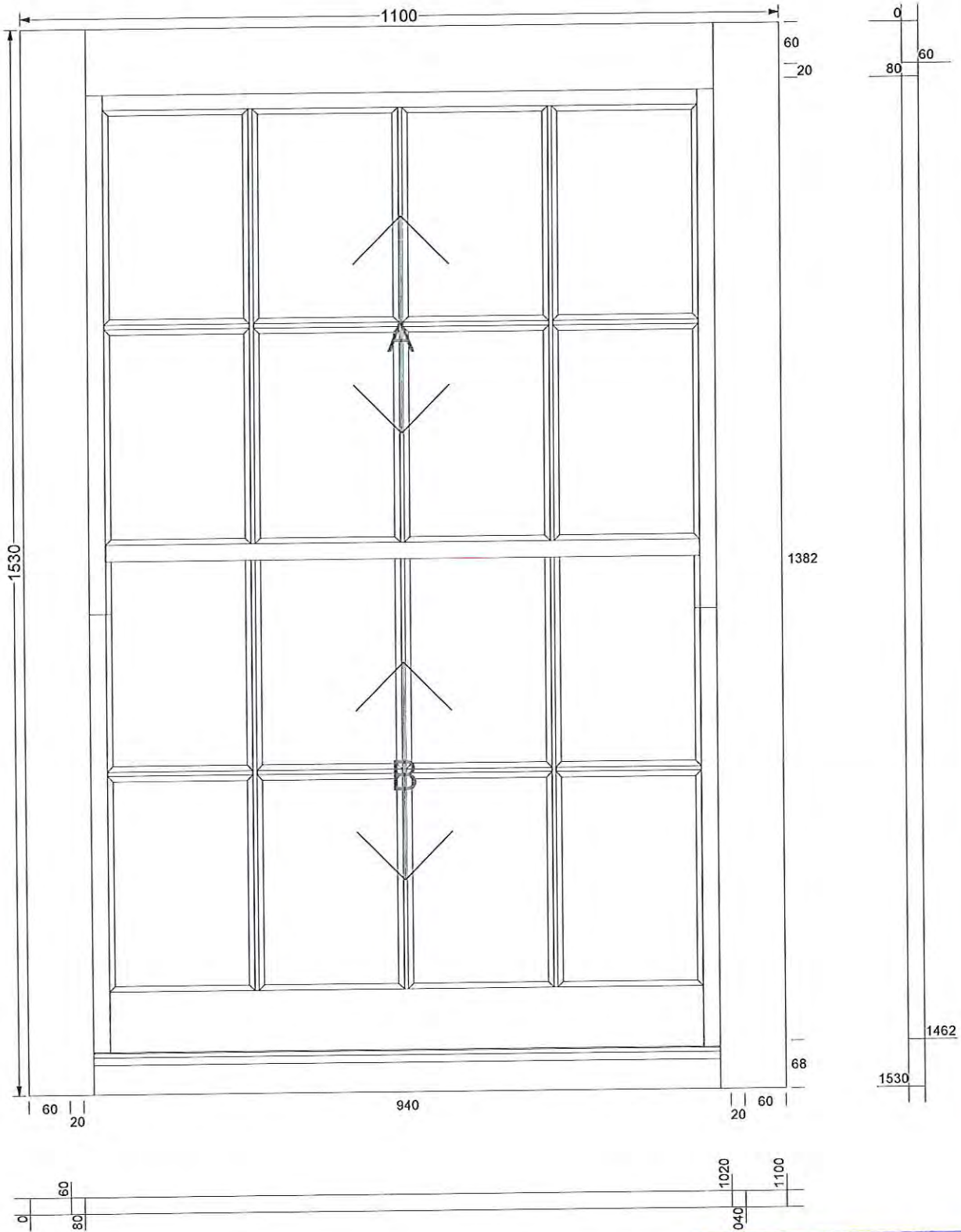

NYMNP
16 JUN 2017

1 X Vertical Sliding - REAR ELEV (Whitby)

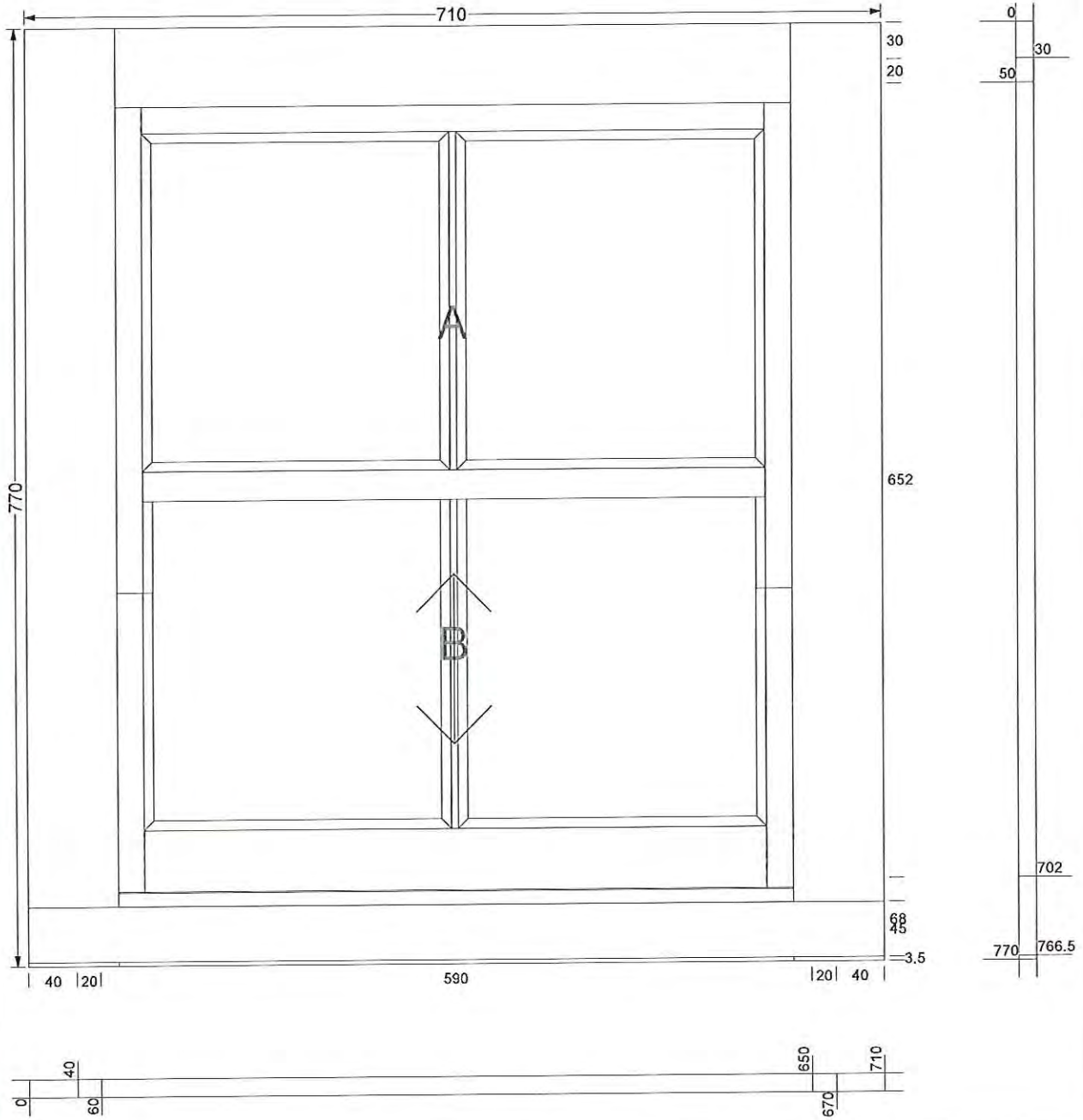

NYMNPA
16 JUN 2017

1 X Window - REAR ELEV (Kitchen)

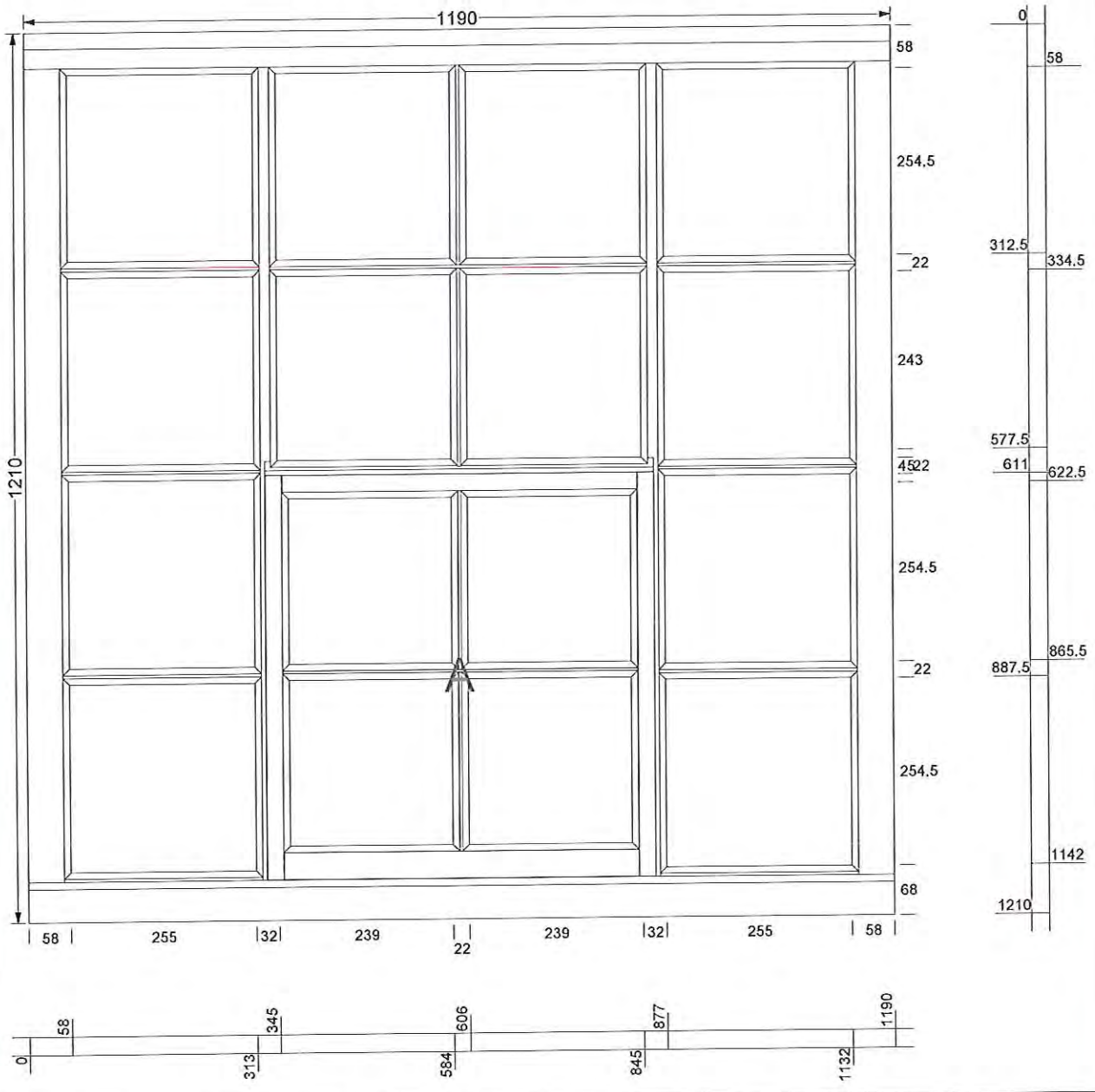

NYMNPA
16 JUN 2017

1 X Sliding Window Frame - DORMER (Kitchen)

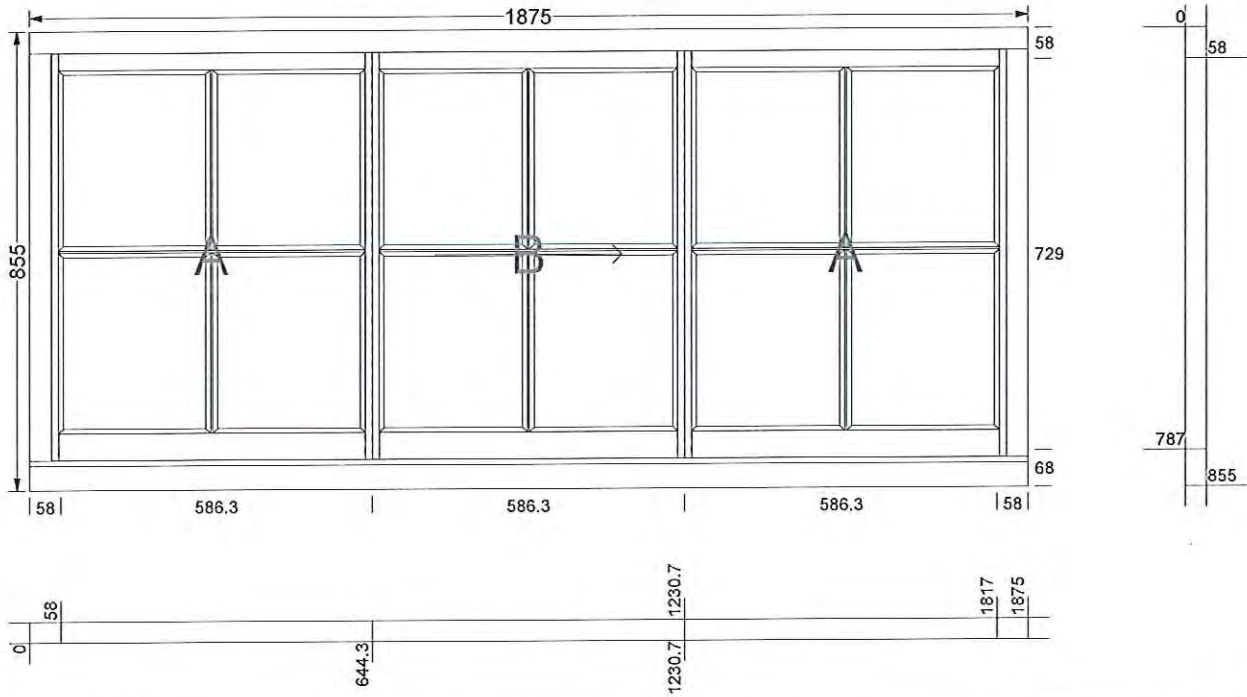

NYMNPA
16 JUN 2017

SECTION @ OPENING SASH

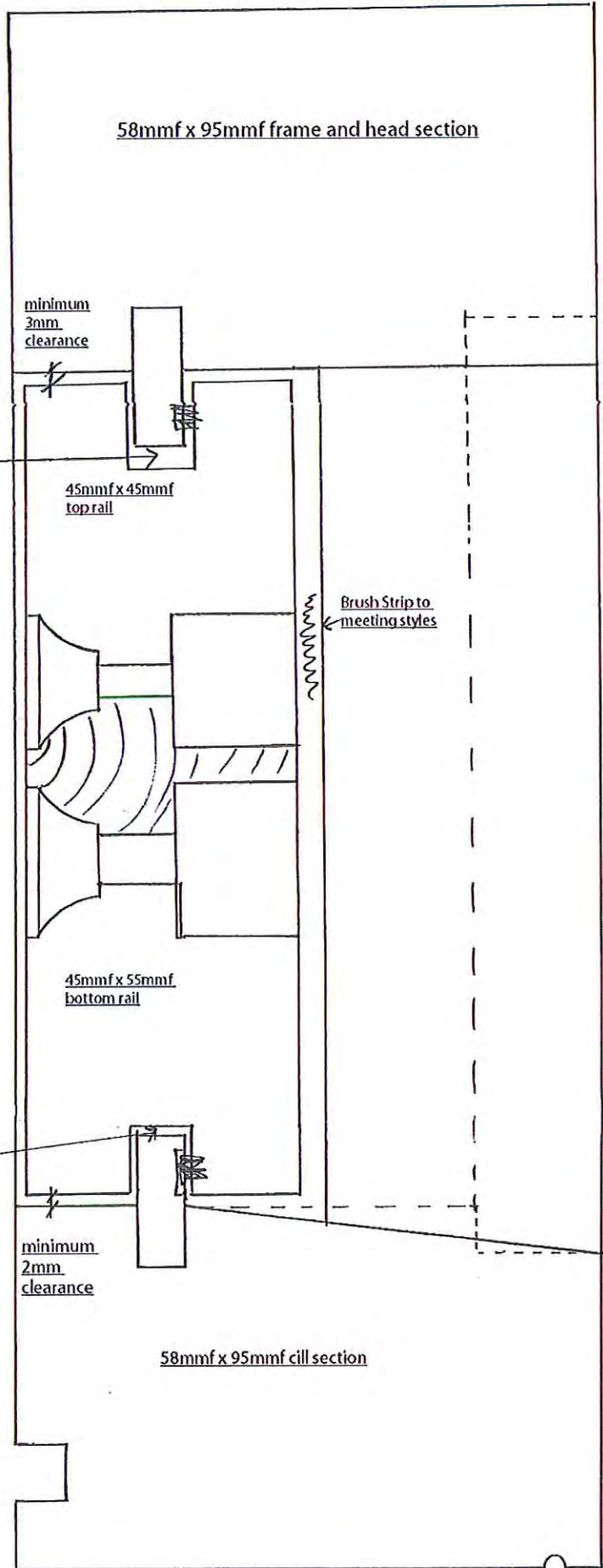

58mm x 95mm frame and head section

minimum
3mm
clearance

clearance to allow for
expansion of sash

45mm x 45mm
top rail

Brush Strip to
meeting styles

45mm x 55mm
bottom rail

sash sits on runner
not on cill base

minimum
2mm
clearance

58mm x 95mm cill section

rebate and bevell finish at the same point
on the face of the frame

NYMNP
16 JUN 2017



NYMNP
16 JUN 2017

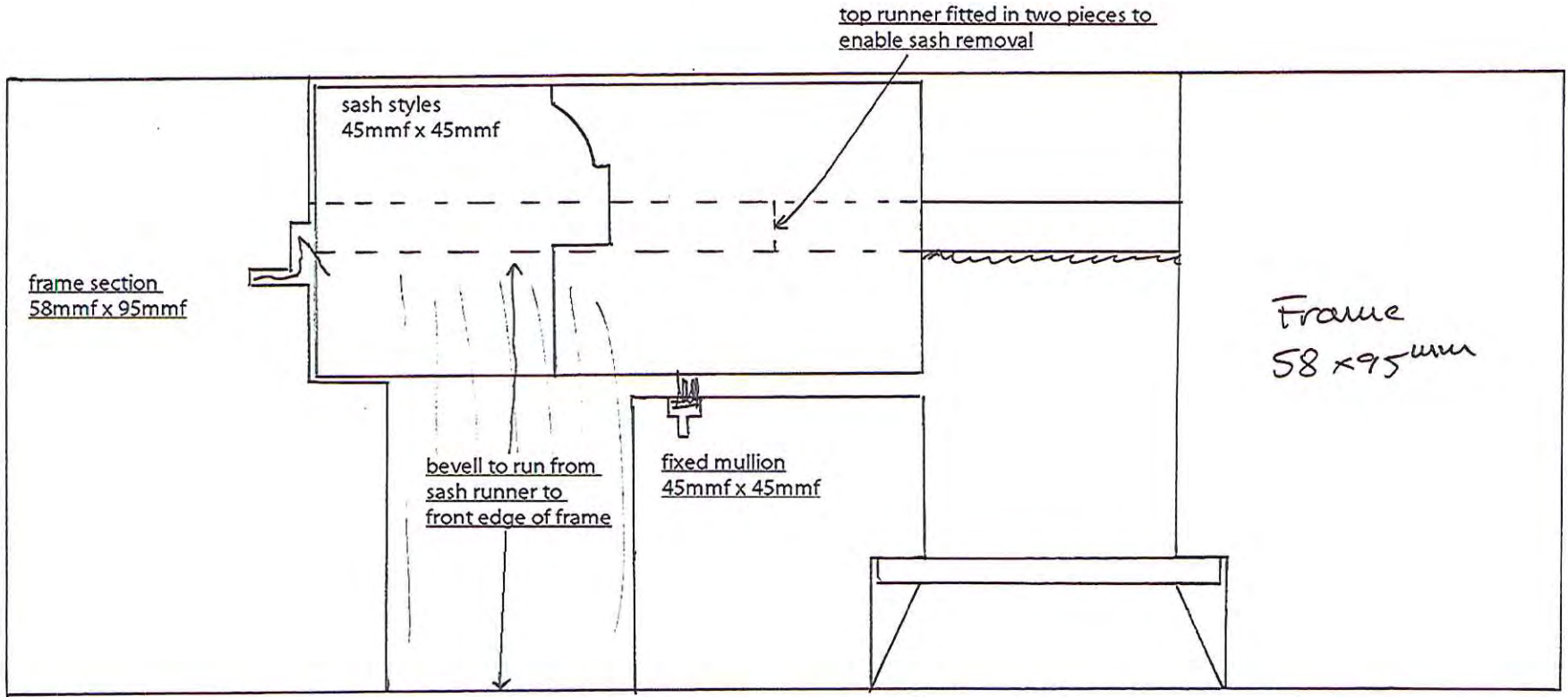

Frame
58 x 95mm

external side

NYMNPA
16 JUN 2017