



**Project Management Plan
(Construction Phase Plan)**

Contractor:
ASSOCIATED MINING CONSTRUCTION UK

Client: Sirius Minerals PLC

AMC UK Contract Number: RPA-127

Scheme: Phase 4 – Diaphragm Wall Construction

Document Number:
40-AMC-WS-71-PM-PL-0003

Head Office Address

Associated Mining
Construction UK
c/o Sirius Minerals
7-10 Manor Court
Manor Garth
Scarborough
YO11 3TU

**TEL
No**

**FAX
No**

Project Address

AMC UK Site Office
Woodsmith Mine
(Off B1416)
Sneatonthorpe
North Yorkshire
YO22 5HZ

Telephone

Designer Address

Associated Mining
Construction UK
c/o Deilmann-Haniel
GmbH
Haustenbecke 1
44319
Dortmund

**Designer Phone
Number**

CONTRACTOR

Associated Mining
Construction UK

AMC UK STATUS

START

FINISH

Designer

Contractor

**July
2017**

**March
2018**

Yes

Yes

Drafted By

AMC UK

Accepted By

Sirius Minerals PLC

Name

Hugh Medcalf

Name

Terry Quaife

Date

26/05/17

Date

Signature

Signature

NORTH YORKSHIRE POLYHALITE PROJECT

Phase 4 – PMP Diaphragm Wall Construction

Document Number: 40-AMC-WS-71-PM-PL-0003

1. Contractor Document Submittal History:

Revision:	Date:	Prepared by:	Checked by:	Approved by:	Reason for Issue:
A	21/04/17	HM	SF		Internal Review
0	16/05/17	HM	SF	JW	Issued to Sirlus for Comment
0A	23/05/17	HM	SF	JW	Issued to Sirius for Comment
1	26/05/17				Issued for Use

2a. External Peer Review Required?

YES NO

Peer Review required: Purpose of submission For approval
 For information
 Other: _____

This document has been reviewed by the following individual for coordination, compliance, integration and acceptance and is acceptable for transmission to the above stakeholder for the above stated purpose.

Sign: _____ Role: _____ Name: _____ Date: _____

Sign: _____ Role: _____ Name: _____ Date: _____

2b. Review by External Peer (if required):

Reviewer Organisation	Job Title	Name	Signature	Date	Acceptance
					<input type="checkbox"/>

3. Acceptance by Sirius Minerals:

Sirius Minerals Review and Acceptance			
This is to be used for submitted documents requiring acceptance by <i>Sirius Minerals</i> .			
<input type="checkbox"/>	Code 1.	Accepted. Work May Proceed	
<input type="checkbox"/>	Code 2.	Not Accepted. Revise and resubmit. Work may proceed subject to incorporation of changes indicated	
<input type="checkbox"/>	Code 3.	Not Accepted. Revise and resubmit. Work may not proceed	
<input type="checkbox"/>	Code 4.	Received for information only. Receipt is confirmed	
Reviewed/Accepted by:(signature)	Print Name:	Position:	Date:
<p>Acceptance by <i>Sirius Minerals</i> does not relieve the designer/supplier from full compliance with their contractual obligations and does not constitute <i>Sirius Minerals</i> approval of design, details, calculations, analyses, test methods or materials developed or selected by the designer/supplier.</p>			

REVISION SHEET

Report title	Phase 4 – PMP Diaphragm Wall Construction				
Document number	40-AMC-WS-71-PM-PL-0003				
Rev.	Revision description	Prepared by	Checked by	Approved by	Rev. Date
A	Internal Review – Edits to whole document	Hugh Medcalf	Steve Farrell		21/04/17
0	Issued to Sirius for Comment	Hugh Medcalf	Steve Farrell	Jonathan White	16/05/17
0A	Issued to Sirius for Comment	Hugh Medcalf	Steve Farrell	Jonathan White	23/05/17
1	Issued for Use	Hugh Medcalf	Steve Farrell	Jürgen Franz	26/05/17

Table of Contents

Section 1 – Project Description and Details	7
1.1. Description of the Project	7
1.1.1. Project Overview	7
1.1.2. Description of Phase 4 Construction Works	7
1.1.3. Supporting Documentation	7
1.1.4. Programme	7
1.2. Project Objective and Goals	7
Section 2 – Project delivery	9
2.1. Standard Setting	9
2.2. Project Structure.....	9
2.2.1. Project Organisational Chart.....	9
2.2.2. Client, Designer, Contractor and Sub-contractors.....	9
2.2.3. Key Contact Details	10
2.3. AMC UK Management Team - Roles and Responsibilities	11
2.3.1. AMC UK Management - Responsibilities.....	12
2.4. Quality, Environment, Health and Safety (QESH) Performance	13
2.4.1. Project QESH Objectives and Targets	13
2.4.2. Arrangements for Monitoring Quality, Environment, Health and Safety (QESH) Performance	13
Section 3 - Quality Management	14
3.1. Quality Management.....	14
3.1.1. Document Control	14
3.1.2. Existing Plans/Records	14
3.1.3. Human Resources	14
3.1.4. Procurement	14
3.1.4.1. Selection and Control of Suppliers and Subcontractors	15
3.1.5. Provision of Services	15
3.1.6. Provision of Plant and Materials	15
3.1.6.1. Product Identification and Traceability	15
3.1.6.2. Verification on Receipt	15
3.1.6.3. Handling, Storage, Packaging and Preservation	16
3.1.7. Client Property	16
3.1.8. Laboratory Testing	16
3.1.9. Non-Conforming Products/Services	16
3.1.10. Client Satisfaction	17
3.1.11. Audits, Inspections and Reports	17
3.1.12. Continuous Improvement.....	17
Section 4 - Client Specific Requirements	18
Section 5 - Gathering/Collection/Storage of Records and Information.....	18
Section 6 - Contract Filing.....	18
Section 7 - Health and Safety	18
7.1. Health and Safety Documentation	18
7.1.1. Health and Safety Legislation	18
7.2. Health and Safety Goals.....	19
7.2.1. Health and Safety – Company Life Saving Rules.....	19
7.3. Implementation of Health and Safety Plan	20
7.3.1. Organizational Chart.....	20
7.3.2. Health and Safety Responsibilities	20
7.3.2.1. Client.....	20
7.3.2.2. Client’s Project Manager.....	20
7.3.2.3. Designer(s).....	21
7.3.2.4. AMC UK Management.....	21
7.3.2.5. AMC UK Package Manager.....	21
7.3.2.6. AMC UK Health & Safety Manager.....	21
7.3.2.7. AMC UK and Sub-contractor Site Supervisors	22

7.4. Communication of Health and Safety Issues	22
7.5. Management of Health & Safety on Site	22
7.6. AMC UK Policies	23
7.7. Safe Working Practices (SWPs)	23
7.8. Risk Assessments and Method Statements.....	23
7.8.1. Hazard Identification, Risk Assessment and Controls.....	23
7.8.2. Activity or Task Specific RAMS	24
7.8.3. Control of Substances Hazardous to Health	24
7.9. Permit System.....	24
7.10. Field Level Risk Assessment.....	25
7.11. Job Observation Programme.....	25
7.12. Reporting/Investigation of Accidents, Incidents and Near Misses	25
7.13. Site Rules.....	25
7.13.1. Drug and Alcohol Policy.....	25
7.14. Emergency Procedures	25
7.14.1. First Aid.....	25
7.14.2. Fire	25
7.14.3. Damage of Underground Services	26
7.14.4. Liquid/Chemical Spills.....	26
7.15. Auditing and Reporting Performance	26
Section 8 - Environmental Management	26
8.1. Environmental Management Documentation.....	26
8.2. Environmental Permits/Consents and Constraints	27
8.3. Environmental – Golden Rules.....	27
8.4. Implementation of the Environmental Management Plan	28
8.4.1. Organizational Chart.....	28
8.4.2. Responsibilities	29
8.4.2.1. Client.....	29
8.4.2.2. Client’s Project Manager.....	29
8.4.2.3. AMC UK Package Manager(s).....	29
8.4.2.4. AMC UK Environmental Manager	30
8.4.2.5. AMC UK Site Environmental Co-ordinator	30
8.4.2.6. AMC UK Environmental Inspector	30
8.4.3. Communication of Environmental Issues	31
8.4.3.1. Site Inductions and Toolbox Talks.....	31
8.4.3.2. Communication with Site Staff.....	31
8.4.3.3. Communication within the Contractor’s Environmental Team	31
8.5. Management of Environmental Issues on Site	31
8.5.1. Supervision of Construction Activities.....	31
8.5.2. Monitoring Environmental Impacts during Construction	31
8.5.3. Environmental Studies and Surveys.....	31
8.5.4. Protected Species and Precautionary Method of Working	31
8.5.5. Environmental Monitoring and Measurement.....	32
8.5.6. Environmentally Significant Changes	32
8.5.7. Environment and Sustainability	32
8.5.8. Site Waste Management Plan (SWMP).....	32
8.5.9. Considerations With Respect to Air	32
8.5.10. Considerations With Respect to Land and Water.....	32
8.5.10.1. Silt and Surface Water Management.....	32
8.5.11. Considerations with Respect to Noise and Vibration.....	32
8.5.12. Archaeology and the Built Heritage	33
8.5.13. Plant and Wheel Wash Arrangements.....	33
8.5.14. Slurry Loss to Permeable Geological Units	33
8.5.15. Light Pollution	33
8.5.16. Carbon Reduction and Energy Management	33
8.5.17. Environmental Aspects and Impacts Assessment.....	34
8.5.18. Control of Substances Hazardous to the Environment.....	34

8.5.18.1.	Fuel	34
8.5.18.2.	Chemicals.....	34
8.5.18.3.	Bentonite Slurry.....	34
8.5.19.	Environmental Incidents and Near Misses	35
8.6.	Auditing and Controlling Environmental Performance.....	35
8.6.1.	Reporting Environmental Performance.....	35
Section 9 - Project Communications.....		36
9.1. Project Communications		36
9.1.1.	Regular Liaison between Parties	36
9.1.2.	Complaints Procedure	36
9.2. Internal Consultation Process.....		37
9.2.1.	Consultation with the Workforce	38
9.2.2.	Communication with Sub-Contractors	39
9.2.3.	The Exchange of Design Information	39
9.2.4.	Managing Design Changes	39
Section 10 - Site Controls.....		40
10.1. Site Security		40
10.1.1.	Site Fencing	41
10.2. Site Visitors		41
10.3. Site Induction, Information and Training.....		41
10.3.1.	On-Site Training.....	41
10.4. Provision of Welfare Facilities		41
10.4.1.	Site Notice Boards	41
10.4.2.	Illustrated Mandatory and Advisory Health & Safety Information to be Displayed On-site	42
10.4.3.	Illustrated Mandatory and Advisory Environmental Information to be Displayed On-site	42
10.4.4.	Emergency Procedures	42
10.4.5.	Deliveries and Logistics	43
10.4.5.1.	Delivery Routes.....	43
10.4.5.2.	Penalty System for Breaches of Traffic Management Requirements	43

Appendix A – Design Drawings

Appendix B – Environmental Management Plan (EMP)

SECTION 1 – PROJECT DESCRIPTION AND DETAILS

This Project Management Plan (PMP) document provides a summary of how the Phase 4 construction activities at the Woodsmith Mine Site will be managed, executed, monitored and controlled. Details of the exact construction works to be completed under Phase 4 are defined in the Phase 4 design documentation (selected design drawings are provided in Appendix A).

1.1. Description of the Project

1.1.1. Project Overview

Sirius Minerals PLC is in the process of constructing a new mine development site south of Whitby in North Yorkshire to extract and process polyhalite and transfer it to a processing and harbour facility on Teesside (the harbour facility is covered by a separate consenting regime). A full and detailed description of the project can be found in the Environmental Statement (as updated).

1.1.2. Description of Phase 4 Construction Works

This PMP is intended to cover the Phase 4 construction activities only, which include the following key tasks:

- Operation of the concrete batch plant;
- Installation, commissioning and operation of the bentonite plant and associated temporary structures;
- Installation of concrete guide walls (excavate to -3.5m and concrete wall down to -1.5 to -1.75 m);
- Mobilisation to site of diaphragm walling equipment (cutters, cranes, workshops etc.); and
- Diaphragm wall construction to -60m below ground level at the Production, Service and Mineral Transport System shafts.

Site Layout for Phase 4 construction activities is shown on Drawing 40-ARI-WS-71-CI-DR-1081 in Appendix A.

1.1.3. Supporting Documentation

This PMP should be read in conjunction with the following Phase 4 documents:

- Construction Environment Management Plan (CEMP);
- Environmental Management Plan (EMP) – *AMC UK Environmental Management Plan (EMP) Woodsmith Mine Phase 4 – Diaphragm Wall Construction* (Reference 40-AMC-WS-71-EN-PL-0004) appended to this document.
- Environmental Emergency Preparedness Plan – *AMC UK Environmental Emergency Preparedness Plan (EEMP) Woodsmith Mine Site - Phase 4 – Diaphragm Wall Construction* (Reference 40-AMC-WS-71-EN-PL-0005, appended to EMP);
- Site Waste Management Plan – *AMC UK Site Waste Management Plan (SWMP) Woodsmith Mine Site - Phase 4 – Diaphragm Wall Construction* (Reference 40-AMC-WS-71-EN-PL-0006, appended to EMP).
- Project Quality Plan (PQP) – *AMC UK Project Quality Plan* (Reference 40-AMC-WS-71-EN-PL-0004).
- Construction Phase Health and Safety Plan (CPHSP) – *AMC UK Construction Phase Health and Safety Plan (CPHSP) Woodsmith Mine Phase 4 – Diaphragm Wall Construction* (Reference 40-AMC-WS-71-PM-PL-0002).
- Emergency Response Plan *AMC UK Emergency Response Plan (ERP) Woodsmith Mine Phase 4 – Diaphragm Wall Construction* (Reference 40-AMC-WS-71-HS-PL-0003).

1.1.4. Programme

The proposed start date for Phase 4 Construction activities is July 2017 with the works anticipated to be completed in March 2018.

1.2. Project Objective and Goals

It is AMC UK's objective to carry out the Phase 4 construction works in such a way as to give due regard to the welfare of all persons involved in carrying out the works, and without putting their health and safety at significant risk, along with that of others who may be affected by the works, including members of the general public and visitors to

the site of the works. The works will also be managed in such a way to minimise any potential impacts to the environment.

The overall project goals in relation to Quality, Health & Safety and Environment are outlined below:

The **Quality** goals are to:

- Meet or exceed the client's requirements;
- Comply with project drawings and other written specifications;
- Report all non-conformances; and
- Comply with product/process legislation.

The **Health and Safety** goals are to:

- Achieve zero RIDDOR (Reporting of Injuries, Diseases and Dangerous Occurrences Regulations 2013) and accidents;
- Prevent or minimise the number of non-RIDDOR accidents and incidents;
- Comply with project H&S requirements;
- Report all accidents, incidents and near misses; and
- Comply with current health and safety legislation.

The **Environmental** goals are to:

- Prevent or minimise any environmental disturbance;
- Comply with project environmental requirements;
- Report all incidents and near misses; and
- Comply with environmental legislation.

SECTION 2 – PROJECT DELIVERY

2.1. Standard Setting

Through management supervision and monitoring, AMC UK will ensure that works carried out as part of the Phase 4 construction activities is undertaken in accordance with relevant procedures, policies, Legislation, Approved Codes of Practice and Guidance Notes.

The company will operate under the controls defined in the Construction Phase Health and Safety Plan (CPHSP), an Environmental Management Plan (EMP) and the Project Quality Plan (PQP).

2.2. Project Structure

2.2.1. Project Organisational Chart

The following outlines the organisational chart for the project.

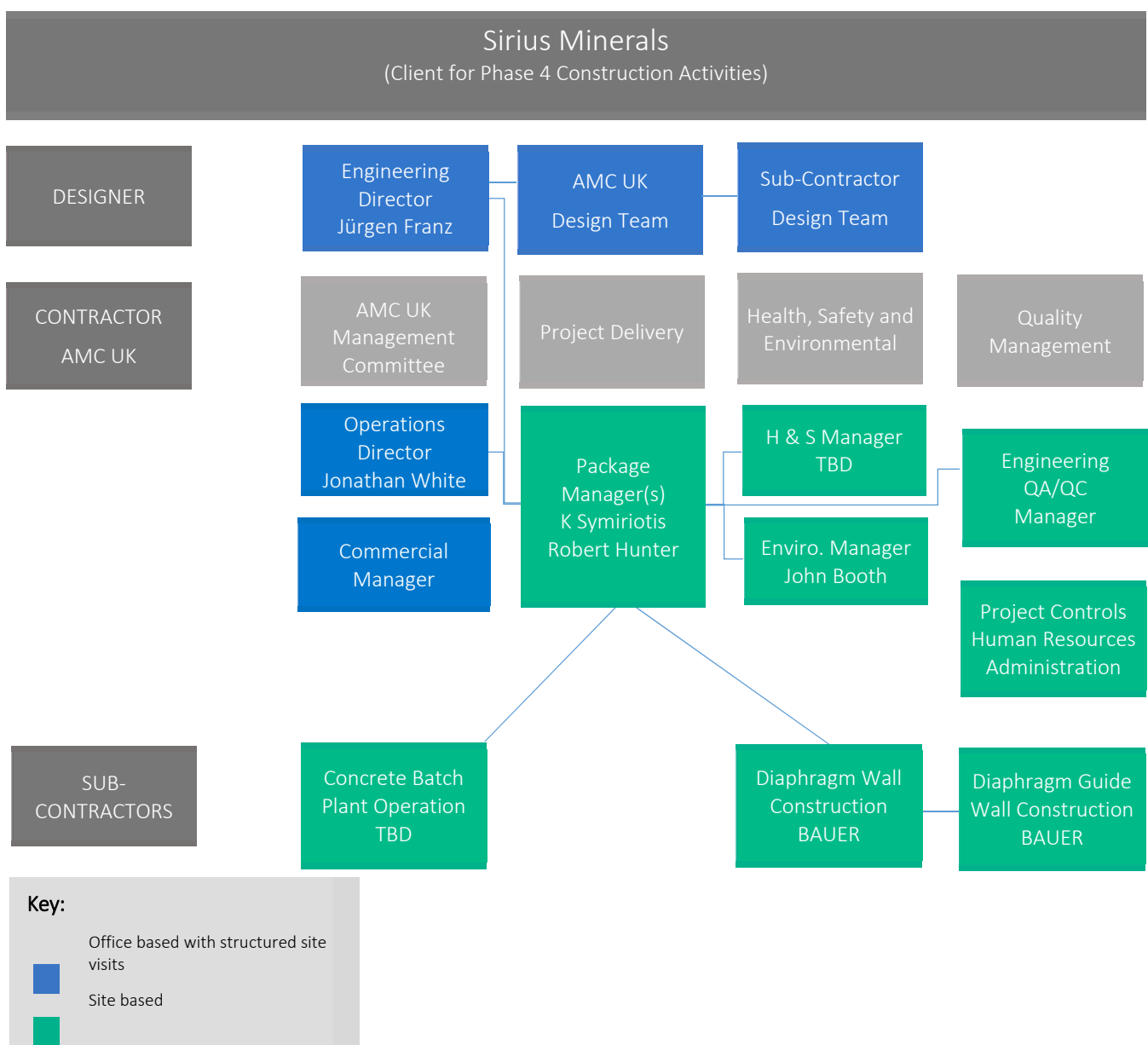

2.2.2. Client, Designer, Contractor and Sub-contractors

Role	Duty Holder	Contact Details
CLIENT	Sirius Minerals PLC	Name: Terry Quaife Position: Area Manager Shafts
DESIGNER	ASSOCIATED MINING CONSTRUCTION UK c/o Deilmann-Haniel GmbH Haustenbecke 1 44319 Dortmund	Name: Jürgen Franz Position: Engineering Director
CONTRACTOR	ASSOCIATED MINING CONSTRUCTION UK	Name: Jonathan White Position: Operations Director
Sub-Contractors	Bauer Technologies TBD	Diaphragm Wall Construction Operation of Concrete Batching Plant

2.2.3. Key Contact Details

Sirius Minerals (Client)

Contact Name and Position	TEL NO.
Robert Staniland, Environment Manager	
William Woods, Project Development Manager	
Terry Quaife, Area Manager Shafts	
John Price, Construction Manager	
Gary Ward, HSE Advisor	

AMC UK (Main Contractor)

Contact Name and Position	TEL NO.
Andrea Whitingham, Head Office	
Jonathan White Operations Director	
Lee Williamson, Commercial Manager	
Robert Hunter, Package Manager – Diaphragm Wall Construction	TBD
Konstantinos Symiriotis, Package Manager – Concrete Batch Plant Operation	
Jürgen Franz, Engineering	
TBD, Health and Safety Manager	TBD
John Booth, Environmental Manager	
Hugh Medcalf, HSE Advisor	
Clive Dowdeswell, Logistics Manager	
TBD, Quality Manager	TBD

Statutory Undertakers – Emergency Telephone Numbers

Service	TEL NO.
Gas, National Grid	
Water Services, Yorkshire Water	
Electricity, Northern Power Grid	
Oil or Gas Pipeline (British Pipeline Agency)	
Telephone, BT	
Cable, Virgin Media	
Sewerage Services, Yorkshire Water	

Service	TEL NO.
Environment Agency	
Health and Safety Executive	
Local Police Station	
North Yorkshire County Council (Pam Johnson)	
North York Moors National Park Authority (Mark Hill)	

2.3. AMC UK Management Team - Roles and Responsibilities

Name	Position	Phase 4 Activity	RESPONSIBILITIES (in brief)
Jonathan White	Operations Director	All aspects	Overall responsibility for the projects safety, health and environmental management. Responsibility for resources, implementation of procedures and provision of time/resources to support to meet the arrangements documented in this plan.
Jürgen Franz	Principal Designer (Engineering Director)	All aspects	Overall design authority
Bauer Technologies	Designer	Diaphragm Wall	Design and construction of diaphragm walls at the Production, Service and MTS shafts.
Liebherr	Designer	Concrete Batching Plant	Design, supply and commission a concrete batching plant.
Robert Hunter Konstantinos Symiriotis	Package Manager(s)	Diaphragm Wall Concrete Batching Plant Operations	Control and manage on site construction activities, manage sub-contract activities on site, ensure client satisfaction throughout construction process and implement best practise regarding QESH procedures.
TBD	Health and Safety Manager	All aspects	Advise, support and monitor health and safety policies and procedures documented in this plan and current legislation.
John Booth	Environmental Manager	All aspects	Advise, support and monitor environmental management policies and procedures documented in this plan and current legislation.
TBD	Quality Manager	All aspects	Advise, support and monitor environmental management policies and procedures

The following table outlines the key project responsibilities and provides roles to specific project members.

2.3.1.AMC UK Management - Responsibilities

Responsibility	Nominated person	Role (In order of Seniority)	Coordinators											Controllers										
			Project Management Plan	Legal Requirements	Environment Aspects and Impacts	Risk Assessment and Method Statements	Document Control and record Keeping	Emergency Preparedness and Response Plans	Waste Management (SWMP)	Monitoring and Measurement	Accidents, Incidents and near miss Reporting and	Non-conformances, Corrective and Preventive	Procurement	Temporary Works coordinator	Water Permits Control and Samolina	Site Safety	Control of Substances Hazardous to Health	Permits to work	Lifting Operations	Site Inductions and Briefings	Fire Coordinator / Marshals	Plant Records	First aiders	Site Security
	Jonathan White	Operations Director	X	X			X																	
	Konstantinos Symiriotis Robert Hunter	Package Manager(s)	X	X	X	X	X	X	X	X	X	X	X		X	X	X	X	X	X	X			X
	Jürgen Franz	Engineering	X			X	X			X		X									X			
	TBD	Health and Safety Manager				X	X	X		X	X			X		X	X	X	X	X	X	X	X	X
	John Booth	Environmental Manager			X		X	X	X	X			X			X			X					
	TBD	Quality Manager	X	X			X			X		X						X			X			
	Lee Goodlad	Project Scheduler	X				X																	
	TBD, Concrete Batch Plant	Sub-Contractor(s)				X		X	X	X	X		X		X	X	X	X	X	X	X	X	X	X
	Bauer Site Supervisor	Sub-Contractor(s)				X		X	X	X	X		X		X	X	X	X	X	X	X	X	X	X

2.4. Quality, Environment, Health and Safety (QESH) Performance

2.4.1. Project QESH Objectives and Targets

Quality, Environmental and Health and Safety (QESH) and client objectives and targets are set out below, along with the arrangements for monitoring and review of performance.

OBJECTIVE	TARGET	MEASURE	REVIEW PROCESS	OWNER
Environmental objective/targets	Zero environmental incidents	Contractor's Report	Monthly	Project Manager
	My Brother's Keeper reporting	Contractor's Report	Monthly	Project Manager
Quality objectives/targets	Zero defects at handover	Defects list at handover	Review at handover	Project Manager
Health and Safety objectives/targets	Zero accidents	Contractor's Report	Monthly	Project Manager
	My Brother's Keeper reporting	Contractor's Report	Monthly	Project Manager

2.4.2. Arrangements for Monitoring Quality, Environment, Health and Safety (QESH) Performance

During the Phase 4 construction activities, AMC UK will be responsible for ensuring that its quality, environment and health and safety performance and the performance of its subcontractors are reviewed on an ongoing basis. Members of the management team (as defined in Section 2.3) will monitor performance through regular audits and inspections. The frequency of the inspections and audits in relation to quality, environmental and health and safety matters are contained within the relevant management plans and summarised below.

Performance will be reviewed at each Project Review Meeting attended by all relevant members of the Project.

Any issues identified will be raised immediately with the relevant party, who will be expected to implement the appropriate corrective action within timescales agreed between both parties.

QEHS	Inspection/Audit	Completed By	Frequency
Quality	Routine inspection of quality system	QM	Daily
	Formal Quality Performance Audit	QM	Monthly
Environment	Inductions/Daily Meeting/Toolbox Talks	PM / SS	Daily / As Required
	Supervision of EMP Performance On-site	PM / SS	Daily
	EMP Performance Review & Attend AMC UK Environmental Meeting	EM / PM / SS	Weekly
	Monthly progress meeting and reporting	EM / PM / SS / Client	Monthly
	Completion of EMP Checklists	SS	Daily
	Collection of Waste Management Records	SS	Daily
	Collate COSHH Inventory	EM	Commencement of works and as required
	Management Audit of EMP Performance	EM / PM / AMC Management	Quarterly
	Emergency Preparedness Exercise	EM / PM / SS / Workforce	Yearly
Health & Safety	Inductions/Daily Meeting/Toolbox Talks	PM / SS	Daily / As Required
	Routine H&S Inspections	HS / SS	Daily
	H&S Performance Review & Attend AMC UK Health & Safety Meeting	HS / PM / SS	Weekly
	Monthly progress meeting	HS / PM / SS / Client	Monthly
	Representative H&S Meeting	HS / PM / H&S Reps	3 months

QEHS	Inspection/Audit	Completed By	Frequency
	Issuance and inspection of Permits to Work	PM / SS	As Required
	Completion of H&S System (forms, checklists etc)	SS	Daily
	Management Audit of H&S Performance	HS / PM / AMC Management	Quarterly
	Emergency Preparedness Exercise	EM / PM / SS / Workforce	Yearly

PM – Package Manager
 SS – Site Supervisor
 QM – Quality Manager
 HS – Health and Safety Manager
 EM – Environmental Manager

SECTION 3 - QUALITY MANAGEMENT

3.1. Quality Management

Quality management within the project will be completed in accordance with the Project Quality Plan and relevant policies.

3.1.1. Document Control

All documents relating to the contract, whether electronic or hard copy will be processed in accordance with the AMC UK Document Control Procedure. The document numbering system will reflect the numbering system defined in the Sirius Minerals *Document Numbering Procedure* (Reference 40-SMP-GE-00-AD-PR-0001).

All completed site records shall be generated and maintained on-site in accordance with the AMC UK Document Control Procedure, with electronic copies retained in the AMC UK Head Office. Copies of redundant documents will be retained in the Environment and Health & Safety files to show the progressive revisions status of each document (superseded documents will be clearly marked “S/S” when retained for legal and/or knowledge preservation purposes).

Incoming project and contract documents will be date stamped and annotated with the contract number and status prior to copies being distributed to the relevant parties.

3.1.2. Existing Plans/Records

Records and Information	Format	Provided by
ECl Scope of Works	Documents	Sirius Minerals
Key Deliverables agreed with client	Documents	Sirius Minerals
Project Risk Register	Documents	AMC UK
Buried services plans	Electronic and colour print	Arup
Health, Safety and Environmental Files	Documents	AMC UK

3.1.3. Human Resources

AMC UK is an equal opportunity employer and complies with all current statutory legislation. All Human Resource activities are to take place in accordance with the relevant company policies and procedures relevant to the hiring, training and management of the workforce.

Personnel shall be employed based upon their competence, education and experience. Training will be provided where identified as being required or in the event of the introduction of new process and/or working practices where training/awareness is considered necessary by the relevant Package Manager or Operations Director.

3.1.4. Procurement

All procurement on this contract shall be undertaken in accordance with AMC UK procurement procedures and policies.

In accordance with the Health and Safety at Work Etc. Act 1974, all orders shall contain the statement that any article or substance to be supplied is, so far as is reasonably practicable, safe and without risk to health whilst being prepared for use, used, cleaned or maintained. Any tests or examinations and full instructions for the safe use etc. shall be provided and any information supplied on any adverse effects upon the environment.

3.1.4.1. Selection and Control of Suppliers and Subcontractors

All suppliers and subcontractors are subject to the AMC UK supplier and sub-contractor selection procedures. Only suppliers and subcontractors on the AMC UK preferred suppliers list will be used on this project. These have successfully completed and met the minimum requirements of the selection procedure. The suppliers or subcontractors performance will be monitored by the management team. If they fail to meet the minimum requirements documented within this plan, supporting policies, procedures and processes they will be instructed to improve or be removed from the contract.

Opportunities will be given to local suppliers by considering technical capabilities, price, delivery schedule, and ease of QA/QC surveillance. If all elements are equal, local suppliers will be preferred.

3.1.5. Provision of Services

All services will be provided by suitably trained and experienced personnel in accordance with the contract with AMC UK. These personnel are to adhere to AMC UK procedures and policies during the delivery of their works. It is assumed that in performing the services, the Contractor or Consultant shall exercise all the reasonable skill, care and diligence to be expected of an appropriately qualified and competent contractor or consultant experienced in carrying out equivalent services for projects of a similar size, scope, complexity, value and purpose.

3.1.6. Provision of Plant and Materials

3.1.6.1. Product Identification and Traceability

Identification is originally established by the accompanying documentation (i.e. delivery ticket, or product marking). Identification is maintained only for materials or product to be retained in permanent or temporary storage areas and is at the discretion of the contract Management.

The methods of maintaining identification, as appropriate to the products/materials, include the following:

- Segregation by location.
- Existing labelling or product marking.
- Attaching labels if necessary.
- Grouping of components.
- Shelf life of items, where appropriate (first in / first out).

The Control of Substances Hazardous to Health (COSHH) risk assessment will identify any purchased materials or products hazardous to health and to the environment and the Package Manager shall implement appropriate identification and control measures for handling, storage and traceability.

3.1.6.2. Verification on Receipt

The following procedure will be followed by the contract management for all deliveries to this site:

The person receiving products/materials, whether purchased or Client supplied shall:

- Compare supplier delivery note against pertinent copy purchase order.
- Determine if goods conform to delivery note.
- Visually examine goods for any obvious signs of transit damage, contamination or deterioration.
- Quantity checks where appropriate.
- Identify "Use by date" of items, where appropriate (check with manufacturer if unsure).

Records of verification will be established by endorsing the delivery ticket as follows:

- Date of receipt (if not pre-printed on the ticket on day of receipt).
- Signature and printed name of person receiving the goods.
- Comments as to acceptability of products as appropriate.

Any problems are recorded against the supplier using the non-conformance system which is part of the supplier review process.

3.1.6.3. Handling, Storage, Packaging and Preservation

All materials shall be handled in such a manner as to prevent damage, pollution or injury. Materials containing a substance hazardous to health are handled in accordance with the specific COSHH Assessment (refer to Safe Working Practice document SWP 014, appended to CPHSP).

Materials will be stored in a manner and location to prevent damage, pollution or deterioration. For materials being temporarily stored on site prior to use, packaging will only be removed to enable product verification at time of delivery. Packaging shall be ultimately disposed of in a controlled manner, either back to the supplier or in the appropriate waste receptacles.

Items with a defined shelf life shall be used on a first in / first out basis to avoid creating waste from unused, out of date stocks.

Packaging and protection to materials with sensitive finishes shall remain on the goods until handed over to the Client. Alternatively, adequate additional protection may be applied after incorporation into the contract works, to comply with Client specifications, if applicable, until handover to, or takeover by, the Client. Removal of protection material shall only be undertaken with the approval of the Client, upon handover to, or takeover by, the Client.

3.1.7. Client Property

AMC UK shall execute care with Client property (including intellectual property) whilst it is under our care. All Client property shall be identified and protected. If any Client property is damaged, lost or otherwise found to be unsuitable for use then this must be reported to the Client and a non-conformance logged.

All data and information provided by customers is treated as confidential in accordance with the requirements of the Data Protection Act 1998 and is protected using suitable physical and electronic protection methods.

3.1.8. Laboratory Testing

Testing will be undertaken in accordance with the design specification. Laboratory testing will be undertaken by a certified third party laboratory with independent quality control testing being undertaken as required in the design specification.

3.1.9. Non-Conforming Products/Services

In the instances of non-conforming products or undesirable/unplanned events, such as Client complaints etc. a Non-Conformance Note shall be raised to facilitate effective closeout in a timely manner and by identification of root-causes to minimise the risk of recurrence.

Non-conformances relating to subcontractors will be categorised in the following manner:

- Poor Records;
- Incorrect Delivery;
- Late Delivery not affecting Construction Programme;
- Poor Communication;
- Incorrect Invoicing;
- Minor Failure within Allowed Tolerances;
- Attitude of AMC UK Site;
- Health and Safety;
- Environmental;
- Product Failure requiring Rework/Cost;
- Works requiring Concession;
- Non-conformances highlighted by Client; and
- Late Delivery affecting Construction Programme.

Corrective action shall be undertaken on all significant issues as soon as reasonably practicable, all non-significant non-conformances shall be monitored and actioned as appropriate.

3.1.10. Client Satisfaction

On completion of a project, a contract performance questionnaire is to be given to the client to assess the level of workmanship delivered by our workforce. The completed form is then passed to the Operations Director for any actions to be taken. If a client has an alternative system then this should be used. Any complaints are dealt with as non-conformances.

3.1.11. Audits, Inspections and Reports

A Quality Audit programme is maintained by the Quality Manager ensuring that each section of the Quality Management System is verified at least annually.

More frequent Quality Audits may be organised by the Quality Manager depending on the importance of the activities being audited.

Internal Quality Audits are carried out according to the following procedures:

- At the beginning of each month, the Quality Manager consults the Quality Audit programme and establishes which, if any, parts of the Quality Management System are to be audited during the coming month.
- A member of staff, wherever possible independent of the activity to be audited, is appointed by the Quality Manager.
- The auditor refers to the Quality Manual and determines the activities to be audited.
- The auditor selects a representative number of records to be audited on a random basis.
- The auditor advises any personnel concerned that a Quality Audit is being undertaken and answers any questions they may have regarding the audit.
- The auditor examines the records selected in order to determine whether the activities identified above have been carried out correctly.
- The auditor keeps a record of the process and the findings of the Quality Audit.
- The Quality Audit record and all other documents relating to internal audits are passed to the Quality Manager.
- The Quality Audit record and all other documents relating to internal Quality Audits are retained for inspection by any client or other external stakeholders.

All issues arising from the internal Quality Audit requiring immediate attention are discussed with the appropriate personnel and a record kept. The Quality Manager ensures that the Quality Audit results are discussed at the next Management Review.

3.1.12. Continuous Improvement

The effectiveness of the Quality Management System is continually improved through the utilisation and application of the:

1. Quality Policy
2. Quality objectives
3. Quality Audit results
4. Analysis of data
5. Corrective and preventive actions
6. Management Review

A record will be kept on the Non-conformance Log of significant non-conformances (including complaints, audit findings, etc.), including details of the date and nature of non-conformance and the action taken.

The non-conformance is investigated to determine the cause of the problem and discussed with the member of staff responsible to prevent recurrence. New or revised procedures are developed as appropriate. Where appropriate, the Client is advised of the relevant factors causing the complaint or non-conformance (staff members to remain confidential) and the actions taken.

The collective actions taken to prevent recurrence of non-conformances, and those records and reports generated, are regularly reviewed at AMC UK Management Review Meetings to identify any trends and determine the effectiveness of the preventive measures taken.

SECTION 4 - CLIENT SPECIFIC REQUIREMENTS

Client requirements have been integrated into the AMC UK Project Quality Plan, the Construction Phase Health and Safety Plan and the Environmental Management Plan.

SECTION 5 - GATHERING/COLLECTION/STORAGE OF RECORDS AND INFORMATION

Records are to be maintained in accordance with the applicable policies and procedures (as defined in the Project Quality Plan).

SECTION 6 - CONTRACT FILING

Records specific to this contract are to be filed in accordance with the contract filing index. This may require the set-up of a number of folders in order to accommodate the records specified but the numbering system must be maintained in order to ensure that interested parties can locate the relevant documents easily.

SECTION 7 - HEALTH AND SAFETY

7.1. Health and Safety Documentation

The works will be undertaken in accordance with current Health and Safety legislation, with the site predominantly controlled under the *Mine Regulations 2014*.

Management of Health and Safety within the project will be completed in accordance with:

- Construction Phase Health and Safety Plan (CPHSP) – *AMC UK Construction Phase Health and Safety Plan (CPHSP) Woodsmith Mine Phase 4 – Diaphragm Wall Construction* (Reference 40-AMC-WS-71-PM-PL-0002).

For emergency situations, guidance is provided in:

- Emergency Response Plan *AMC UK Emergency Response Plan (ERP) Woodsmith Mine Phase 4 – Diaphragm Wall Construction* (Reference 40-AMC- WS-71-HS-PL-0003).

Activities identified as having significant safety risks or hazard not covered by the normal scope of works this will be documented and communicated via task specific Risk Assessments and Method Statements (RAMS) prepared by AMC UK or nominated sub-contractors.

7.1.1. Health and Safety Legislation

The following outlines the Health & Safety legislation relevant to the construction works:

- Mine Regulations 2014
- Health and Safety at Work Act 1974
- Management of Health and Safety at Work Regulations 1999
- Regulatory Reform (Fire Safety) Order 2005 (RRFSO)
- Dangerous Substances and Explosive Atmospheres Regulations 2002 (DSEAR)
- The Carriage of Dangerous Goods and Use of Transportable Pressure Equipment Regulations 2009 and ADR 2015
- Classification, Labelling and Packaging Regulations 2015 (CLP)
- Control of Substances Hazardous to Health Regulations 2002 (COSHH)
- Control of Asbestos Regulations 2012 (CAR)
- Work at Height Regulations 2005
- Control of Noise at Work Regulations 2005
- Control of Vibration at Work Regulations 2005
- Provision and Use of Work Equipment Regulations 1998 (PUWER)
- Lifting Operations and Lifting Equipment Regulations 2002 (LOLER)
- Pressure Systems Safety Regulations 1998 (PSSR)
- Construction (Design and Management) Regulations 2015
- Reporting of Injuries, Diseases and Dangerous Occurrences Regulations 2013 (RIDDOR)
- Personal Protective Equipment Regulations 2002 (PPE)

- Workplace (Health, Safety and Welfare) Regulations 1992
- Health and Safety (First-aid) Regulations 1981
- Health and Safety (Consultation with Employees) Regulations 1996
- Health and Safety (Signs and Signals) Regulations 1996
- Safety Representatives and Safety Committees Regulations 1977
- Electricity at Work Regulations 1989
- Manual Handling Operations Regulations 1992 (MHOR)
- Working Time Directive

7.2. Health and Safety Goals

The overall Health & Safety goals for the project are as follows:

- Achieve Zero RIDDOR (Reporting of Injuries, Diseases and Dangerous Occurrences Regulations 2013) and accidents;
- Prevent or minimise the number of non-RIDDOR accidents and incidents;
- Comply with project H&S requirements;
- Report all accidents, incidents and near misses; and
- Comply with Health & Safety legislation.

7.2.1. Health and Safety – Company Life Saving Rules

1. Never use or be under the influence of Drugs or Alcohol at work.
2. Never remove another person's personal lock or a person's underground access tag.
3. Never work or travel under a suspended load (surface works); or in, or under, unsupported ground.
4. Never move or operate machinery or equipment without the appropriate training and authorization.
5. Never tamper with or make a safety device inoperable.
6. Always follow project isolation procedures before working on equipment or where there may be an energy source.
7. Never enter an area that has access prohibiting barricades or signs – without authorization.
8. Never work at height above the sites prescribed distance, this includes from open holes without suitable fall protection.
9. Always comply with explosives, blasting and re-entry procedures.
10. Never operate heavy equipment within 10 meters of any pedestrians without first establishing and then maintaining positive contact and never approach mining equipment within 10 metres without positive contact.

7.3. Implementation of Health and Safety Plan

The management of health and safety is outlined in the Construction Phase Health and Safety Plan (CPHSP).

7.3.1. Organizational Chart

The following organizational chart shows the key personnel responsible for implementing the Construction Phase Health and Safety Plan

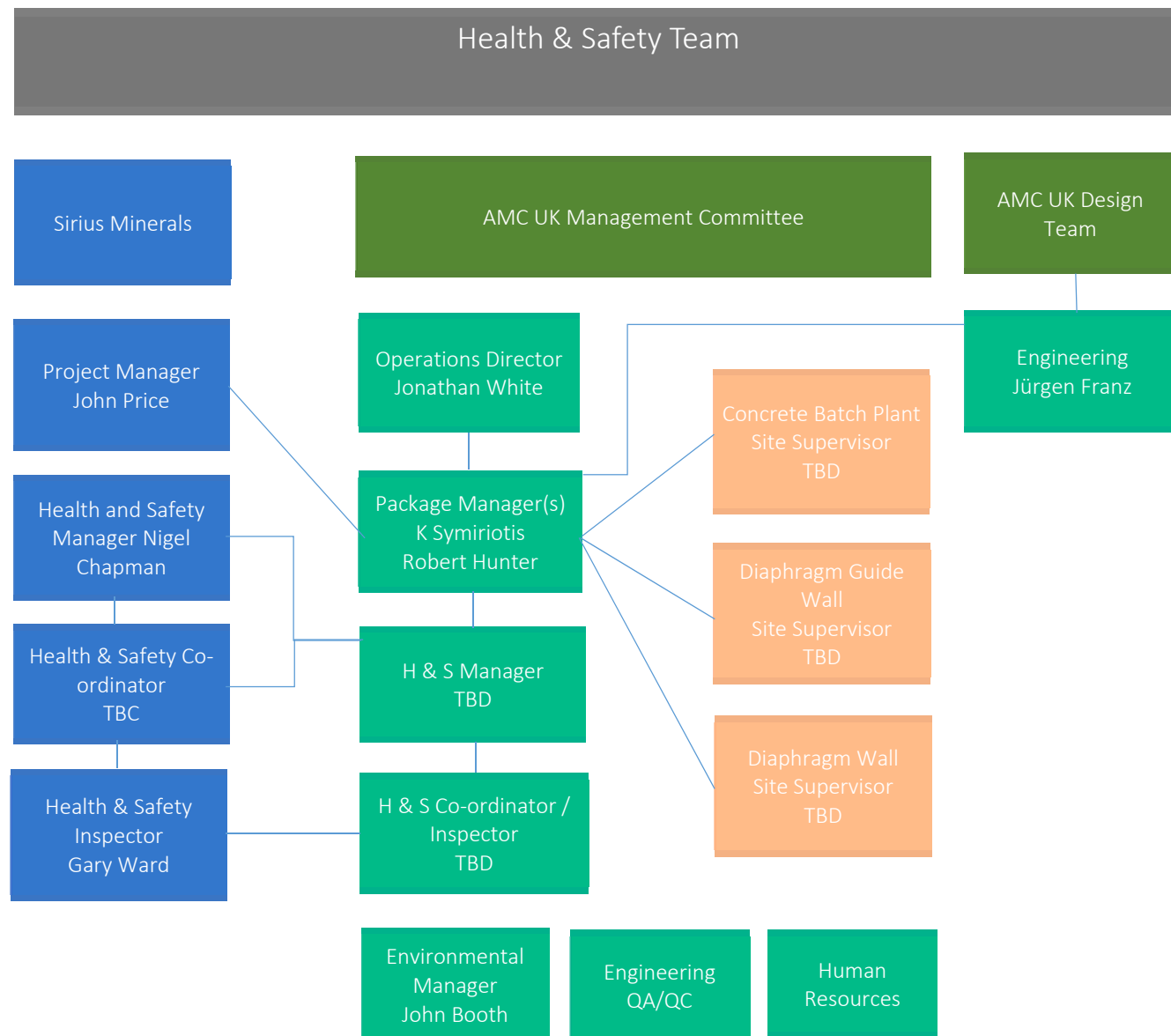

7.3.2. Health and Safety Responsibilities

The following outlines the responsibilities each person will hold with respect to health and safety performance across the contract.

7.3.2.1. Client

The Client (Sirius Minerals) is responsible for ensuring that the persons undertaking the works are suitably competent to safely deliver the works, ensuring a suitable CPHSP is in place before construction begins, allowing sufficient time and resources for all projects and legal and planning requirements of the overall project are fully complied with. The Client will receive monthly reports on health and safety matters as a part of established management processes.

7.3.2.2. Client's Project Manager

The Client's Project Manager is responsible for leading the construction phase of the project to a successful conclusion. The Client's Project Manager will be supported by the Client's Health and Safety Manager and Inspectors, as necessary.

Duties of the Client's Project Manager include:

- Implementing systems and processes which enable effective monitoring of health and safety compliance and quality of the project;
- Exercising controls and continuously monitoring the delivery of the project;
- Coordinating and directing the work of the Health and Safety Manager and Inspector(s);
- Reviewing the health and safety performance; and
- Advising the Client of any failure of the Contractor to meet its obligations under the Contract.

7.3.2.3. Designer(s)

A designer is an organisation or individual whose work involves preparing or modifying designs for construction projects, or arranging for, or instructing, others to do this. The role of designer includes the duty to eliminate, reduce or control foreseeable health and safety risks through the design process, such as those that may arise during construction work or in maintaining and using the building, facility or structure once it is built.

7.3.2.4. AMC UK Management

The AMC UK Management has overall responsibility for project support from its head office and is accountable to the Client. AMC UK Management is responsible for the following:

- Holding the project team accountable for Health and Safety performance through ongoing monitoring of project performance;
- Providing the physical and financial resources and management support necessary to carry out the works safely;
- Leading by positive example;
- Requiring the safe execution of contracted work and the implementation of the CPHSP;
- Emphasising to project team that Health and Safety issues must be given higher priority to cost, schedule, and quality;
- Facilitating and supporting the safe design and constructability process; and
- Building a 100% safe culture where incidents are an unacceptable consequence of performing work.

7.3.2.5. AMC UK Package Manager

The Package Manager has responsibility for planning, leading, organising, and controlling the various Phase 4 construction activities under their control. The Package Manager is responsible for the following:

- Taking ownership, support implementation, and actively participate in the Health and Safety program within their area of responsibility;
- Communicating Health and Safety objectives to employees and sub-contractors within their area of responsibility;
- Ensuring supervisors and employees know and understand their Health and Safety responsibilities and are held accountable for compliance;
- Emphasising to project team that Health and Safety issues must be given higher priority to cost, schedule, and quality;
- Ensuring that suitable risk assessments and method statements are prepared and reviewed prior to commencing works;
- Liaising with the Designer(s) for any design undertaken during the construction phase and provide the requested information for the health and safety file;
- Verifying area and field activity compliance to the CPHSP requirements;
- Implementing a system to ensure that identified corrective actions are followed-up to completion;
- Verifying sub-contractor compliance to the established Health and Safety requirements and take corrective action on noncompliance;
- Reviewing and taking action on safety issues; and
- Ensuring all safety personnel have the experience and support to fulfil their functions on the project and that these persons are approved by the Client.

7.3.2.6. AMC UK Health & Safety Manager

The AMC UK Health & Safety Manager has the overall responsibility for the CPHSP coordination and is accountable to the Project Manager. The Health & Safety Manager is responsible for the following:

- Coordinating project specific Health and Safety management systems;

- Helping develop and implement Health and Safety training, environmental, security, emergency response, and occupational health services plans;
- Communicating the Emergency Response Plan to all site project workers;
- Advising the Project Management team on Health and Safety issues;
- Preparing and issuing weekly and monthly Health and Safety performance reports;
- Monitoring compliance to project, client and regulatory requirements, and initiate corrective action through line supervision or senior management;
- Working with and be a resource to the Package Manager, senior management, line supervision, sub-contractors, and other project stakeholders on Health and Safety;
- Administering the project Health and Safety record keeping system.
- Participating in sub-contractor selection process, as required;
- Maintaining positive relationships with line supervision, customer, contractors, and regulatory enforcement representatives;
- Possessing sound knowledge of incident causation, incident investigation techniques, hazard identification and risk management processes;
- Establishing a system to ensure all actions identified during planned inspections, incident investigations, and Health and Safety communications are tracked to completion;
- Ensuring that incident investigators are trained and experienced in incident investigation and reporting technique;
- Conducting joint audits and workplace inspections;
- Assisting in developing procedures to implement site security policies;
- Identifying security loss exposures related to company personnel, operations, or assets; and
- Maintaining suitable First Aid cover for the site.

7.3.2.7. AMC UK and Sub-contractor Site Supervisors

Both AMC UK and sub-contractor Site Supervisors have the responsibility for planning, leading, organising, and controlling field activities within their area of responsibility. Supervisors are responsible for the following:

- Taking ownership, supporting implementation, and actively participating in the Health and Safety program within area of responsibility;
- Conducting pre-job hazard assessments and identifying mitigation methods;
- Ensuring tools and equipment required to execute the job safely are available;
- Enforcing compliance to site specific and regulatory Health and Safety requirements;
- Communicating Health and Safety performance expectations to crews;
- Investigating, or ensuring the investigation of, all incidents, regardless of severity; verify corrective action has been taken;
- Performing job observations and employ other such means to ensure compliance to established requirements;
- Knowing and understanding their role within an emergency response;
- Ensuring staff and employees possess the requisite training and demonstrated ability to do their work safely;
- Identifying and facilitating, in conjunction with Health and Safety Manager, training requirements and set up programs as required in order to safely complete upcoming work;
- Identifying and eliminating Health and Safety risks within area of responsibility;
- Conducting and documenting weekly inspections of work-site and initiate corrective action on observed substandard acts/conditions;
- Conducting and documenting daily pre shift briefings, toolbox and weekly safety meetings; and
- Possessing a valid first aid certificate, relevant plant and supervisor's certification.

7.4. Communication of Health and Safety Issues

Communication on Health and Safety is detailed in the Construction Phase Health and Safety Plan. This includes routine daily pre shift briefing meetings, planned Toolbox Talks and regular meetings and feedback.

7.5. Management of Health & Safety on Site

The framework for the management of health and safety during the Phase 4 Construction Works will involve a series of control documents/systems including:

- Company Policies;
- Safe Working Practices;
- Activity/Task specific Risk Assessments and Method Statements (RAMS);
- Permits to Work;

- Field Level Risk Assessments (FLRA);
- Workforce consultation via Daily pre shift briefing, Toolbox Talks and Regular Meetings.

The above outlines the formal framework for the management of health and safety. More important is a positive Health and Safety Culture and an engaged workforce. AMC UK will therefore from day one lead and foster good Health and Safety practices and behavioural safety on Site.

7.6. AMC UK Policies

As a minimum, AMC UK will ensure that work carried out is in accordance with relevant policies, legislation, Approved Codes of Practice (ACoPs) and guidance notes.

The AMC UK mission is to achieve zero harm culture through hazard recognition, education, skill training and clear accountability concerning safety and environmental performance. AMC UK is also committed to following project standards and guidelines for safety performance.

Reference should be made to the following AMC UK policy documents:

- Health and Safety Policy;
- Violence and Harassment Prevention Policy;
- Substance Abuse (Drugs and Alcohol) Policy;
- Environmental Policy; and
- Disciplinary Policy.

7.7. Safe Working Practices (SWPs)

The AMC UK Safe Working Practices (SWPs) provide guidance on the safest way to undertake general tasks or work activities and covers guidelines on how to perform the activities with minimum risk to people, equipment and the environment. For more technical work activities refer to the specific task or activity specific RAMS.

The following outlines the main SWPs:

1. SWP 001 Site Setup and Security
2. SWP 002 Fit for Duty
3. SWP 003 Field Level Risk Assessment
4. SWP 004 Manual Handling
5. SWP 005 Hand Tools
6. SWP 006 Work and Lifting Equipment
7. SWP 007 Heavy Machinery
8. SWP 008 Refuelling
9. SWP 009 Preventative Maintenance
10. SWP 010 Excavations
11. SWP 011 Work at Height
12. SWP 012 Rigging Guidance
13. SWP 013 Compressed Air
14. SWP 014 Hazardous Substances
15. SWP 015 Hot Work and Fire Watch
16. SWP 016 Flammable and Combustible Liquid Storage
17. SWP 017 Material Storage and Handling
18. SWP 018 Personal Protective Equipment
19. SWP 019 Job Observation Program

These SWPs shall be reviewed prior to the preparation of activity or task specific RAMS and prior to commencing any works for which this guidance is relevant.

7.8. Risk Assessments and Method Statements

7.8.1. Hazard Identification, Risk Assessment and Controls

Activity or Task Specific RAMS (Risk Assessment Method Statement) will be prepared for the effective management of all activities with foreseeable risks to Health & Safety and the environment. RAMS shall include details on the following:

- Location of activity and access arrangement.

- Work to be undertaken and methods of construction.
- Plant and materials to be used.
- Supervision requirements.
- Health and safety considerations - all issues identified in the health & safety risk assessment.
- Details of any permit or consent requirements.
- Identify significant environmental impacts that can be anticipated and how they are to be controlled.

All RAMS will be reviewed by the AMC UK Package Manager, Health and Safety Manager or nominated representative and agreed in advance of works commencing. AMC UK will keep a copy of all RAMS in the main Site office and will ensure that corrective actions identified in the documents (either during their preparation or use) are fully implemented. All RAMS will be kept under review and will be revised, updated, or re-written as a result of lessons learnt, changes in legislative requirements, incidents and/or as part of the continuous improvement of construction environmental management on Site.

7.8.2. Activity or Task Specific RAMS

It is anticipated that the following RAMS will be prepared:

Summary of Main Activity RAMS

	Main Works Activities	Organisation responsible for preparation of RAMS and delivery of works
1	Site set up and mobilisation of plant, machinery and workshop to site, including construction of cranes and plant.	Bauer
2	Set up, commissioning and operation of the bentonite batch plant.	Bauer
3	Installation of diaphragm wall guide walls.	Bauer
4	Construction of diaphragm walls at the Production, Service and Mineral Transport System (MTS) shafts.	Bauer
5	Operation of the concrete batching plant.	AMC UK

Other Task Specific RAMS for smaller works packages will be prepared as they are required.

7.8.3. Control of Substances Hazardous to Health

AMC UK will comply with the Control of Substances Hazardous to Health Regulations 2002 (COSHH) through employee training, maintaining documentation and performing workplace COSHH assessments.

Where possible the substances identified as hazardous to human health or the environment should be substituted for less harmful ones.

7.9. Permit System

A permit system will be adopted to ensure a safe and controlled system of work is employed for specific High Risk activities. Tasks requiring a permit must NOT be undertaken without a valid, signed permit and the permit signatory/holder being on site. All permits issued will be signed off upon completion of the work as stated below.

During the course of the Phase 4 Construction Works, it is anticipated that the following permit/combination of permits will be required:

Summary of Permits

PERMIT TYPE	REQUIRED	DURATION *	ACTIVITY/ LOCATION
Hot Work Permit	Yes	Duration of work	Welding and Cutting
Permit to Dig	Yes	Weekly	Ground excavation
Electrical Work Permit	Yes	Task	Isolation, connection and installation
Confined Space Permit	No	Daily	Entry
Lift Plan/Permit to Lift	Yes	Weekly	Mechanical lifting (mobilisation of plant, reinforcement cage installation etc.)

*Maximum of 1 week is allowed except for confined spaces which are daily, providing that the work is continuous and the details of the permit e.g. working party, conditions and method remain unchanged.

The permit system is outlined in the *AMC UK Permit to Work Woodsmith Mine* (Reference 40-AMC-WS-00-HS-FR-0019).

7.10. Field Level Risk Assessment

A Field Level Risk Assessment (FLRA) (or similar risk assessment approach such as a Point of Work Safety Assessment) will be used at the workplace before any activity commences in order to identify any changes in the working environment and/or to identify unforeseen hazards not identified in the Task or Activity RAMS. This activity will be led by the workforce supervisor and any potential changes to the RAMS or constraints on working communicated to the Health and Safety Advisor and Project Manager.

Further guidance on Field Level Risk Assessments is provided in SWP 003.

7.11. Job Observation Programme

AMC UK will demonstrate Felt Leadership via the completion of Job Observations, as defined in SWP 019.

7.12. Reporting/Investigation of Accidents, Incidents and Near Misses

All incidents resulting in injury to any employee, subcontractor or member of the public and any incidents regarded as dangerous occurrences must be reported in accordance with the Reporting of Injuries, Diseases and Dangerous Occurrences Regulations 2013 (RIDDOR). Site Management shall ensure that an Accident Book, GS0309, is available on site for recording any injury to anyone at the site.

All Incidents that require to be reported under the RIDDOR shall be reported by telephone to the Health and Safety Manager. All accidents reportable under the RIDDOR regulations shall be investigated and a report produced.

In the event of a Near Miss incident, it shall be reported to either the Health and Safety Manager or Environmental Manager by using an Incident Report Form. The Health and Safety Manager will respond to significant health and safety issues and the Environmental Manager will respond to any significant Environmental issues reported by the site.

All Sub-Contractors are obliged to pass information to AMC UK either verbally or in writing on accidents/incidents and near miss situations in accordance with the CPHSP and EMP.

7.13. Site Rules

The site rules will be communicated to and signed by any new employees. The Site Rules will be displayed in the Site Office and Canteen/Welfare buildings.

7.13.1. Drug and Alcohol Policy

The project will follow the AMC UK Substance Abuse Policy and procedures. Both employees and sub-contractors (including supervisory and management staff) are subject to the policy. Employees and sub-contractors involved in an accident/incident may be tested for drugs and alcohol.

7.14. Emergency Procedures

All Emergency Procedures and Incident Reporting are covered by the Emergency Response Plan (ERP) appended to the CPHSP. This ERP will be displayed on site and regular practices of the emergency procedures undertaken.

7.14.1. First Aid

The provision of First Aid facilities will include First Aid kits at the Site Offices, concrete batch plant, bentonite batch plant and within all AMC UK vehicles.

Sirius Minerals will provide site wide trained First Aid/medical staff. In addition key AMC UK and sub-contractor personnel will be first aid trained.

7.14.2. Fire

Fire management is outlined in the Site *Fire Management Plan* and the *Emergency Response Plan*. In summary, personnel will attempt to fight small fires (if competent to do so) while not exposing them to undue risk. A check of personnel using the sign in register is to be conducted at the muster points and the emergency services called, if required.

7.14.3. Damage of Underground Services

Where damage is caused to underground services the AMC UK Emergency Response Plan will be followed. This follows guidelines documented in publication HSG 47 Avoiding Danger From Underground Services (Third Edition) (HSE 2014).

7.14.4. Liquid/Chemical Spills

Spill kits will be placed at strategic locations around the site at key storage areas and fuel handling locations. These spill kits are to be used to contain small spills and have absorbents to soak up liquids. Care should be taken if the spill involves hazardous chemicals and spill kits should not be used if there is any risk to the person(s) attempting a clean-up.

Large spills should be contained by barriers and cut off ditches where possible. Where a serious incident has occurred which is likely to cause serious pollution or flooding then the Environment Agency will be contacted (Tel: 0800 807060).

7.15. Auditing and Reporting Performance

Monitoring, auditing and reporting of health and safety performance will be completed by the Health and Safety Manager with the support of the Site Health and Safety team to ensure that the requirements of the Construction Phase Health and Safety Plan and this PMP are fully implemented on site.

The process of auditing, monitoring and reporting the performance of health and safety is outlined in the Construction Phase Health and Safety Plan. This will include daily *Informal Inspections* completed by the Site Supervisor, weekly *Formal Inspections* by the Health and Safety Manager and *Leadership / Management Audits* which are formal audits completed by AMC UK Senior Management.

The inspections and audits will determine if the works are compliant with the defined procedures and will provide feedback (positive or negative) to the relevant workers. Where the activity is not compliant, then a Corrective Action Report will be generated in line with the Non-Compliance Procedure. If a significant hazard is identified then works will be immediately stopped and appropriate actions undertaken to rectify the situation.

In addition to the above, routine inspections will also be undertaken on all equipment and machinery, tools, rigging and cables. These items include, but are not limited to:

- Ladders and scaffolding;
- Electrical equipment, such as cords, electrical tools and generators;
- Rigging equipment, such as shackles, slings, hooks, come-along and chain falls;
- Fall arrest equipment such as harnesses, lanyards, lifelines, horizontal cable lines, and rope grabs.
- Vehicles;
- Mobile Equipment, including excavators, MEWPs;
- Crawler Cranes and Diaphragm Wall cutters; and
- Temporary Facilities.

AMC UK and nominated sub-contractors (based on operational responsibilities) will record all such inspections on the AMC UK forms or registers.

SECTION 8 - ENVIRONMENTAL MANAGEMENT

8.1. Environmental Management Documentation

Environmental management within the project will be completed in accordance with:

- Environmental Management Plan (EMP) – *AMC UK Environmental Management Plan (EMP) Woodsmith Mine Phase 4 – Diaphragm Wall Construction* (Reference 40-AMC-WS-71-EN-PL-0004).
- Site Waste Management Plan – *AMC UK Site Waste Management Plan (SWMP) Woodsmith Mine Site - Phase 4 – Diaphragm Wall Construction* (Reference 40-AMC-WS-71-EN-PL-0006, appended to the EMP).

For emergency situations, guidance is provided in:

- Environmental Emergency Preparedness Plan – *AMC UK Environmental Emergency Preparedness Plan Woodsmith Mine Site - Phase 4 – Diaphragm Wall Construction* (Reference 40-AMC-WS-71-EN-PL-0005, appended to the EMP).

8.2. Environmental Permits/Consents and Constraints

Any environmental permit or consent applied for/issued to AMC UK as part of this works, or site constraints, must be logged and notified to the Client. This is to allow proactive monitoring of all consents and associated duties held by AMC UK. The Environmental consents and permissions which are applicable on the project include:

Type of Consent	Regulator	Required	Activity or Location	Start Date
Environmental Permit for Flood Risk Activity (works in/near watercourses)	Environment Agency	No		
Ordinary Watercourse Consent (works in/near Ordinary watercourses)	Local Authority / Internal Drainage Board	No		
Environmental Permits: - Water Discharge Consent - Abstraction	Environment Agency	No		
Groundwater Permits		No		
Environmental Permit (Waste)		No		
Waste Exemptions	Environment Agency / Local Authority	No		
Registered Waste Carrier	Environment Agency	No		
Planning Permission	Local Planning Authority	Yes	Phase 4	July 2017
Hedgerow Removal	Local Authority	No		
Footpath Diversions (temporary/permanent)	Local Authority	No		
Protected Species Licenses e.g. Bats / Badgers / Great Crested Newts	DEFRA	No		
Scheduled Ancient Monuments	Ministry for Culture, Media and Sport	No		
Consent to work in SSSIs	Natural England	No		
Tree Preservation Orders	Local Authority	No		
Listed Building Consent	Local Authority	No		
Conservation Area Consent	Local Authority	No		
Construction (noise) Consent	Local Authority	No		

8.3. Environmental – Golden Rules

WASTE:

- Kept safe or secure in suitable containers to prevent pollution or harm.
- Re-use and recycle waste where possible – always dispose of in the correct skip.
- Hazardous wastes must not be mixed together or with general waste.
- Waste disposals must be fully documented.

WATER

- Ensure all consents/permits are in place.
- Must not contaminate water for example by disposal of a substance causing pollution.

CONSERVATION

- Ensure all permissions are in place – stop work if you find a protected plant or animal.

NOISE AND VIBRATION

- Switch off equipment when not in use – notify and inform co-workers.
- Operate and maintain plant and machinery preventing/minimizing noise/vibration.

AIR POLLUTION

- Reduce emissions – keep to site speed limits – use extraction equipment or practical means to prevent windblown dust.

- Plant and machinery maintained – preventing and minimizing emissions/dust.
- RESOURCES**
- Switch off equipment – report water leaks – only order what you need.
 - Use energy efficiently – avoid waste.
- INCIDENTS**
- Always report Environmental Incidents / Near Misses / Positive Interventions however small.
- ASPECTS AND IMPACTS**
- Complete/Review/Update the Aspects and Impacts Register for the site.
- DRIP TRAYS**
- Use drip trays – maintain and lock fuel bowsers.
- FUELS, LUBRICANTS AND CHEMICALS**
- Adhere to procedures for storage, handling and dealing with spillages of these substances. Be familiar with the Environmental Emergency Preparedness Plan.
- TRANSPORT**
- Vehicles leaving site must use the wheel/vehicle cleaning facilities provided by Sirius Minerals.
- SITE CLEANLINESS/HOUSEKEEPING**
- Keep site tidy at all times and ensure it is left in a clean and tidy condition when leaving site.
- HOURS OF WORK**
- Be familiar with and comply with restrictions on working hours.

8.4. Implementation of the Environmental Management Plan

8.4.1. Organizational Chart

The following organizational chart shows the key personnel responsible for implementing this Environmental Management Plan:

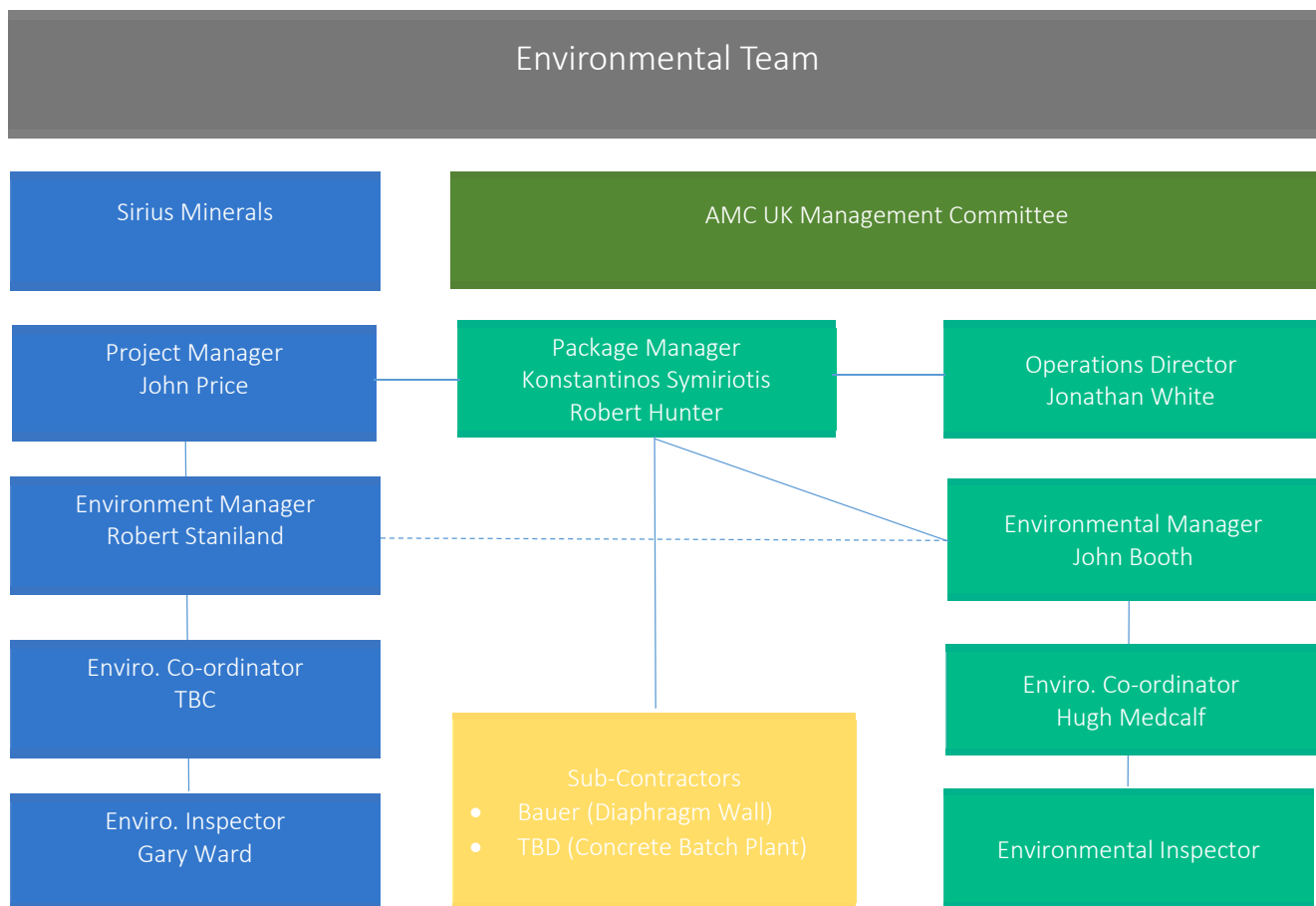

8.4.2. Responsibilities

The following outlines the responsibilities of each person will hold with respect to environmental performance across the contract.

8.4.2.1. Client

The Client (Sirius Minerals) is responsible for ensuring that the legal and planning requirements of the overall project are fully complied with. The Client will receive monthly reports on environmental matters as a part of established management processes.

8.4.2.2. Client's Project Manager

The Client's Project Manager is responsible for leading the construction phase of the project to a successful conclusion. The Client's Project Manager will be supported by the Client's Environment Manager and Inspectors, as necessary.

Duties of the Client's Project Manager include:

- Implementing systems and processes which enable effective monitoring of environmental compliance and quality of the project;
- Exercising controls and continuously monitoring the delivery of the project;
- Coordinating and leading the work of the Client's Environment Manager and Inspector(s);
- Reviewing the status of environmental performance and reporting to the Client; and
- Advising the Client of any failure of the Contractor to meet its obligations under the Contract.

8.4.2.3. AMC UK Package Manager(s)

The AMC UK Package Manager is responsible for ensuring the effective management of all construction issues, including the environmental requirements outlined in this PMP, the client Construction Environmental Management Plan, the AMC UK EMP, other relevant planning documentation and the Client's contract documents. The AMC UK Package Manager will be responsible for regular review of this PMP and will receive and generate monthly reports on environmental matters associated with it.

The AMC UK Package Manager has responsibility for the delivery of environmental objectives throughout construction. This includes ensuring the dissemination of environmental information, including waste reduction and waste management procedures, and water sustainability matters to all relevant personnel on site and the application of environmental requirements during the construction process.

The AMC UK Package Manager will ensure that appropriate resources are available and any necessary environmental controls or mitigation measures are implemented. This includes those identified through environmental audits of the site works.

Duties of the AMC UK Package Manager include:

- Planning and ensuring that all environmental inductions are undertaken.
- Planning and ensuring that weekly environmental inspections of the site are undertaken.
- Ensuring the environmental competence of all personnel working on the project.
- Managing and supporting of all other environmental staff on site.
- Acting as the main point of contact with other (internal and external) parties for environmental matters, including complaints, concerns and general enquires.
- Monitoring construction activities to ensure that identified control measures are effective and in compliance with this PMP and the AMC UK EMP.
- Reviewing the environmental inspection reports and ensuring that any issues are resolved.
- Reviewing and updating this PMP, as required.
- Reviewing and revising construction method statements for environmental aspects of the work.
- Providing information to the Client's Environment Manager for inclusion in progress meetings, on a monthly basis.
- Ensure the Client's Environment Manager is fully informed on all environmental matters as construction works proceed.
- Being available for construction site audits with the Client's Project or Environment Manager(s) as required.

8.4.2.4. AMC UK Environmental Manager

The AMC UK Environmental Manager will have responsibility for the environmental aspects of the work and the provisions outlined in the AMC UK EMP and this PMP. The AMC UK Environmental Manager will ensure compliance with environmental aspects of the construction works through the Environmental co-ordinators, together with any necessary monitoring, and will report directly to the AMC UK Package Manager.

Duties of the AMC UK Environmental Manager include:

- Identifying and monitoring trends and identifying areas for environmental improvement.
- Advising when control measures are not effective and/or not being fully implemented and suggesting alternative mitigation as required.
- Reviewing and updating Environmental Procedures, as required.
- Providing feedback to the Contractor and their personnel on environmental impacts and risks prior to the commencement of any part of the works.
- Planning and undertaking quarterly environmental audits of the work and reporting to the Client's Project Manager.
- Being available for construction site audits with the Client's Project or Environment Manager(s) as required.

8.4.2.5. AMC UK Site Environmental Co-ordinator

Site Environmental Co-ordinators will be identified by the AMC UK Environmental Manager for overseeing specific construction activities on site.

Together with the AMC UK Environmental Manager, the AMC UK Site Environmental Co-ordinator(s) will form the core of the site Environmental Team (*role may be undertaken by AMC UK Site Supervisors*). The AMC UK Environmental Manager will provide the Site Environmental Co-ordinator(s) and any subsequent team members with a specific induction for the role prior to commencement of work and will be available for advice and guidance to them on an on-going basis.

Duties of the AMC UK Site Environmental Co-ordinator(s) include:

- Consider how approaches for different aspects of the works can contribute to environmental improvement in performance and present these to the AMC UK Package Manager for consideration.
- Act as a conduit for dissemination of issues and lessons learnt across the site (through provision of toolbox talks).
- Ensuring implementation and monitoring of (the control of) nuisance matters such as noise, dust, light, slurry loss to permeable geology, silt management, surface water management and conduct on site that may have environmental implications.
- Plan work to ensure that all inspections, reviews of documentation and other activities are undertaken in a timely manner and that all issues are reported and acted on.
- Attend site environmental audits with the AMC UK Environmental Manager and Package Manager or their advisors within the area they have responsibility for, as required.
- Ensure the AMC UK Environmental Manager and Package Manager are fully informed on all environmental matters as construction works proceed.
- Contribute to regular updates of the EMP and this PMP, as well as the preparation of method statements, task briefing sheets and risk assessments.

8.4.2.6. AMC UK Environmental Inspector

The AMC UK Environmental Inspector (*role may be undertaken by AMC UK Environmental Co-ordinator or Environmental Manager*) has responsibility for monitoring and auditing the compliance with environmental legislation, and conformance with the environmental procedures outlined in the EMP and this PMP.

Duties of the Contractor's Environmental Inspector include:

- Monitoring, auditing and reporting on the Contractor's compliance with environmental legislation, planning requirements, permits, licences and any other requirements.
- Monitoring, auditing and reporting on the Contractor's conformance with its environmental management procedures.

- Monitoring and reporting on the implementation and effectiveness of preventative and corrective actions.

Based on the size of the work, this role may be incorporated with the Site Environmental Co-ordinator role.

8.4.3. Communication of Environmental Issues

8.4.3.1. Site Inductions and Toolbox Talks

Refer to Section 6 of the Environmental Management Plan (refer to Appendix B of this document).

8.4.3.2. Communication with Site Staff

Refer to Section 5.1 of the Environmental Management Plan (refer to Appendix B of this document).

8.4.3.3. Communication within the Contractor's Environmental Team

Refer to Section 5.2 of the Environmental Management Plan (refer to Appendix B of this document).

8.5. Management of Environmental Issues on Site

8.5.1. Supervision of Construction Activities

All construction and installation activities, including those carried out by sub-contractors, will be supervised by the AMC UK Package Manager with the support of members of their team on a daily basis. The Sub-Contractor's Project Manager and team will receive briefing from the AMC UK Environmental Manager to ensure that they are aware of the environmental requirements identified in risk assessments and method statements. The briefing will also ensure that they are able to assess whether the environmental requirements are being implemented properly.

8.5.2. Monitoring Environmental Impacts during Construction

Environmental management identified within the Environmental Management Plan, this PMP and other related documents, will be subject to inspections by the AMC UK Site Environmental Co-ordinator at least once a week. These inspections will seek to confirm that:

- Construction works are progressing in accordance with the agreed RAMS and Daily pre shift briefings.
- Agreed controls, protection and mitigation measures (including those detailed within the EMP) are in place prior to or during the implementation of construction activities.
- Construction works have been completed in accordance with commitments made during the statutory process as set out within permits, licences and consents.

Inspections will be recorded on inspections forms which will be adapted to suit a specific site (such as waste management, silt and water management, pollution prevention and controls, noise and air pollution, storage of hazardous materials and energy, fuel and water consumption). The forms will outline the work being undertaken on site at the time of the inspection, any good practice identified and/or any improvements made, and will also contain a section for the Contractor to record any improvements made as a result of the inspection. This will ensure that records of issues identified and remedial works undertaken are recorded in the same place and that any outstanding issues can be closed off. Photographs and other records can also be added to this form.

The AMC UK Environmental Manager will carry out an inspection of the construction areas, prior to the monthly meetings, to verify that the required methods and mitigation measures are being implemented effectively and will draw on information from the weekly inspection reports produced by the AMC UK Site Environmental Co-ordinator.

Records of water, fuel and power consumption will be maintained by the AMC UK Package Manager and will include metrics to measure aspects of performance, such as waste minimisation, recycling and reuse of materials. The metrics will include the volumes of different waste streams produced, the volumes of waste recycled and volumes of waste disposed of off-site.

8.5.3. Environmental Studies and Surveys

Copies of completed environmental studies or surveys will be kept on site for reference purposes. Mitigation measures identified in the surveys are to be incorporated into the site specific aspects and impacts assessment.

8.5.4. Protected Species and Precautionary Method of Working

The Construction Environmental Management Plan (CEMP) outlines precautionary methods of working which will be adopted to protect reptiles, birds, and other protected species which may be found on site.

8.5.5. Environmental Monitoring and Measurement

Mitigation measures identified during surveys or outlined in licences and permissions (such as noise monitoring, water sampling to monitor water discharges etc.) will be incorporated into the site specific Environmental Aspects and Impacts Assessment (EAIA), refer to Section 8.5.17.

8.5.6. Environmentally Significant Changes

Any potential changes in the proposed work processes or implementation must be communicated by the AMC UK Package Manager to the Client's Environment Manager immediately who will advise the Client's Project Manager. The Client's Environment and Project Managers will assess the significance of any changes and decide whether specific consultation or revision to this PMP and supporting documents is required.

8.5.7. Environment and Sustainability

This project will be managed in a sustainable manner, using resources efficiently, protecting and enhancing the environment in which we work and reducing our impacts.

In order to undertake this project in a sustainable manner, during the planning and implementation phase of a project, a number of key areas will be considered:

- Aim to reduce carbon emissions;
- Aim to reduce water consumption;
- Reduce, reuse and recycle waste in preference to disposal;
- Use sustainable practices and materials;
- Conserve and enhance the areas in which we work; and
- Use local resources wherever possible.

8.5.8. Site Waste Management Plan (SWMP)

The Site Waste Management Plan (SWMP) is appended to the Environmental Management Plan (refer to Appendix B in this document).

8.5.9. Considerations With Respect to Air

Considerations regarding environmental air quality to meet legislation such as the Clean Air Act etc. will be made in conjunction with health and safety considerations under the Control of Substances Hazardous to Health Regulations 2002.

No fires are permitted on site for the burning of waste or any other use.

Dust Management is outlined in the Construction Environmental Management Plan.

8.5.10. Considerations With Respect to Land and Water

8.5.10.1. Silt and Surface Water Management

The surface water drainage design will be implemented ahead of AMC UK works. These works comprise:

- A silt removal facility;
- An attenuation pond;
- Swales and ditches with check dams;
- Silt fencing; and
- Oil separator tanks.

Monitoring of the effectiveness of the above measures will be recorded on daily inspection sheets by AMC UK and on-site inspection reports by the Environmental Co-coordinators and/or Environmental Manager during their inspections. These will be stored along with a record of the actions that were taken in the event of issues arising and their effectiveness.

8.5.11. Considerations with Respect to Noise and Vibration

AMC UK will employ "best practical means" to minimise noise and vibration resulting from its operations and shall comply with the recommendations detailed in the Code of Practice for noise and vibration control on construction and open sites (BS 5228-1: 2009 & BS 5228-2:2009) and the noise limits identified in the planning permission.

The Noise and Vibration Management Plan details the noise restrictions, and residential receptor and boundary noise monitoring locations.

8.5.12. Archaeology and the Built Heritage

AMC UK's work areas will already be prepared for construction purposes. Therefore it is unlikely that archaeological or historical features will be found during construction works.

If any unexpected finds are encountered works will immediately be stopped, the area will be blocked off and the advice of a qualified archaeologist sought.

8.5.13. Plant and Wheel Wash Arrangements

Site wide wheel-wash facilities will be installed and operated on the access road to the site (by Sirius Minerals). These facilities will be used by all vehicles accessing and leaving the site.

All wheel washes will be self-contained, with waste water re-used and removed off site as appropriate.

8.5.14. Slurry Loss to Permeable Geological Units

During the excavation and construction of the diaphragm wall, there is a potential for bentonite slurry loss to occur into formations of more permeable geological units. The management of slurry to address this issue is outlined in the Bauer *Slurry Management Plan* and the AMC UK *Environmental Emergency Preparedness Plan*. The plans address actions to be taken in the event of a slurry loss (assessed either via real time monitoring of adjacent monitoring wells or via an observed drop in slurry levels in the diaphragm wall panels being cut).

8.5.15. Light Pollution

Works will be undertaken during day time and night time. When illumination is required, the following will apply:

- Directional tower lighting with directional lanterns will be used, with lights directed down towards the area required to be lit and away from any area of concern (e.g. roads).
- Lights will be switched off when not in use.
- Task lighting will be used where appropriate to light up local areas of small works instead of mast illumination affecting a large radius.
- The lighting will comply with the lowest recommended criteria within the relevant British Standards and relevant Chartered Institution of Building Services Engineers Lighting Guides¹.
- Lighting will comply with the Interim Guidance: Artificial lighting and wildlife: Recommendations to help minimise the impact artificial lighting².

¹ BS EN 12464-2 *Lighting of work places – Outdoor work place.*
CIBSE *Lighting Guide 1 – Lighting of the industrial environment.*
CIBSE *Lighting Guide 6 – Lighting of the outdoor environment*

² Bat Conservation Trust *Interim Guidance Lighting*, June 2015 http://www.bats.org.uk/pages/bats_and_lighting.html

8.5.16. Carbon Reduction and Energy Management

AMC UK will take all reasonable measures to reduce energy and fuel consumption and minimise carbon emissions from activities relating to the construction project.

Vehicles and items of plant should be switched off when not in use.

Office accommodation on construction projects or at depots will be well insulated to prevent excess heat loss and energy efficiency measures used where possible, for example timer controlled heating and movement activated lighting. Electrical equipment should be energy efficient and switched off when not in use.

Travel to and from sites should be minimised and the utilisation of video and telephone conferencing encouraged. Journeys will be planned to minimise fuel use, and alternative methods of travel will be encouraged such as car sharing, bus, train travel.

Local suppliers of materials will be used and deliveries planned to minimise unnecessary journeys.

8.5.17. Environmental Aspects and Impacts Assessment

The environmental objective of AMC UK is to continually improve our environmental performance to prevent or minimise pollution, minimise waste and to conform to Environmental Legislation, Regulations and Company Policies and Procedures.

AMC UK will ensure all activities undertaken on site will be subject to an Environmental Aspects and Impacts Assessment (EAIA). The EAIA will be prepared with regard to the information in the CEMP, this PMP and all other relevant documents. These will:

- Identify any significant environmental impacts that can be anticipated.
- Assess the risks from these impacts.
- Identify control measures to mitigate the risk.
- Report any unacceptable residual risk such that changes can be implemented to reduce the risk to an acceptable level.

The findings of each EAIA and, in particular, the necessary controls to reduce risk, will be incorporated into the Task/Activity RAMS, as required. These documents shall be briefed to all site operatives involved in the works prior to the commencement of activities on site. Daily pre shift brief shall be used to target environmental issues of particular significance at relevant times throughout the works.

Should any aspect of the scheme change, the EAIA will be updated accordingly.

The Contractor will keep a copy of all EIAs in the main site office and will ensure that all control measures identified to control risk are fully implemented.

8.5.18. Control of Substances Hazardous to the Environment

AMC UK will comply with the Control of Substances Hazardous to Health Regulations 2002 (COSHH) through employee training, maintaining documentation and performing work assessments.

Where possible the substances identified as hazardous to the Environment should be substituted for less harmful ones.

8.5.18.1. Fuel

Guidance on fuel storage and handling is provided in the AMC UK *Pollution Prevention Guidance PPG001 (Fuel Storage and Handling)* appended to the EMP.

Fuel will be delivered to the Woodsmith Mine by fuel tankers to either static fuel tanks (for generators) or mobile fuel bowsers. The static fuel tanks and towable bowsers will be bunded and have at least 110% of the storage capacity. The tanks and bowsers themselves will be stored on an impervious hardstanding away from surface watercourses and drainage.

Refuelling on site will be undertaken in accordance with the Safe Works Practices SWP008 (appended to the CPHSP), using drip trays and plant nappies to ensure that any spillages are contained. There will be no refuelling in or near excavations. In the event of a fuel spillage, this will be cleared up using an oil spill kit stored adjacent to the storage areas as well as at other key locations around the site.

8.5.18.2. Chemicals

All chemicals will be stored in sealed containers on a suitably bunded, impervious hardstanding or in suitable storage cabinets (refer to AMC UK *Pollution Prevention Guidance PPG004 (Housekeeping)* appended to the EMP). The chemical storage area will be located away from drains and watercourses. In the event of a spillage, this will be cleared up using spill kits stored adjacent to the storage areas.

8.5.18.3. Bentonite Slurry

Bentonite slurry is predominantly water and bentonite. Bentonite is a natural absorbent aluminium phyllosilicate clay and has no significant environmental impacts. The Bauer *Slurry Management Plan (Bentonite)* outlines the potential additives which could be used to adjust pH, viscosity levels and physical properties of the slurry. The slurry management plan provides information on the minimal volumes of additives required to maintain or increase the working lifespan of the slurry and presents the Material Safety Data Sheets (MSDS) for each of these additives, which indicate no significant environmental implications for their use.

8.5.19. Environmental Incidents and Near Misses

The Environmental Emergency Response Plan (EERP) is appended in the Environmental Management Plan (refer to Appendix B of this document). The EERP will be communicated to all staff and displayed on site notice boards.

All incidents resulting in pollution or a Near Miss incident must be recorded on an Incident Reporting Form.

The AMC UK Environmental Manager or designate will respond to any significant Environmental issues reported by the site. In the event of a pollution incident the Environmental Emergency Preparedness Plan must be followed. The Package Manager / Environmental Manager will be informed immediately and immediate steps taken to minimise the impact of the incident. Spill kits will be available on site for use in the event of a spillage.

8.6. Auditing and Controlling Environmental Performance

Monitoring environmental performance on site by the AMC UK Environmental Manager and inspections by the AMC UK Site Environmental Team are key to ensure that the requirements of the Environmental Management Plan and this PMP are fully implemented on site. It is important that the results of the monitoring are audited on a regular basis to ensure that any issues are identified and that changes to the operations on site can be made if required.

The site inspection reports will be audited by the AMC UK Package Manager on a regular basis and reported at the monthly progress meetings, with recommendations for improvements made where necessary. AMC UK shall undertake formal monthly site inspections and quarterly audits to ensure that the environmental controls detailed within this PMP, and other relevant environmental documents, are being implemented.

Reports of environmental inspections undertaken on site will be reviewed by the AMC UK Environmental Manager to enable re-occurring issues to be identified at an early stage. The AMC UK Environmental Manager must identify the cause of any re-occurring issues and work with the Package Manager and the Client's representatives to identify actions to be taken to rectify to solution.

The AMC UK Environmental Manager will carry out an audit of environmental performance on site, based upon reports from the Contractor's Environmental Team and responses from the Contractor where required. This will be carried out on a monthly basis and will be reported at the monthly progress meetings.

The AMC UK Environmental Team will meet on a monthly basis to discuss the works being undertaken on site and any environmental issues identified. Minutes of these meetings will be forwarded to the AMC UK Package Manager, the Client's Project Manager and the Client's Environment Manager.

An assessment of the performance over the month, including information about water, fuel and power usage will be made and quantified, where possible and also reported at the monthly progress meetings.

The Construction Traffic Management Plan sets out how off site vehicle movements will be monitored. Monitoring, will include; numbers of employees vehicles, HGVs, parking demand, road accidents and near misses etc. Further detail is provided within the Construction Traffic Management Plan.

8.6.1. Reporting Environmental Performance

Reports of all environmental audits, as well as monthly progress reports on inspections undertaken, construction activities, environmental performance and minutes from the monthly Contractor's Environmental Team meetings will be forwarded by the AMC UK Package Manager to the Client's Project Manager and the Client's Environment Manager. Copies of these documents, as well as an updated a register of incidents and actions taken, will be held on site and will be available for inspection by the statutory bodies, as required.

Monthly Progress Meetings will be used to disseminate the results of monitoring and audit reports. At these meetings, a review of the environmental performance on site to date will be undertaken and any improvements required during the construction phase will be identified. Details of where sustainable construction has been implemented or developed as the work proceeds will also be discussed and recorded and its suitability for implementation at other areas of the site will be considered and applied where appropriated. Decisions about amendments required to the processes and procedures will also be agreed at this time.

On completion of the Phase 4 works, a report detailing how AMC UK has complied with all elements of the Construction Environmental Management Plan, this PMP and supporting documentation relating to other environmental, planning and approvals requirements will be provided and will be issued to Sirius Minerals.

SECTION 9 - PROJECT COMMUNICATIONS

9.1. Project Communications

9.1.1. Regular Liaison between Parties

AMC UK will maintain regular project meetings with Sirius Minerals, the project team and the workforce.

Regular liaison meetings will be held by Sirius Minerals with external stakeholders, such as the Local Authorities, Health and Safety Executive, the Environment Agency, and other government bodies such as DEFRA (Department for Environment, Food and Rural Affairs) throughout the duration of the project (as required). In addition, the involvement of the local community and local residents/stakeholders will be encouraged. AMC UK will attend meetings with relevant stakeholders as required.

9.1.2. Complaints Procedure

The client has developed the following Complaints Procedure, which will be implemented during the works.

All complaints or recommendations received from members of the public shall be reported to the Package Manager via the Sirius Minerals Complaints Procedure and shall arrange suitable action or corrective action to be implemented.

Further to the above procedures, the following Sirius Minerals' documents shall be adhered to, which shall be maintained in the Site Office at all times throughout construction.

- Community and Stakeholder Engagement Plan.
- Complaints Procedure.

The procedure below outlines the process of managing complaints from receipt through to resolution. All complaints, regardless of the source, will be managed by the Sirius Minerals External Affairs team and will involve the Company's Project team, contractors and other parties as appropriate.

Procedure for managing complaints from receipt through to resolution

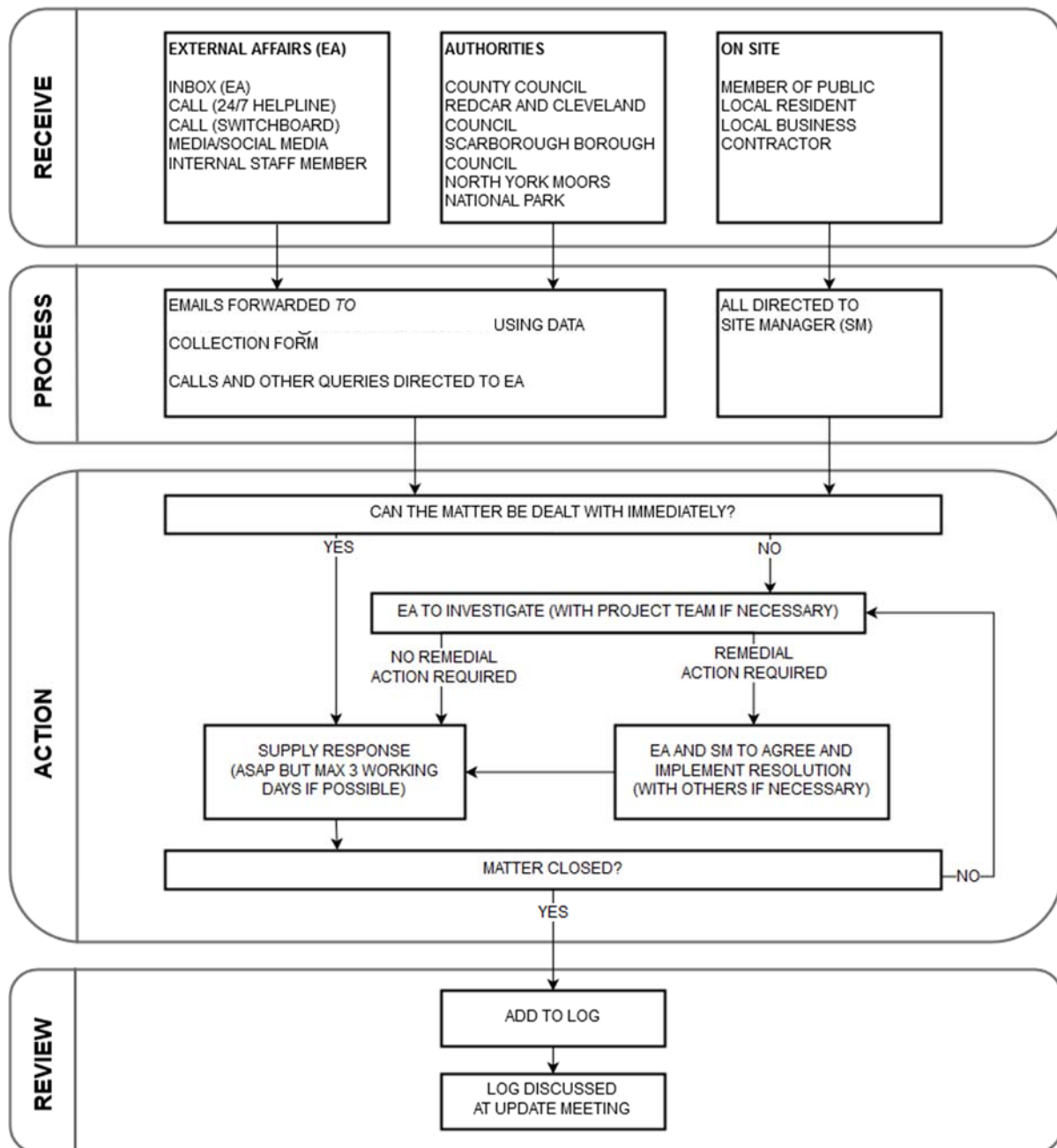

9.2. Internal Consultation Process

Meetings will be held as detailed below to secure co-operation between the Client, Designer, Contractor, other Contractors and Designers to ensure that Health and Safety objectives are being adequately addressed and achieved.

Meeting/Report Type	Client Requirement	AMC UK Requirement	Sub Contractors	Frequency					
				As Required	Daily	Weekly	Monthly	Quarterly	Once
Sirius Minerals Site Induction to Woodsmith Mine Site	x	x	x						x
AMC UK Induction		x	x	x					
Subcontractors pre-commencement meetings	x	x	x						x
Activity briefings		x	x		x				
Informal daily monitoring of construction works (environmental and health & safety)		x	x		x				
Progress photographs	x	x		x					
Environmental Alerts		x	x				x		
Safety Alerts		x	x				x		
Sirius Minerals weekly inspections by the Environment Team	x					x			
Woodsmith Mine site contractors coordination meetings	x	x	x			x			
AMC UK routine inspections (environmental and health & safety)		x	x		x				
AMC UK formal inspections/audit (environmental and health & safety)		x				x			
Health, Safety and Environmental Inspection Report	x	x				x			
AMC UK contractors progress meetings (including QESH review)		x	x			x			
Progress reports (environmental and health & safety)		x					x		
Monthly Joint Site Safety and Environmental Site Meeting	x	x					x		
Project progress meetings	x	x					x		
AMC UK Management EMP Performance Audit		x	x					x	
AMC UK Management H&S Performance Audit		x	x					x	
Health & Safety Representatives Meeting (safety committee)	x	x	x				x		

9.2.1. Consultation with the Workforce

Managers/Supervisors will communicate daily to the operatives they are responsible for via a Daily pre shift briefing, which is a daily brief of site activities to be undertaken that day and highlighting any health and safety or environmental controls that may require special attention.

As part of the communication and the documented monitoring process, all operatives will be asked to communicate any health, safety or environment issues they may have. Brother's Keeper cards will also be provided in the Site Office and Welfare facilities to encourage open communications on all matters. Issues raised will be logged on the tracking spreadsheet, raising a "pending action", until satisfactorily closed-out.

On a monthly basis there will be Representatives of Health and Safety (RoHS) meetings between management and employee representatives. The meeting dates and minutes are issued by the Health and Safety Manager.

Should there be non-English speaking operatives on site these will be managed through the use of an interpreter to be supplied by the contractor or subcontractor. This can either be in the form of a professional translator – or a

bilingual member of the team. This translator will be used to ensure that all members of the team understand the site induction and the method statement briefing.

More information on consultation with the workforce on environmental and health and safety matters is contained within the EMP and CPHSP management plans.

9.2.2. Communication with Sub-Contractors

AMC UK will carry out regular meetings with its sub-contractors and supply chain to ensure the co-ordination of works and Health and Safety and Environmental issues (refer to Section 9.2 for meeting details).

9.2.3. The Exchange of Design Information

Regular meetings, for the purpose of exchange of design information, will be set up in agreement with the Package Manager. These will include, where appropriate, the client, client's representatives, designers, contractors and other interested parties.

9.2.4. Managing Design Changes

Design changes will be managed in accordance with the relevant procedures. Where the Package Manager identifies that the construction or installation activity cannot proceed or continue as planned he will inform the client. A visit to the site may be arranged to discuss and instruct any minor changes, these will be confirmed in writing to the designer and the client.

Where major changes are required, the Package Manager may close down the site and contact the designer and seek a re-design. Upon receiving a revised design this shall be communicated to the team undertaking the activity and the works will recommence. Changes to existing consents, or additional consents, will be obtained, as required by the change.

Designers are required, as far as reasonably practicable, to identify foreseeable risks to health and safety associated with the design, both permanent and temporary works, and provide information regarding the significant risks to all parties involved in the project.

Designers when preparing or modifying a design are required to avoid foreseeable risks to the health and safety of any person involved with:

- Constructing the design;
- Operating the constructed design;
- Maintaining the constructed design;
- Clearing the constructed design;
- Future construction/alteration of the constructed design; and
- The ultimate demolition/dismantling of the constructed design.

AMC UK's design planning will include design Input Reviews and Design Change Control, to ensure co-operation and co-ordination of the works with the Designer and/or other Designers is adequately achieving requirements.

All temporary works required will be assessed and where they are found to give rise to significant risk that cannot be designed out by use of the proprietary structures, full design and calculation of the temporary works will be carried out.

Where the Designer identifies significant risk, these risks will be included within the relevant method statements with the associated control measures.

SECTION 10 - SITE CONTROLS

10.1. Site Security

The objective of security is to ensure business continuity and to minimise damage and theft by preventing and/or minimising the impact of security incidents. Sirius Minerals' Site Security Procedure and Customer Care Policy will apply.

Sirius Minerals is providing site security, including a secure perimeter fence and a security watchman at the entrance security cabin. AMC UK will control its designated work area with the most senior representative on site being responsible for security.

Operations will typically be 24 hours per day, 7 days per week. If the site is vacant, AMC UK will secure the work area by locking up welfare facilities, locking equipment, barricading active works which pose a risk, etc.

Where excavations are to be left open at night suitable covers will be positioned over the top of the excavation and/or barriers or fencing. The level of protection shall be assessed and resourced by the Package Manager for each works area.

The following methods of site security will be implemented as detailed below. Although open to change as the works progress or conditions dictate, all actions and control methods must be followed and regularly reviewed throughout the contract to minimise the risk of unauthorised entry to / theft from the site.

Item	Methods of Control	Option Selected	Organisation with the Role / Responsibility
Allocation of Responsibilities	Shift Supervisor	YES	AMC UK and Sirius Minerals
Police Liaison	Emergency contact details provided	YES	Via Sirius Minerals
Access	Sirius Minerals Security Watchman	YES	Controlled by Sirius Minerals
Perimeter Protection	Anti Climb Fencing	YES	Controlled by Sirius Minerals
Compound Protection	Heras Fencing	YES	AMC UK
Control Procedures for Goods and Materials	Authorised signatories Secure storage areas	YES	AMC UK
Security of Heavy Plant Items	Locks	YES	AMC UK and Sub-contractors
Security of Small Plant	Site register Secure stores	YES	AMC UK and Sub-contractors
Security Lighting	Sensory Controlled Time Switch	YES	AMC UK and Sub-contractors
Security Containers	Steel construction	YES	AMC UK and Sub-contractors
Site Office Accommodation	Steel construction	YES	AMC UK and Sub-contractors
Office Equipment	Lockable offices	YES	AMC UK and Sub-contractors
Keys	Access restricted Secure key box	YES	AMC UK and Sub-contractors
Security Guarding	Out of hours	YES	Sirius Minerals
Alarm system	Monitored	NO	
CCTV	Monitored with response	NO	
Site closure	Contact details to police Roster for site visit	YES	AMC UK and Sirius Minerals
Car/Van parking	Designated area within compound	YES	Sirius Minerals
General	Advice to staff Discipline implications Advice to sub-contractors Safety meetings Warning notices	YES	AMC UK and Sub-contractors

10.1.1. Site Fencing

Anti-climb fencing (2 m in height) will be installed around the site perimeter (installed and managed by Sirius Minerals). Internal temporary Heras fencing will be installed around active work areas (installed and maintained by AMC UK). All fencing will be checked regularly to ensure no breach or damage has occurred (by each responsible party). If a breach or damage is discovered, it will be reported immediately and measures taken to re-secure the site.

An access gate and manned security cabin will be implemented by Sirius Minerals at the south of the site from B1416. This will permit only authorised access, as required.

10.2. Site Visitors

On arrival at the site entrance, the AMC UK Package Manager / Site Supervisor will be notified of the visitor's presence. The site visitor will report to the AMC UK Package Manager/Site Supervisor and a site safety induction will be given. The pre-commencement safety questionnaire will be completed so that any special requirements can be dealt with. All visitors must be recorded on the sign in / sign out register. PPE as prescribed in the CPHSP will be worn by all visitors. Visitors are to be escorted on site and will not be allowed within close proximity to any plant in operation.

10.3. Site Induction, Information and Training

Information will be provided by AMC UK to all personnel on the site via a Site Induction and subsequent Toolbox Talks. Records of site inductions will be maintained in the project office in the sign in / sign out register.

The pre-commencement safety questionnaire will be given out by the Package Manager or designate and reviewed so that any special requirements can be dealt with.

10.3.1. On-Site Training

AMC UK will ensure that its employees have received appropriate information, instruction and training.

Information and instruction are delivered by Daily pre shift briefing, Toolbox Meetings and Weekly Meetings. All work/task specific training will be given by AMC UK or other suitable bodies nominated by AMC UK.

Project specific awareness training will be arranged as necessary by AMC UK as identified by the Designer, the Health and Safety Manager, Site Management and/or Safety Advisors.

10.4. Provision of Welfare Facilities

Welfare Facilities (meeting the minimum required by CDM 2015 as a guideline) will be provided by AMC UK and its subcontractors. The facilities will be regularly serviced and maintained. These will include changing facilities, canteen/mess room and adequate toilet facilities on site.

All offices and site accommodation are non-smoking, in accordance with the Smoking Policy and current workplace regulations.

10.4.1. Site Notice Boards

A site notice board will be erected at the following locations:

- Woodsmith Mine Site Office(s).
- Woodsmith Mine Canteen / Welfare building(s).

The notice boards will detail the names and contact details of the key personnel on site, including the Package Manager and the AMC UK Environmental and Health and Safety Managers and will include details of how to raise a concern or issue. In addition the details of relevant stakeholders and telephone numbers will be included on the notice boards. The notice boards will be reviewed on a regular basis to ensure that the information remains up to date.

10.4.2. Illustrated Mandatory and Advisory Health & Safety Information to be Displayed On-site

POSTER/DOCUMENT c = Compulsory, o = Optional / Site Specific	LOCATION	
	Site Office	Welfare Units
Accident/Incident Flowchart	c	o
Accident book (GS0309)	c	o
Bad Vibrations Poster (Enfield GS1215)	o	c
Cabin Electrical certificates	c	c
Confined Spaces Poster	o	o
Control of Substances Hazardous to Health Poster (Enfield GS1129)	o	c
Construction Site Safety Checklist Poster (Enfield GS1246)	o	c
COSHH Assessments (Current)	c	o
COSHH Symbols	c	o
Details of emergency services	c	c
Emergency Response Plan	c	c
Emergency Resuscitation (Enfield GS1103)	o	c
Employers Liability Insurance Certificate	c	
Fire Action Sign	c	c
Control of Noise at Work Poster (Enfield GS1127)	o	c
Working at Height Poster (Enfield GS1242)	o	o
Health and Safety and environmental contacts	c	c
Health and Safety Law poster	c	c
AMC UK Policies	c	o
Know Where to Get First Aid Poster (Enfield S472S)	c	c
Manual Handling Operations Poster (Enfield GS1123)	o	c
Method Statements (current)	c	o
Brother's Keeper Cards	c	c
Permits (current)	c	o
Representatives of Employee Safety	c	c
Risk Assessment (current)	o	o
Site Layout Drawing	c	c
Site Register of Weekly Inspections	c	o
Site Rules	c	c

10.4.3. Illustrated Mandatory and Advisory Environmental Information to be Displayed On-site

The following information is to be displayed on notice boards where applicable:

POSTER/DOCUMENT c = compulsory, o = optional / site specific	LOCATION	
	Site Cabin	Welfare units
Emergency Contact Numbers	c	c
Health & Safety and Environmental Alerts (Current)	c	c
Environmental Emergency Preparedness Plan	c	o
Emergency Response Plan	c	o
Accident and Emergency (A&E) Hospital and Route	c	c
Environmental Aspects and Impacts Assessment	c	o
Brother's Keeper Cards	c	c

10.4.4. Emergency Procedures

The following outlines the Emergency Procedures prepared for the project.

Emergency Procedures	Required	Display Location
Environmental Emergency Preparedness Plan	✓	Office
Emergency Response Plan	✓	Office
Fire Plan	✓	Office
Accident and Emergency (A&E) Hospital and Route	✓	Office

10.4.5. Deliveries and Logistics

Materials requiring storage prior to use, will be placed in designated storage areas as close as possible to final point of use. Material/equipment that is prone to damage by weather or contamination will be given appropriate protection. Packaging will not be removed, other than to verify condition on delivery, until material/equipment is to be used/installed. Storage of materials shall be undertaken in consideration with relevant environmental planning to ensure no pollution. Newly installed material/equipment will be given appropriate protection to prevent unintentional damage.

Any problems recorded against any supplier will use the non-conformance system which is part of the supplier review process.

10.4.5.1. Delivery Routes

The routes used by HGVs will be consistent with those identified in the planning permission. All HGVs will all depart from the Welfare Access onto the B1416 east towards the A171 avoiding Ruswarp. At the junction of the B1416 with the A171, the primary haul route will be north on the A171 towards Teesside via Whitby.

In addition to the primary haul route, two local quarries were also identified as potentially being suitable to supply aggregate, therefore two secondary haul routes are also permitted to serve these quarries. From the junction of the A171 and B1416 HGVs heading towards the quarry at Wykeham will head south on the A171 towards Scarborough before travelling west along the A170 to Wykeham. HGVs heading towards the quarry at Pickering will head north from the junction of the A171 and B1416 towards Whitby, to the west of Whitby HGVs will then head south on the A169 towards Pickering.

All suppliers and drivers will be given a toolbox talk at their premises prior to their first delivery. They will be advised on the permitted and prohibited HGV routes, as well as the actions which will be taken if they deviate from the permitted routes.

To help the public distinguish Phase 4 construction traffic from other traffic on the network and therefore effectively report any concerns, each vehicle would be required to display a unique identifier within the window of the cab (the Sirius Minerals logo).

In addition to the toolbox talks drivers will also be issued with information packs. The packs will be a convenient size so it can be stored in a truck cab and include key information on:

- The unique identifier to display in the window.
- A plan of showing the delivery routes.
- Details of procedures for dealing with emergencies.
- Details of driver training requirements.
- Details of disciplinary measures for non-compliance.

10.4.5.2. Penalty System for Breaches of Traffic Management Requirements

Please refer to the Construction Traffic Management Plan (CTMP) concerning breaches and penalties.

APPENDIX A

DESIGN DRAWINGS

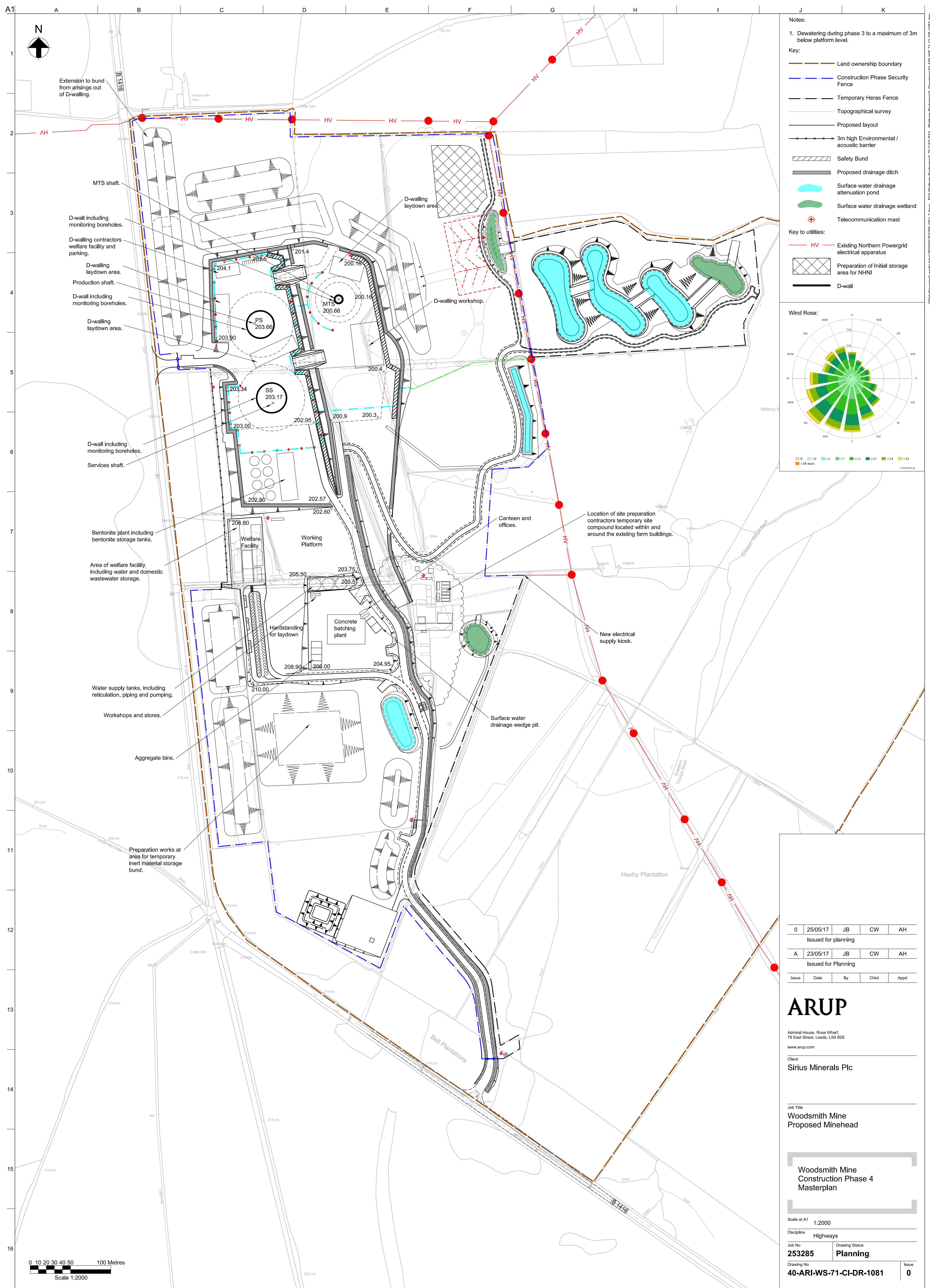

- Notes:
- Dewatering during phase 3 to a maximum of 3m below platform level.
- Key:
- Land ownership boundary
 - Construction Phase Security Fence
 - Temporary Heras Fence
 - Topographical survey
 - Proposed layout
 - 3m high Environmental / acoustic barrier
 - Safety Bund
 - Proposed drainage ditch
 - Surface water drainage attenuation pond
 - Surface water drainage wetland
 - Telecommunication mast
- Key to utilities:
- HV Existing Northern Powergrid electrical apparatus
 - Preparation of initial storage area for NHNI
 - D-wall

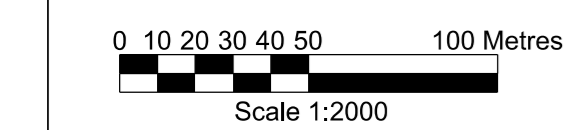
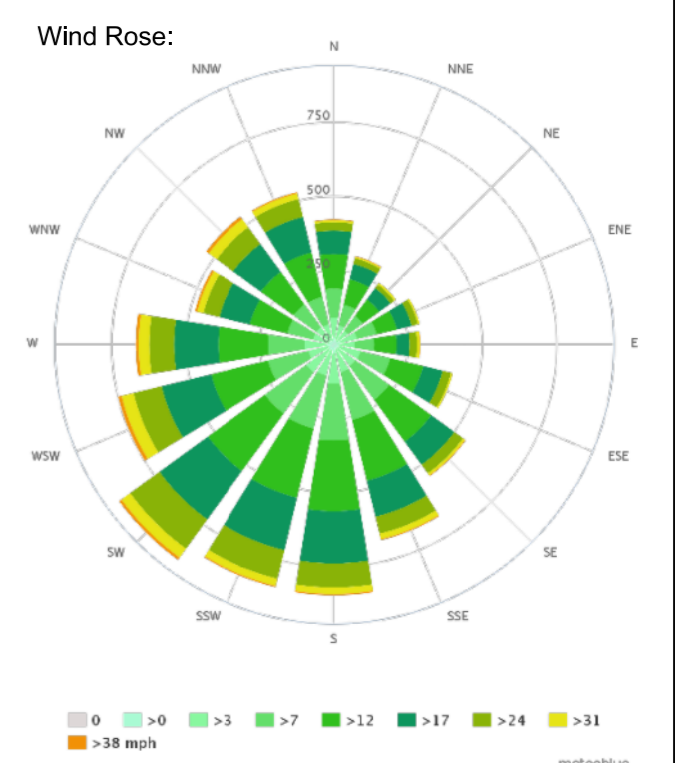

0	25/05/17	JB	CW	AH
Issued for planning				
A	23/05/17	JB	CW	AH
Issued for Planning				
Issue	Date	By	Chkd	Appd

ARUP

Admiral House, Rose Wharf,
78 East Street, Leeds, LS9 8EE
www.arup.com

Client
Sirius Minerals Plc

Job Title
**Woodsmith Mine
Proposed Minehead**

**Woodsmith Mine
Construction Phase 4
Masterplan**

Scale at A1 1:2000

Discipline **Highways**

Job No **253285** Drawing Status **Planning**

Drawing No **40-ARI-WS-71-CI-DR-1081** Issue **0**

The information, specifications and drawings of this document are valid for the construction of the project. It is the responsibility of the contractor to ensure that the information is correct and that the construction is carried out in accordance with the drawings. The contractor shall be responsible for any errors or omissions. The contractor shall be responsible for any damage to the project. The contractor shall be responsible for any safety issues.

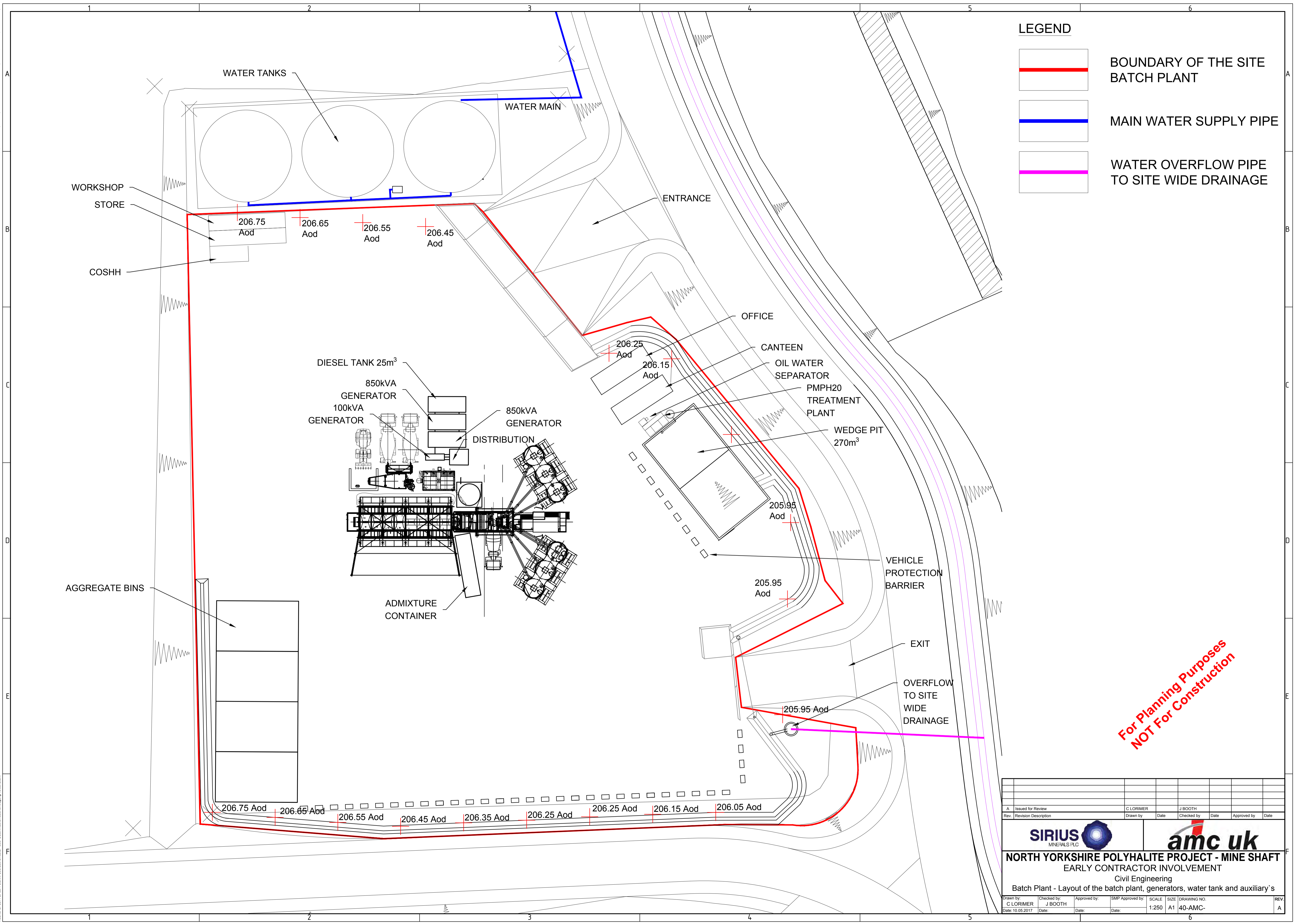

LEGEND

- BOUNDARY OF THE SITE BATCH PLANT
- MAIN WATER SUPPLY PIPE
- WATER OVERFLOW PIPE TO SITE WIDE DRAINAGE

For Planning Purposes
 NOT For Construction

<table border="1" style="width: 100%; border-collapse: collapse;"> <tr> <td style="width: 50%;">A</td> <td>Issued for Review</td> <td>C LORIMER</td> <td>J BOOTH</td> </tr> <tr> <td>Rev</td> <td>Revision Description</td> <td>Drawn by</td> <td>Date</td> </tr> <tr> <td></td> <td></td> <td>Checked by</td> <td>Date</td> </tr> <tr> <td></td> <td></td> <td>Approved by</td> <td>Date</td> </tr> </table>	A	Issued for Review	C LORIMER	J BOOTH	Rev	Revision Description	Drawn by	Date			Checked by	Date			Approved by	Date	 NORTH YORKSHIRE POLYHALITE PROJECT - MINE SHAFT EARLY CONTRACTOR INVOLVEMENT Civil Engineering Batch Plant - Layout of the batch plant, generators, water tank and auxiliary's
A	Issued for Review	C LORIMER	J BOOTH														
Rev	Revision Description	Drawn by	Date														
		Checked by	Date														
		Approved by	Date														
Drawn by: C LORIMER Checked by: J BOOTH Date: 10.05.2017	Approved by: SMP Approved by: J BOOTH Date: _____ SCALE: 1:250 SIZE: A1 DRAWING NO.: 40-AMC- REV: A																

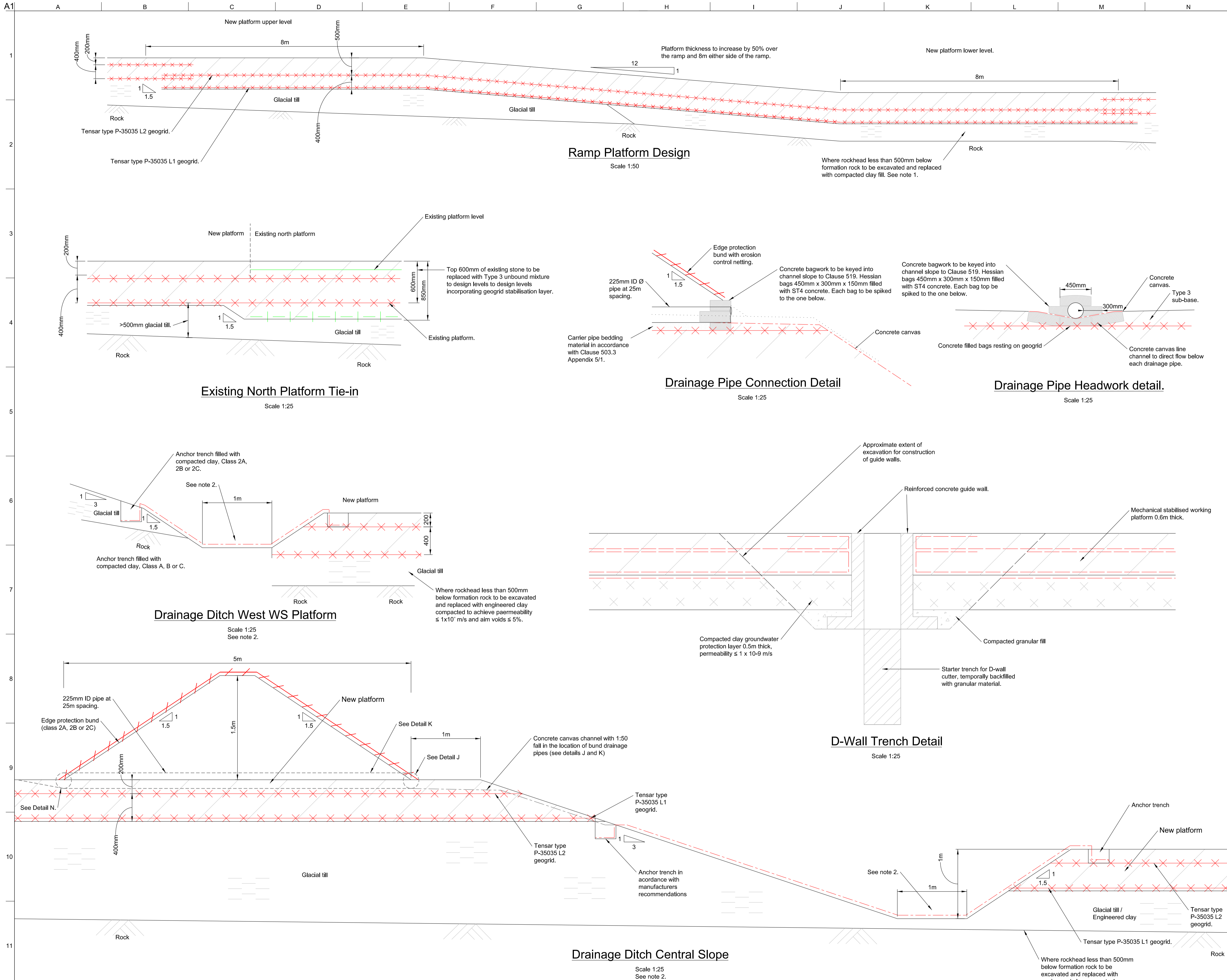

- Notes:
- Where glacial till is less than 500mm thick, underlying rock to be excavated and replaced with compacted clay to achieve a permeability $\leq 1 \times 10^{-9}$ m/s and air voids $\leq 5\%$. Glacial till thickness to be confirmed during construction with trial pits at 25m c/c.
 - Concrete canvas to be installed in accordance with the manufacturers guidance.
 - Formation soft spots to be excavated and replaced with compacted acceptable material.
 - Edge protection bund to be hydroseeded.

- Key:
- Tensar geogrid
 - Concrete canvas (CC8 or equivalent approved)
 - Erosion protection netting (Terracoir 400 or equivalent approved)
 - 225mm ID drainage pipe
 - Type 3 unbound mixture (clause 805)
 - Class 2A - 2C
 - Glacial till
 - Rock
 - Engineered Clay Fill

2	25/05/17	JB	CW	AH
Issue For Planning				
1	23/05/17	JB	CW	AH
Issue for Planning				
0	31/03/17	TC	CW	AH
Issue for Planning				
A	30/03/17	TC	CW	AH
Draft				
Issue	Date	By	Chkd	Appd

ARUP
 Admiral House, Rose Wharf,
 79 East Street, Leeds, LS9 8EE
 www.arup.com

Client
Sirius Minerals Plc

Job Title
Woodsmith Mine Proposed Minehead

Earthworks Sections Tie-in Details Sheet 1 of 2

Scale at A1: 1:50

Discipline	Earthworks
Job No	253285
Drawing Status	Planning
Drawing No	40-ARI-WS-71-CI-DR-1060
Issue	2

The reproduction, distribution and utilization of this document as well as the communication of its contents to others without expressed authorization is prohibited. Offenders will be held liable for the payment of damages. All rights reserved in the event of the grant of a patent, utility model or design.

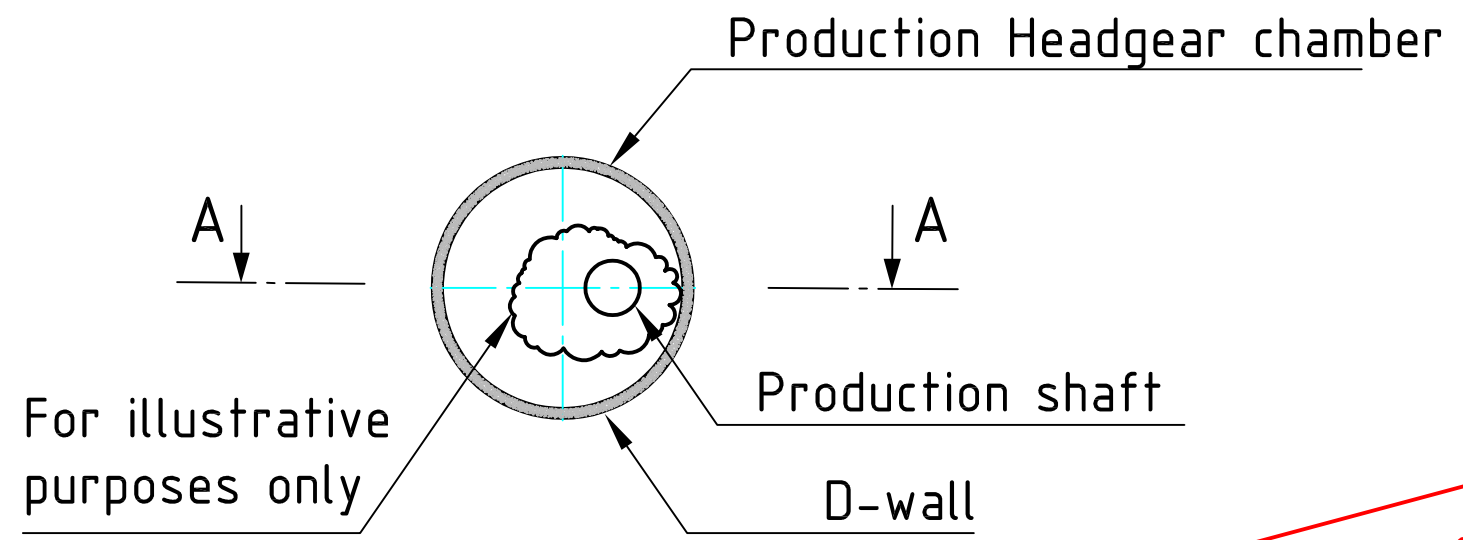
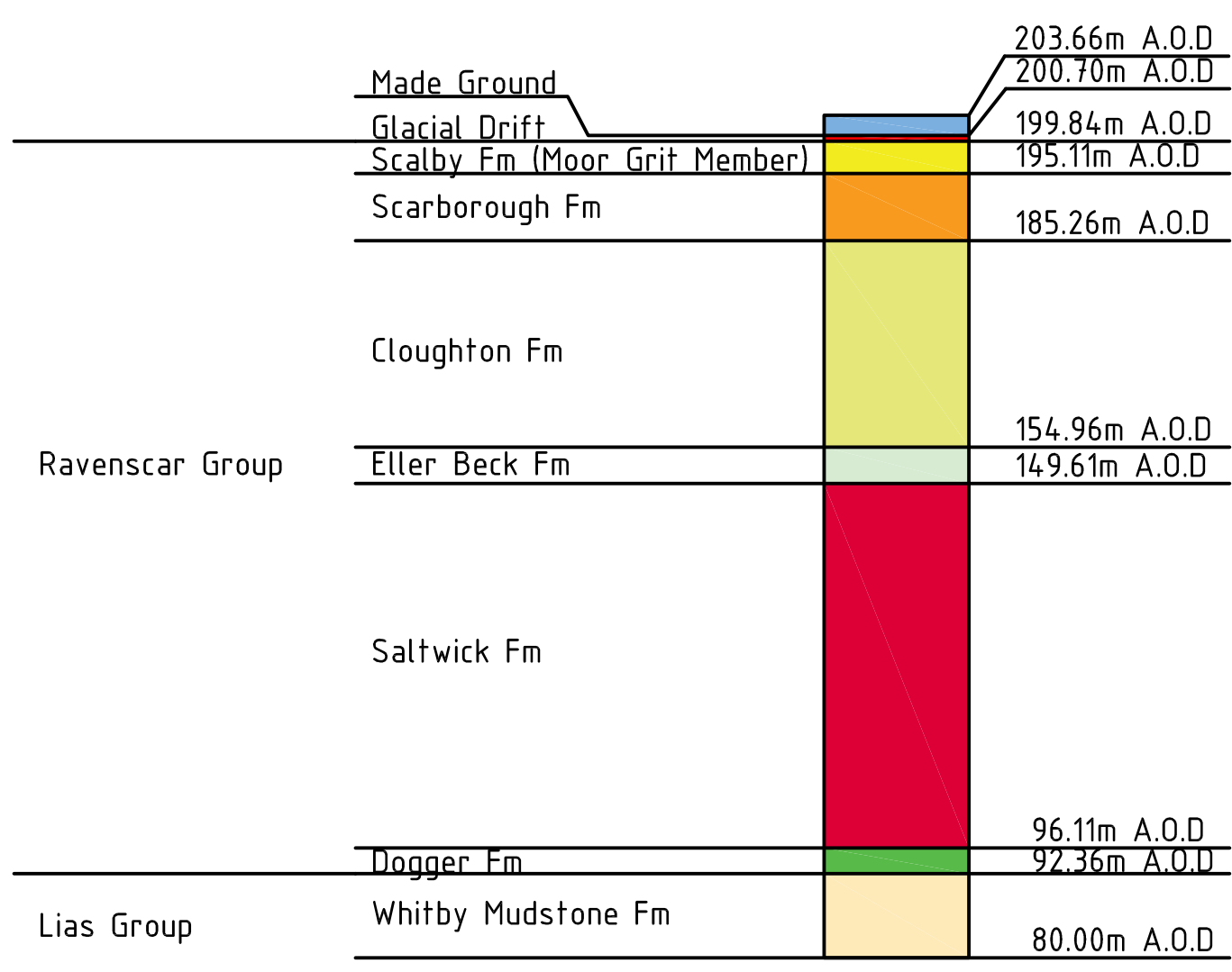
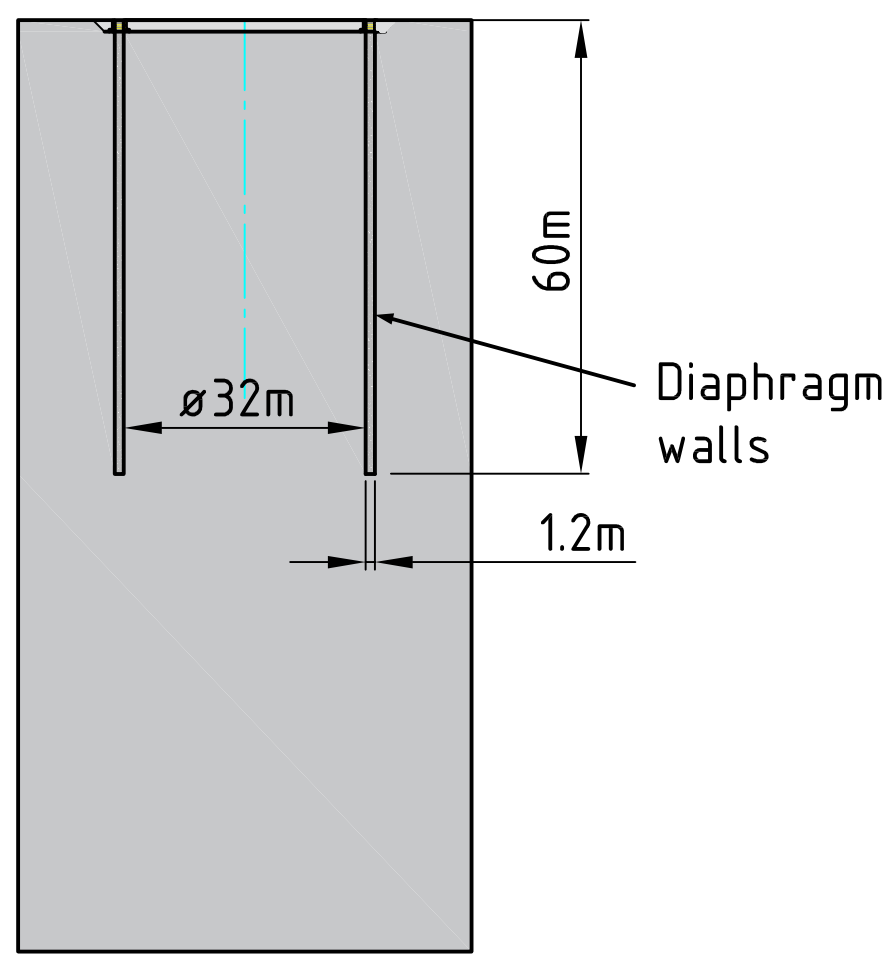

FOR PLANNING PURPOSES
NOT FOR CONSTRUCTION

Rev.	Revision Description	Drawn by	Date	Checked by	Date	Approved by	Date
A	Issued for planning	Sancho Calderón	23.05.2017	Hentrich	24.05.2017	Voll	24.05.2017



NORTH YORKSHIRE POLYHALITE PROJECT - MINE SHAFT
EARLY CONTRACTOR INVOLVEMENT
CIVIL ENGINEERING
Production Headgear Chamber Cross Section

Drawn by:	Checked by:	Approved by:	SMP Approved by:	SCALE	SIZE	DRAWING NO.	REV.
Sancho Calderón	Hentrich	Voll		1:1000	A3	40-AMC-WS-11-CI-DR-1901	0
Date: 23.05.2017	Date: 24.05.2017	Date: 24.05.2017	Date:				

Weitergabe sowie Vervielfältigung dieses Dokuments, Verwertung und Mitteilung seines Inhalts sind verboten, soweit nicht ausdrücklich gestattet. Zuwiderhandlungen verpflichten zu Schadenersatz. Alle Rechte für den Fall der Patent-, Gebrauchsmuster- oder Geschmacksmusterertragung vorbehalten.

The reproduction, distribution and utilization of this document as well as the communication of its contents to others without expressed authorization is prohibited. Offenders will be held liable for the payment of damages. All rights reserved in the event of the grant of a patent, utility model or design.

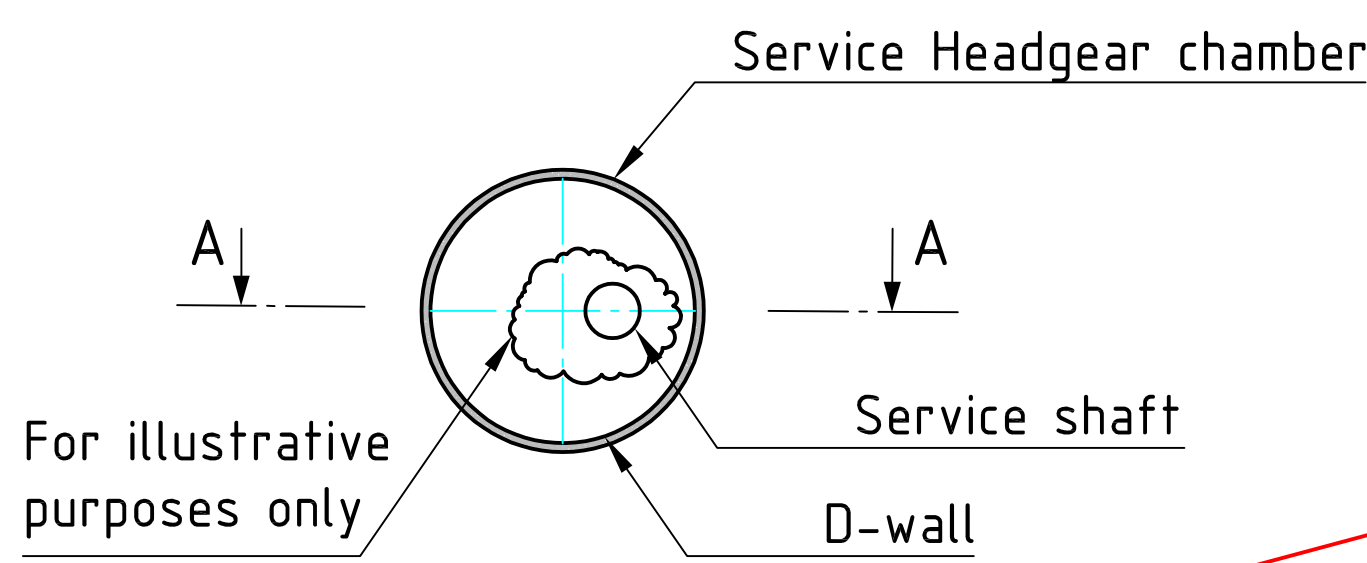
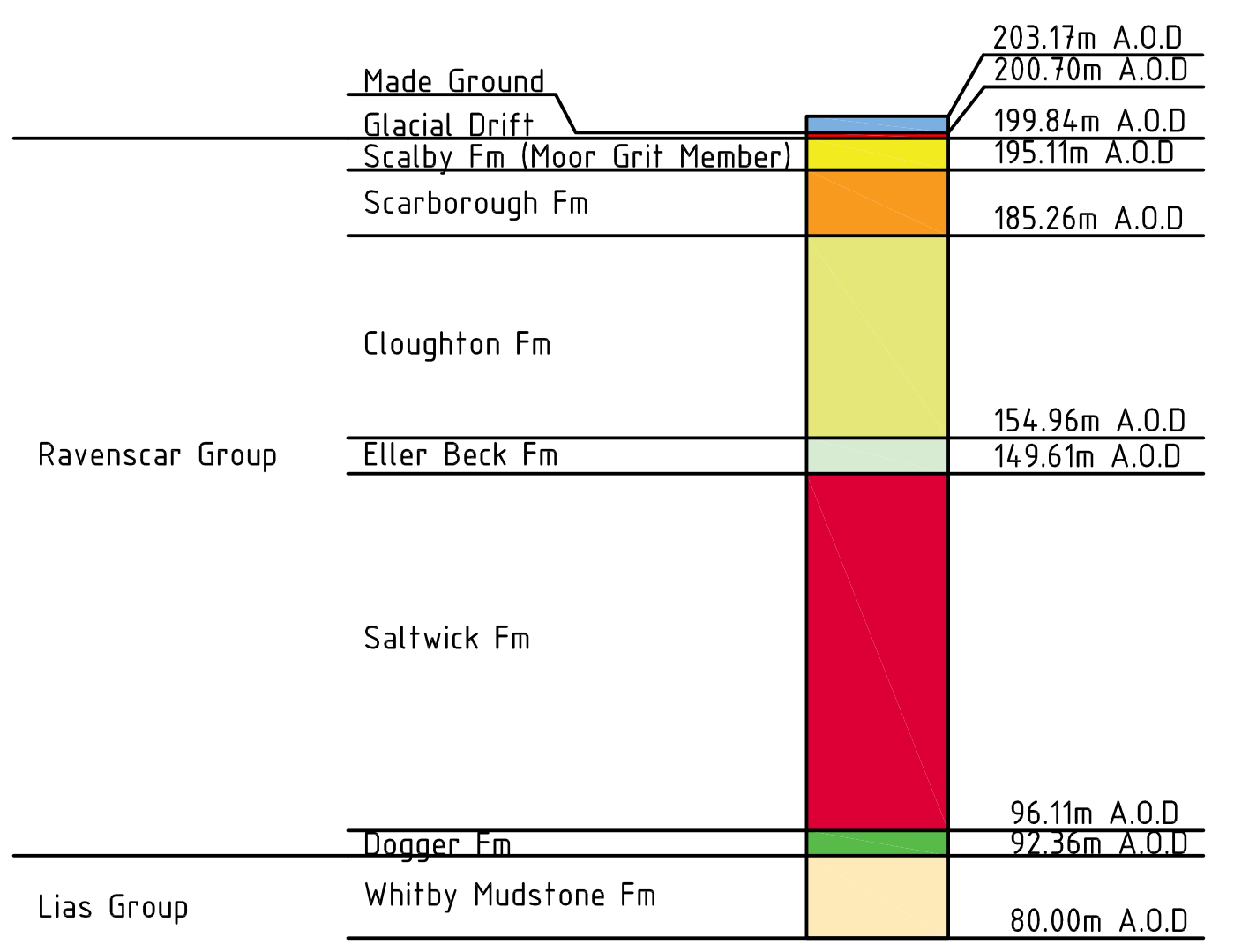
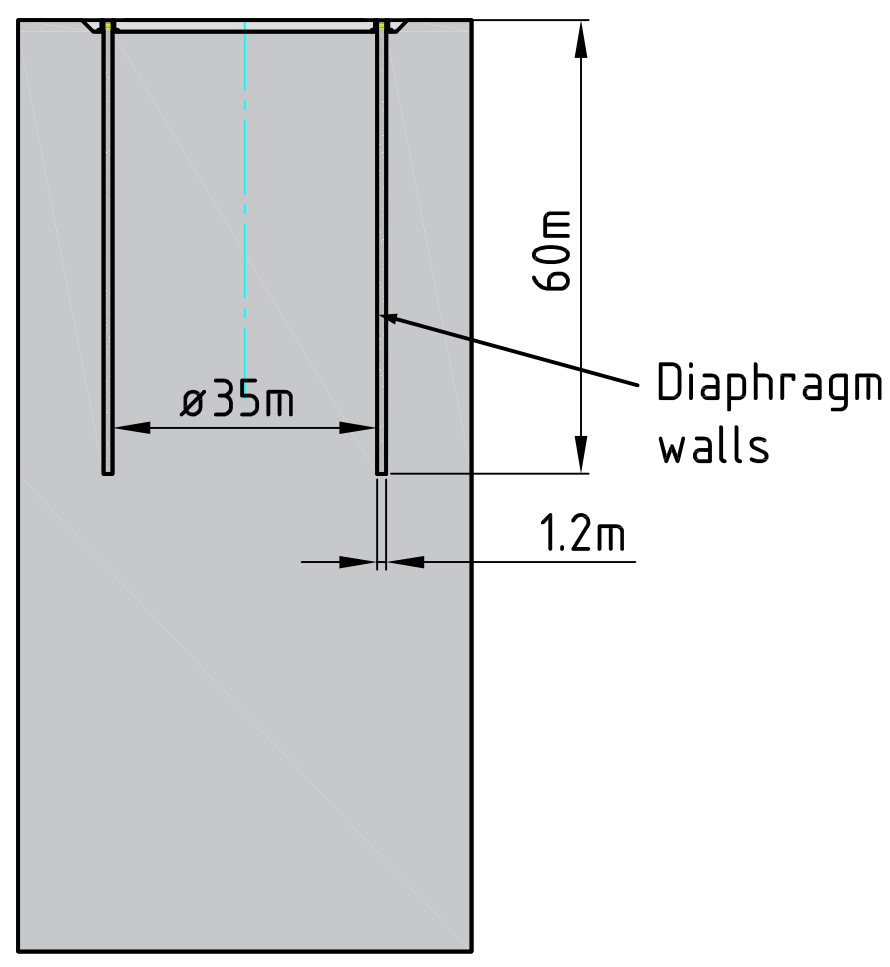

FOR PLANNING PURPOSES
NOT FOR CONSTRUCTION

Rev.	Description	Drawn by	Date	Checked by	Date	Approved by	Date
A	Issued for Planning	Sancho Calderón	23.05.2017	Hentrich	24.05.2017	Voll	24.05.2017



NORTH YORKSHIRE POLYHALITE PROJECT - MINE SHAFT
EARLY CONTRACTOR INVOLVEMENT
CIVIL ENGINEERING
SERVICE HEADGEAR CHAMBER CROSS SECTION

Drawn by:	Checked by:	Approved by:	SMP Approved by:	SCALE	SIZE	DRAWING NO.	REV.
Sancho Calderón	Hentrich	Voll		1:1000	A3	40-AMC-WS-12-CI-DR-1901	0
Date: 23.05.2017	Date: 24.05.2017	Date: 24.05.2017	Date:				

Weitergabe sowie Vervielfältigung dieses Dokuments, Verwertung und Mitteilung seines Inhalts sind verboten, soweit nicht ausdrücklich gestattet. Zuwiderhandlungen verpflichten zu Schadenersatz. Alle Rechte für den Fall der Patent-, Gebrauchsmuster- oder Geschmacksmusteranmeldung vorbehalten.

The reproduction, distribution and utilization of this document as well as the communication of its contents to others without expressed authorization is prohibited. Offenders will be held liable for the payment of damages. All rights reserved in the event of the grant of a patent, utility model or design.

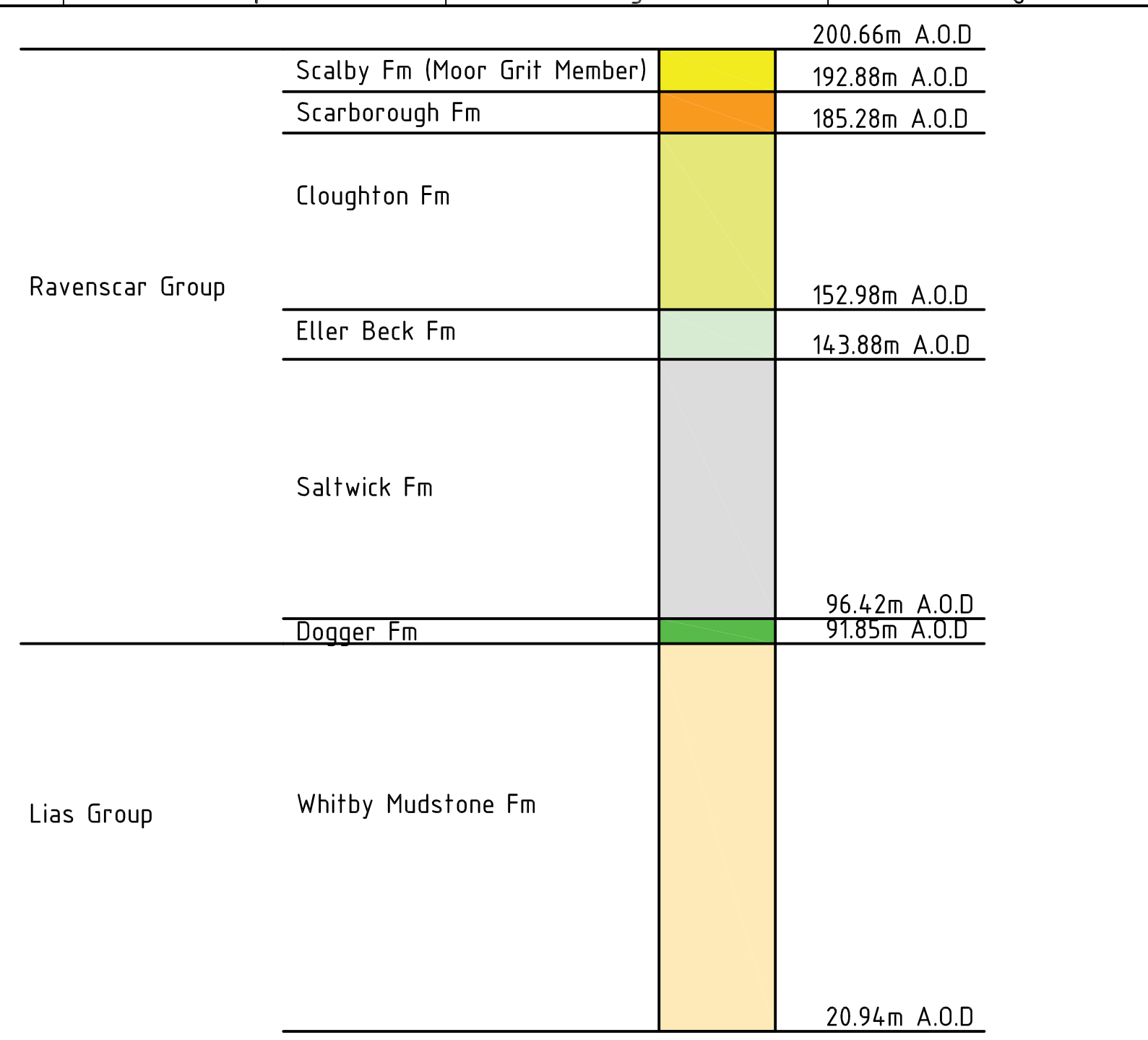
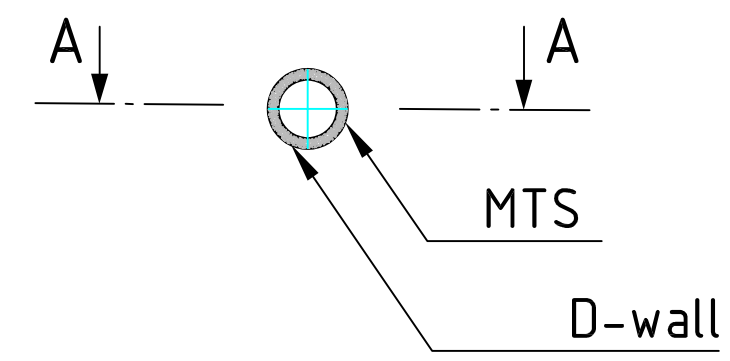
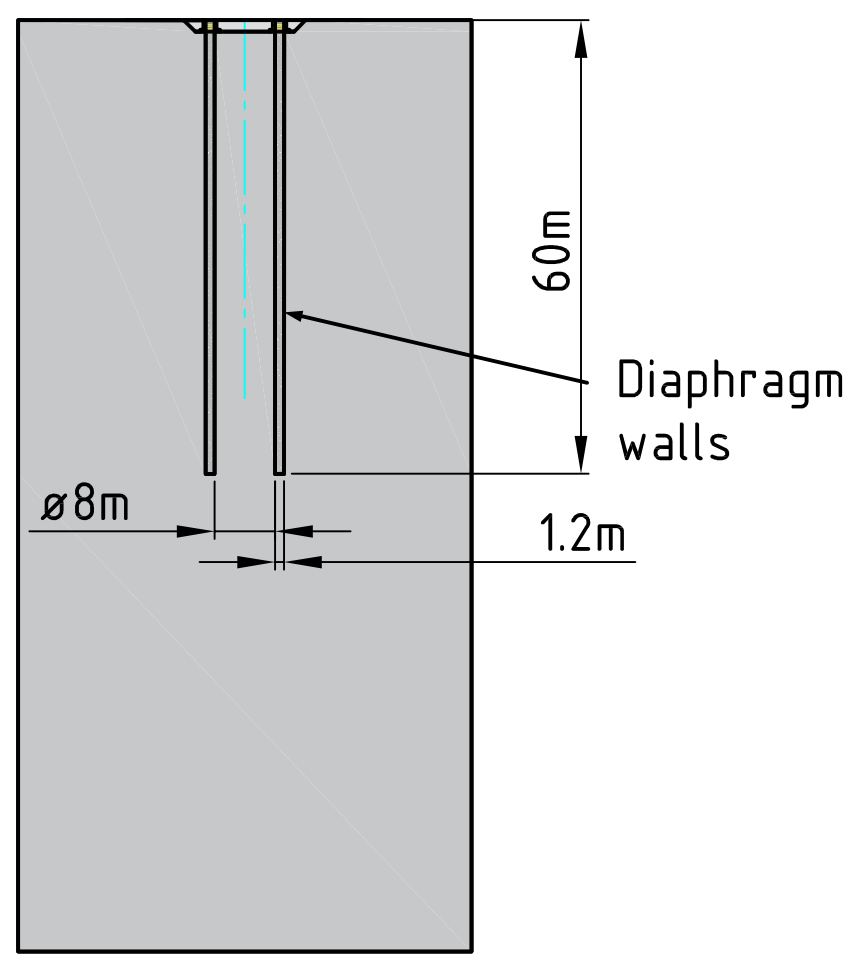

FOR PLANNING PURPOSES
NOT FOR CONSTRUCTION

Rev.	Revision Description	Drawn by	Date	Checked by	Date	Approved by	Date
A	Issued for Planning	Sancho Calderón	23.05.2017	Hentrich	24.05.2017	Voll	24.05.2017



NORTH YORKSHIRE POLYHALITE PROJECT - MINE SHAFT
EARLY CONTRACTOR INVOLVEMENT
CIVIL ENGINEERING
MTS D-Wall Cross Section

Drawn by: Sancho Calderón	Checked by: Hentrich	Approved by: Voll	SMP Approved by: Date:	SCALE 1:1000	SIZE A3	DRAWING NO. 40-AMC-WS-13-CI-DR-1901	REV. 0
------------------------------	-------------------------	----------------------	---------------------------	-----------------	------------	--	------------------

Weitergabe sowie Vervielfältigung dieses Dokuments, Verwertung und Mitteilung seines Inhalts sind verboten, soweit nicht ausdrücklich gestattet. Zuwiderhandlungen verpflichten zu Schadenersatz. Alle Rechte für den Fall der Patent-, Gebrauchsmuster- oder Geschmacksmusteranmeldung vorbehalten.

Top View Guide Wall -Headgear Chamber - Production Shaft

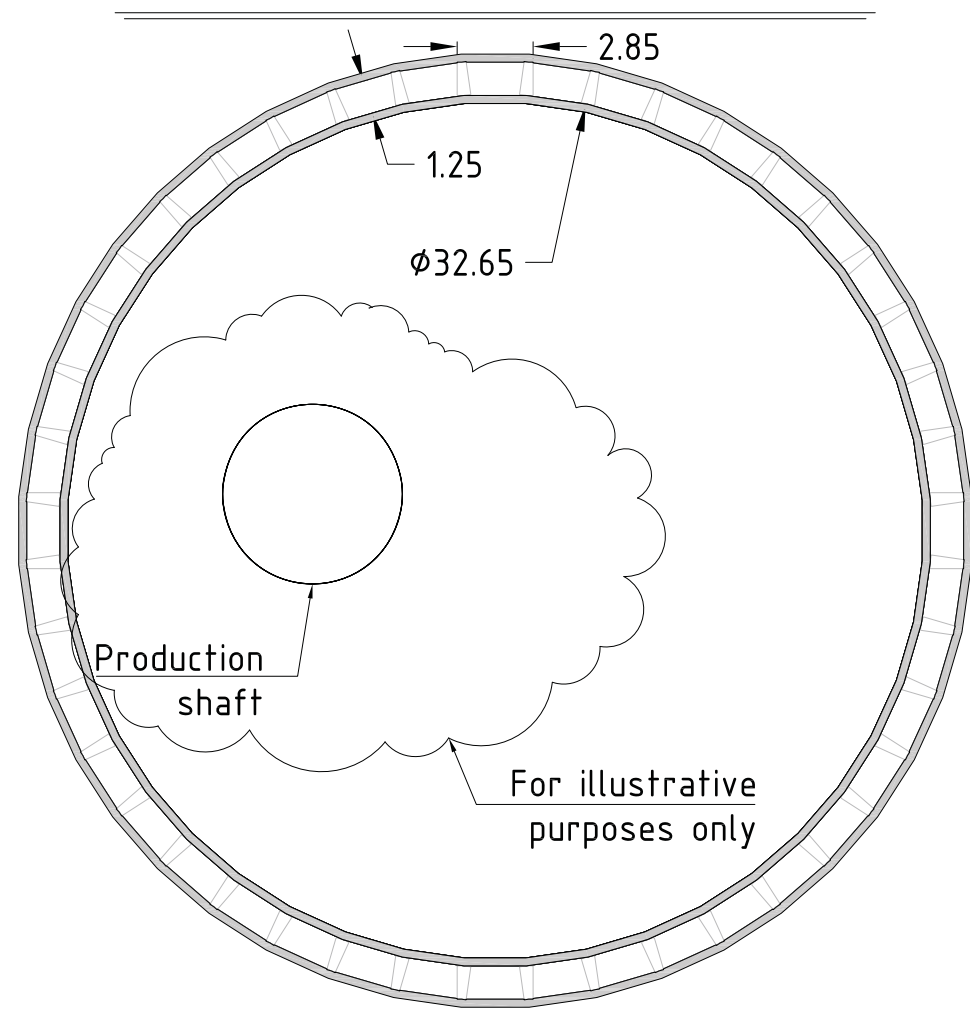

Top View Guide Wall - Headgear Chamber - Service Shaft

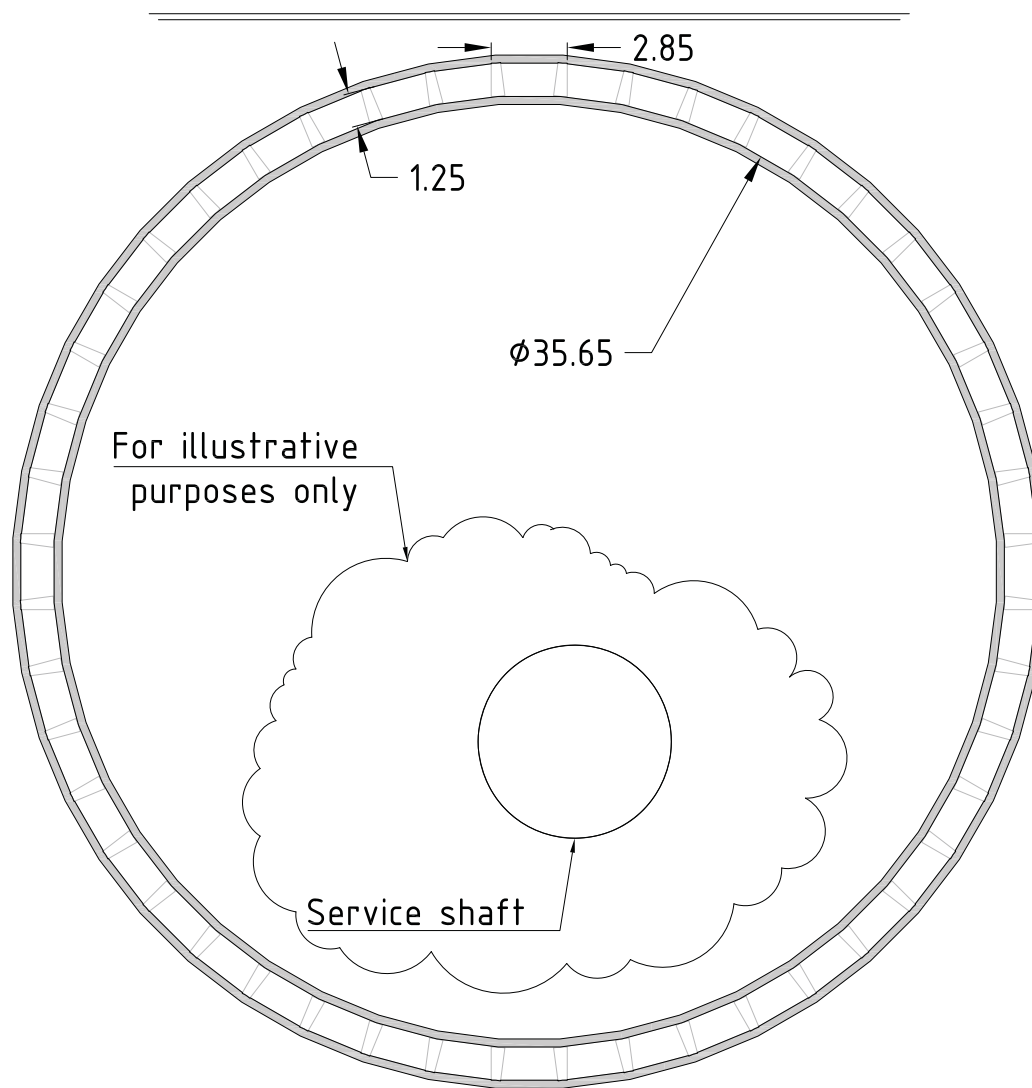

Top View Guide Wall MTS / TBM Shaft

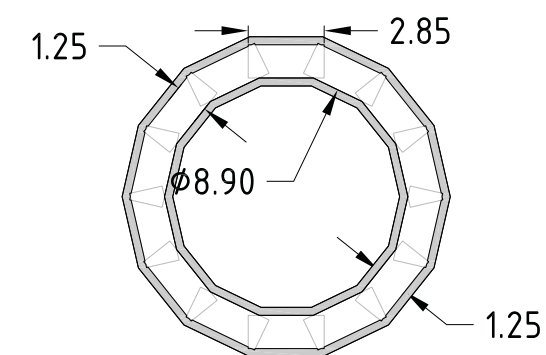

FOR PLANNING PURPOSES
NOT FOR CONSTRUCTION

Revision		Drawn by	Date	Checked by	Date	Approved by	Date
B	Issued for Mining	Burke	24.05.2017	Henrich	24.05.2017	V&R	24.05.2017
A	Issued for SM Review	Jakob	19.05.2017	Henrich	19.05.2017	Dr. Franz	19.05.2017
No.	Revision Description	Drawn by	Date	Checked by	Date	Approved by	Date
NORTH YORKSHIRE POLYHALITE PROJECT - MINE SHAFT EARLY CONTRACTOR INVOLVEMENT CIVIL ENGINEERING Preliminary guide wall layout for the headgear chamber and for the MTS shaft							
Drawn by	Checked by	Approved by	Scale	Size	Drawing No.	Rev	
Jakob	Henrich	Dr. Franz	1:100	A0	40-AMC-WS-71-CH-DR-0079	0	

Top View Panel Layout of the Headgear Chamber at the Production Shaft

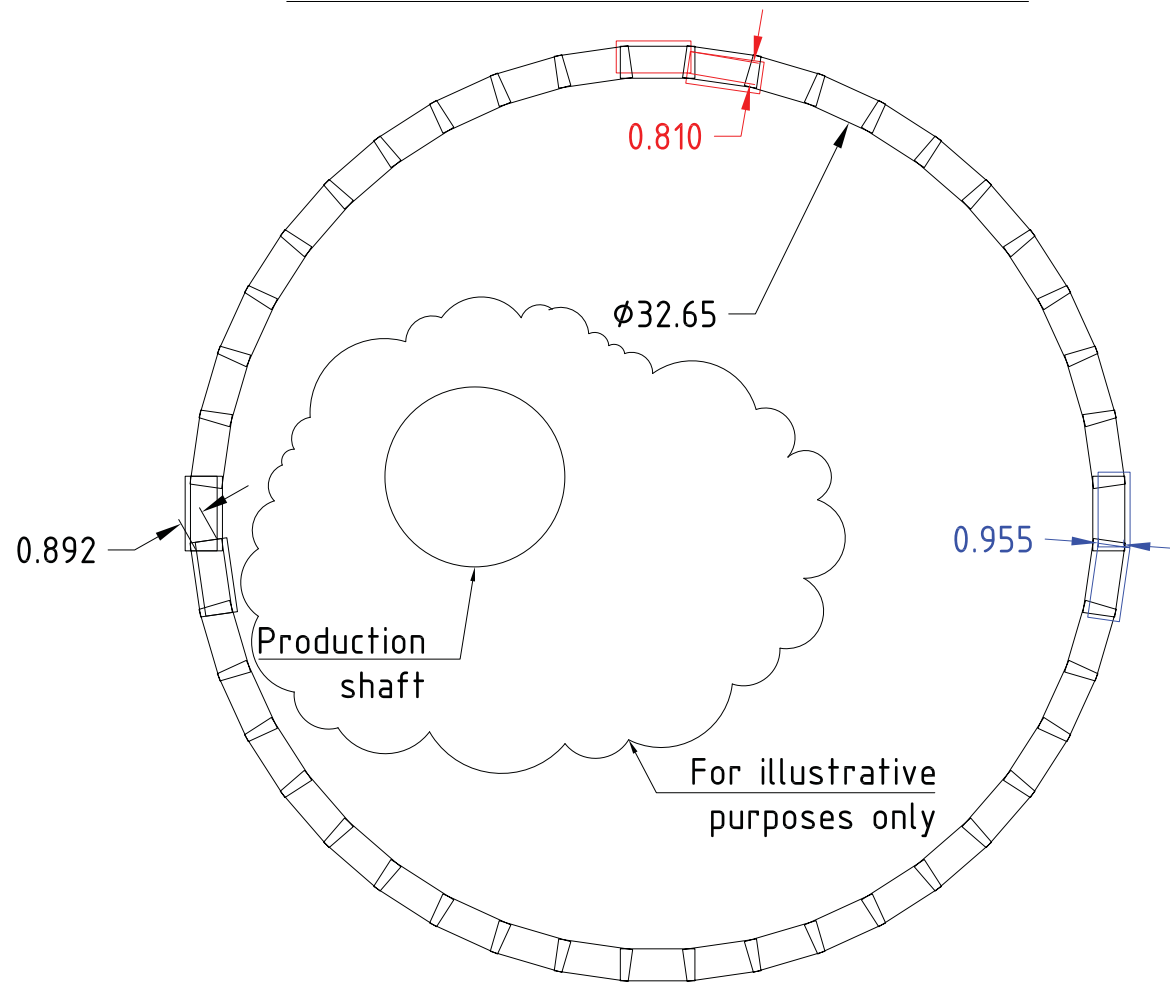

Top View Panel Layout of Headgear Chamber at the Service Shaft

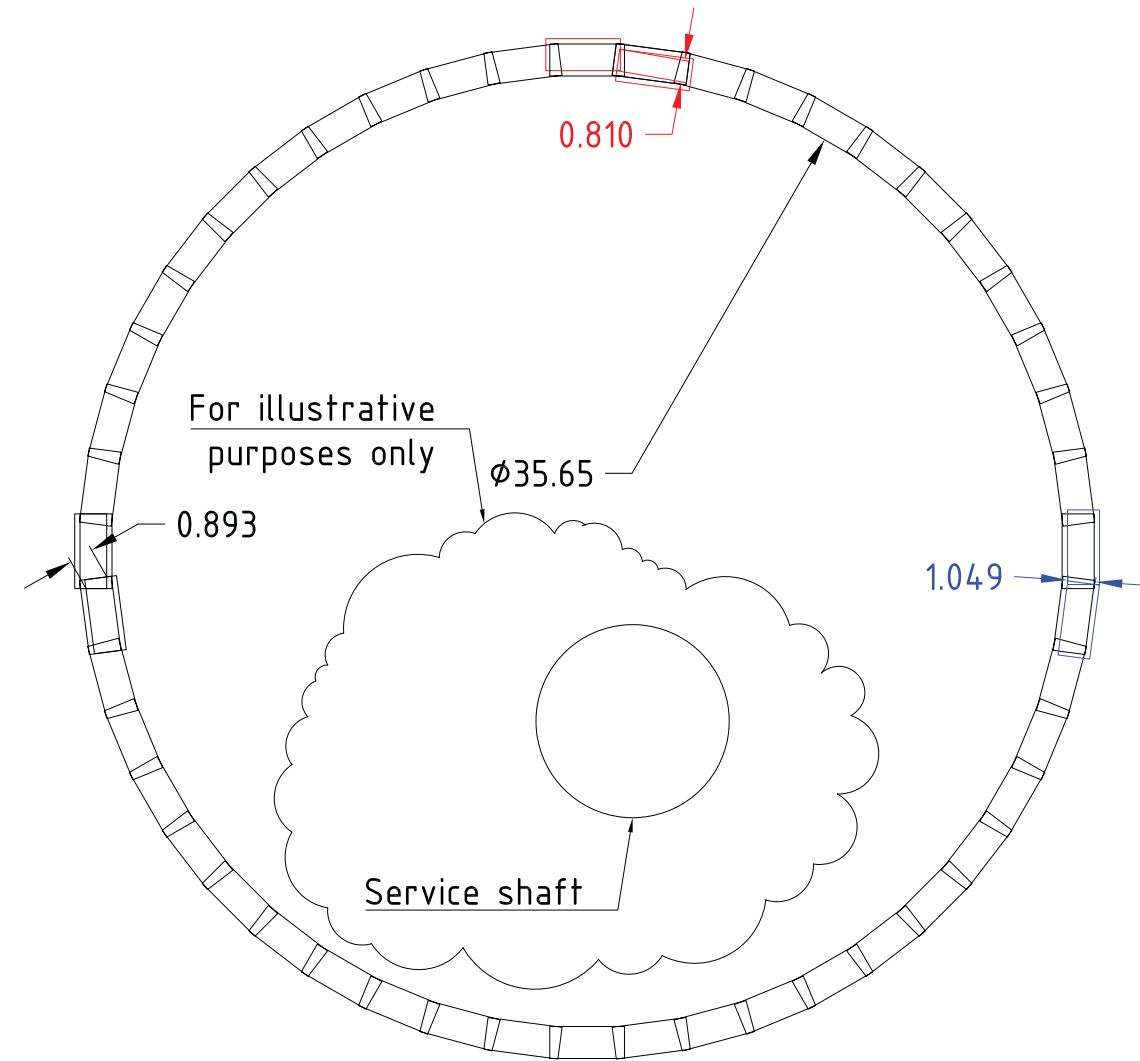

Top View Panel Layout MTS / TBM Shaft

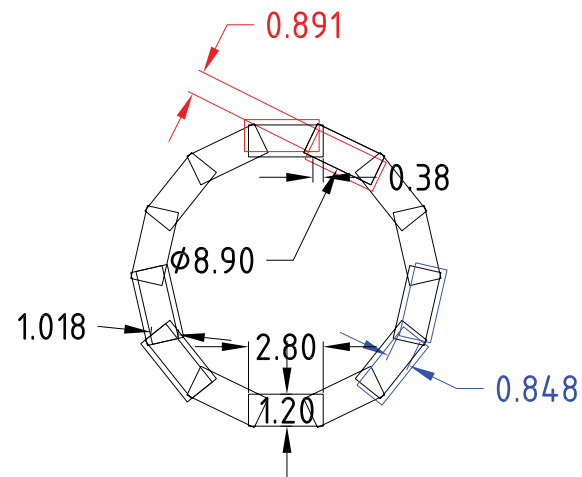

FOR PLANNING PURPOSES
NOT FOR CONSTRUCTION

No.	Revision Description	Drawn by	Date	Checked by	Date	Approved by	Date
A	Issued for planning	Jacob	19.05.2017	Henrich	23.05.2017	VdB	23.05.2017

NORTH YORKSHIRE POLYHALITE PROJECT - MINE SHAFT EARLY CONTRACTOR INVOLVEMENT CIVIL ENGINEERING			
Preliminary panel layout for the headgear chamber and for the MTS shaft			
Drawn by	Checked by	Approved by	Scale
Jacob	Henrich	VdB	1:100
Date 19.05.2017	Date 23.05.2017	Date 23.05.2017	Date
Project No: 40-AMC-WS-71-CH-DR-0080			REV: 0