

Appendix C

Method Statement - Operation of concrete batch plant

NORTH YORKSHIRE POLYHALITE PROJECT

Phase 4 – Concrete Batch Plant Operation and Maintenance RAMS

Document Number: 40-AMC-WS-72-SW-RA-0002

1. Contractor Document Submittal History:

Revision:	Date:	Prepared by:	Checked by:	Approved by:	Reason for Issue:
A	27/03/17	SW			Internal Review
0	15/05/17	HM	SF	JW	Issue to Sirius for Comment
0A	24/05/17	HM	SF	JW	Issue to Sirius for Comment
1	26/05/17				Issued for Use

2a. External Peer Review Required?

YES NO

Peer Review required: Purpose of submission For approval
 For information
 Other: _____

This document has been reviewed by the following individual for coordination, compliance, integration and acceptance and is acceptable for transmission to the above stakeholder for the above stated purpose.

Sign: _____ Role: _____ Name: _____ Date: _____

Sign: _____ Role: _____ Name: _____ Date: _____

2b. Review by External Peer (if required):

Reviewer Organisation	Job Title	Name	Signature	Date	Acceptance
					<input type="checkbox"/>

3. Acceptance by *Sirius Minerals*:

Sirius Minerals Review and Acceptance			
This is to be used for submitted documents requiring acceptance by <i>Sirius Minerals</i> .			
<input type="checkbox"/>	Code 1.	Accepted. Work May Proceed	
<input type="checkbox"/>	Code 2.	Not Accepted. Revise and resubmit. Work may proceed subject to incorporation of changes indicated	
<input type="checkbox"/>	Code 3.	Not Accepted. Revise and resubmit. Work may not proceed	
<input type="checkbox"/>	Code 4.	Received for information only. Receipt is confirmed	
Reviewed/Accepted by:(signature)	Print Name:	Position:	Date:
Acceptance by <i>Sirius Minerals</i> does not relieve the designer/supplier from full compliance with their contractual obligations and does not constitute <i>Sirius Minerals</i> approval of design, details, calculations, analyses, test methods or materials developed or selected by the designer/supplier.			

REVISION SHEET					
Report title	Phase 4 – Concrete Batch Plant Operation and Maintenance RAMS				
Document number	40-AMC-WS-72-SW-RA-0002				
Rev.	Revision description	Prepared by	Checked by	Approved by	Rev. Date
A	Internal Review – Edits to whole document	Hugh Medcalf	Steve Farrell		21/04/17
0	Issue to Sirius for Comment	Hugh Medcalf	Steve Farrell	Jonathan White	16/05/17
0A	Issue to Sirius based on review comments	Hugh Medcalf	Steve Farrell	Jonathan White	24/05/17
1	Issued for Use	Hugh Medcalf	Steve Farrell	Clive Dowdeswell	26/05/17



High Level RAMS (Risk Assessment Method Statement)

Doc. No.: 40-AMC-WS-72-SW-RA-0002	Rev: 1
-----------------------------------	--------

PART 1 – General Details			
Title of method statement:	Phase 4 – Concrete Batch Plant Operation and Maintenance		
Contract Name:	Early Contractor Involvement (ECI)	Contract Number:	RPA-127
Site Address & Telephone No:	AMC UK Site Office, Woodsmith Mine, Off B1416, Sneatonthorpe YO22 5HZ	Start Date:	July 2017
		Finish Date:	End of Project
		Duration:	TBD
		Working Hours:	24 hours per day / 7 days per week
Location of Works:	Sneatonthorpe		
Scope of Works / Work Activity:	Operation of the concrete batch plant.		

PART 2 – RAMS Sign Off, Consultation and Review					
	Signed	Print Name	Position/Status	Date	Notes
Prepared by		Siegfried Wenninger	Site Preparation and Planning	27/03/2017	To be completed by Person Preparing Method Statement or Sub-Contractor)
Employee consultation					Persons carrying out the work MUST be consulted and sign here
Tech review by		Jonathan White	Project Director	19/05/2017	To be completed by a Competent Person or Sub-Contractor)
H&S, Env. review by		Hugh Medcalf	Environment Advisor	19/05/2017	To be completed by a Competent Person
Authorised for construction (Contractor / Peer Review)		Jürgen Franz	Engineering Director	19/05/2017	To be completed by the Contractor or a peer of the person preparing the RAMS
Rejected by					To be completed by the Contractor or Competent Person

This document has been prepared for the Phase 4 planning submission. It presents a high level summary for the proposed operation of the concrete batching plant.

It should be noted that formal RAMS for plant operation (covering health and safety and environmental) will be prepared once the plant has been constructed and commissioned, and operational procedures have been identified.









PART 3 – Personnel and Resources

	Labour (Role/Trade and number of)	Qualification Required, to be shown at induction
Resources Required: (Including supervision)	1 x Construction Manager (D/S) 1 x Package Manager(D/S) 1 x Site Supervisor (D/S) 1 x Supervisor (D/S & N/S) 1 x Engineering/QAQC (D/S) 1 x HSE (D/S) (refer to Appendix B)	
Subcontractors	1 x Batch Plant Operator (D/S & N/S) 1 x Machine Operators (D/S & N/S) 4 x Mixer Truck Operator (D/S & N/S) 1 x Electrician (D/S Maintenance only) 1 x Mechanic (D/S Maintenance only) (refer to Appendix B)	Operator Certification Operator Certification Operator Certification & Drivers License Trade certificates Trade certificates
	How will they be supervised	AMC UK site supervision and management
Plant and Equipment:	Refer to the Plant Register in Appendix B.	
Materials:	Civil Works: n/a	Batch Plant Operation: Aggregates Sand Cement Water Admixtures

PART 4 – Key Operational Risks Identification

Key Operational Risks	Reference	Applicable to this activity Y/N
Site access, deliveries and removal of materials	Procedure	Y
Avoidance of buried underground services		N
Stability of structures		N
Demolition operations		N
Temporary works		N
Prevention of falls / work at height	Procedure	Y
Control of lifting operations	Procedure and Lift Plans	Y
Plant and machinery	Procedure	Y
Excavations		N
Confined spaces		N
Working near open water	Procedure	Y
Working with compressed air	Procedure	Y
Cutting/Grinding operations		N
Personal protective equipment	Procedure	Y
Working on electrical systems	Procedure	Y
Manual handling	Procedure	Y
Control of substances hazardous to health (COSHH)	COSHH Manual	Y
Noise	Procedure	Y
Vibration	Procedure	Y
Non-English speakers		Y
Environment risk assessment	Phase 4 Environmental Aspect and Impacts Assessment (EAIA)	Y
Site waste management	Site Waste Management Plan (SWMP)	Y
Site pollution or water contamination	Environmental Emergency Preparedness Plan (EPPP)	Y
Site – protected animals		N
Oil storage	Procedure	Y
Refuelling / Mobile Refuelling	Procedure	Y

PART 5 – COSHH

COSHH Assessment									
	Explosive	Oxidizing	Highly Flammable	Acutely Toxic	Corrosive	Hazardous to Environment / Aquatic Life	Skin/Eye Irritant	Long Term Health Hazard	Gas under Pressure
Applicable			Y			Y	Y	Y	Y



General Risk Assessment - – Concrete Batching Plant Operation

PART 6 – Risk Assessment

Activity / Task Individual elements of the task being carried out	Hazard Anything with the potential to cause harm. Include H&S, Environmental, Operational / Process and Design hazards	People Affected E=employee S=Sub-contractor V=visitor P=public O=other	Potential Outcome e.g. injury, damage etc.	Pre-Control Risk Assessment			Control Measures required Control measures must be effectively implemented if they are to work as intended Include the title and controls of the applicable Operating Procedures identified in Part P4	Post Control Risk Assessment Have risks been reduced as far as reasonably practical			Risk Ranking
				Likelihood 1 - 5	Severity 1 - 5	Risk Score 1 - 25		Likelihood 1 - 5	Severity 1 - 5	Risk Score 1 - 25	
Access to site (access and deliveries)	Live traffic	E/S/V/P	Road traffic accident causing injury	2	5	10	<ul style="list-style-type: none"> Access to site will be via the new Welfare Access, off B1416. Signage will be in place to forewarn vehicles of the site access junction. Deliveries are to be staggered to prevent large numbers of vehicles accessing site at the same time. 	1	5	5	Low
Deliveries of materials, aggregates and sand	Offloading and storage of materials	E/S	Injury due to materials being offloaded/stored incorrectly	2	4	8	<ul style="list-style-type: none"> Supervisor or delegate to control all deliveries. Aggregates and sand to be tipped into dedicated storage bins. Offloading to be undertaken using mobile equipment. Loose items to be palletized, where possible. Materials to be stacked securely. Stacking heights to be limited to 2 m where practical. 	1	4	4	Low

LIKELIHOOD	RATING	SEVERITY - HEALTH	SEVERITY - SAFETY
Almost Certain (>90%)	5	Multiple worker deaths e.g. Asbestos / Silica dust	Fatal accident to member of public or worker
Probable (50% - 90%)	4	Single worker death / life shortening health effect e.g. Lung disease	Major injury (RIDDOR) resulting in lost time. Irreversible disability
Possible (10% - 50%)	3	Irreversible health effects e.g. Loss of hearing, HAVS, Serious dermatitis	Injury resulting in over 7 days lost time
Remote (1% - 10%)	2	Reversible health effects e.g. Minor dermatitis, respiratory, treatment off site	Injury resulting in 1 to 7 days lost time
Unlikely (<1%)	1	Minor health effect for short period, no lost time e.g. skin irritation	Injury requiring First Aid but no lost time

		5	4	3	2	1	RISK RANKING	ACTION REQUIRED
Severity	5	5	10	15	20	25	High (12 – 25)	Do NOT start task; either engineer or design out the hazard, look at alternative methods
	4	4	8	12	16	20		
	3	3	6	9	12	15		
	2	2	4	6	8	10	Medium (7 – 11)	Do NOT start task; impose further control measures such as alternative methods or plant / materials
	1	1	2	3	4	5	Low (1 – 6)	No additional control measures required
		1	2	3	4	5		
		Likelihood						



General Risk Assessment - – Concrete Batching Plant Operation

PART 6 – Risk Assessment

Activity / Task Individual elements of the task being carried out	Hazard Anything with the potential to cause harm. Include H&S, Environmental, Operational / Process and Design hazards	People Affected E=employee S=Sub-contractor V=visitor P=public O=other	Potential Outcome e.g. injury, damage etc.	Pre-Control Risk Assessment			Control Measures required Control measures must be effectively implemented if they are to work as intended Include the title and controls of the applicable Operating Procedures identified in Part P4	Post Control Risk Assessment Have risks been reduced as far as reasonably practical			Risk Ranking
				Likelihood 1 - 5	Severity 1 - 5	Risk Score 1 - 25		Likelihood 1 - 5	Severity 1 - 5	Risk Score 1 - 25	
Use of mobile equipment (concrete trucks)	Mobile equipment	E/S	Severe injury or death	2	5	10	<ul style="list-style-type: none"> Designated haul routes to be established across site. Working areas to be demarcated (taped/barricaded/fenced) as necessary. All equipment to have reversing beepers. Operatives to maintain a safe distance from operated plant (e.g. outside of slew area of excavators). All equipment operators to hold training. Equipment to be operated in line with manufacturer's guidance (e.g. seat belts). All people on site to wear high-visibility PPE. 	1	5	5	Low

LIKELIHOOD	RATING	SEVERITY - HEALTH	SEVERITY - SAFETY
Almost Certain (>90%)	5	Multiple worker deaths e.g. Asbestos / Silica dust	Fatal accident to member of public or worker
Probable (50% - 90%)	4	Single worker death / life shortening health effect e.g. Lung disease	Major injury (RIDDOR) resulting in lost time. Irreversible disability
Possible (10% - 50%)	3	Irreversible health effects e.g. Loss of hearing, HAVS, Serious dermatitis	Injury resulting in over 7 days lost time
Remote (1% - 10%)	2	Reversible health effects e.g. Minor dermatitis, respiratory, treatment off site	Injury resulting in 1 to 7 days lost time
Unlikely (<1%)	1	Minor health effect for short period, no lost time e.g. skin irritation	Injury requiring First Aid but no lost time

		5	4	3	2	1	RISK RANKING	ACTION REQUIRED
Severity	5	5	10	15	20	25	High (12 – 25)	Do NOT start task; either engineer or design out the hazard, look at alternative methods
	4	4	8	12	16	20		
	3	3	6	9	12	15		
	2	2	4	6	8	10	Medium (7 – 11)	Do NOT start task; impose further control measures such as alternative methods or plant / materials
	1	1	2	3	4	5	Low (1 – 6)	No additional control measures required
		1	2	3	4	5		
		Likelihood						



General Risk Assessment - – Concrete Batching Plant Operation

PART 6 – Risk Assessment

Activity / Task Individual elements of the task being carried out	Hazard Anything with the potential to cause harm. Include H&S, Environmental, Operational / Process and Design hazards	People Affected E=employee S=Sub-contractor V=visitor P=public O=other	Potential Outcome e.g. injury, damage etc.	Pre-Control Risk Assessment			Control Measures required Control measures must be effectively implemented if they are to work as intended Include the title and controls of the applicable Operating Procedures identified in Part P4	Post Control Risk Assessment Have risks been reduced as far as reasonably practical			Risk Ranking
				Likelihood 1 - 5	Severity 1 - 5	Risk Score 1 - 25		Likelihood 1 - 5	Severity 1 - 5	Risk Score 1 - 25	
Cement transfer to silos	High pressure for tanker discharge	E/S	Severe injury or death	2	5	10	<ul style="list-style-type: none"> Follow relevant procedures for connecting to silo, transfer, release of residual pressure Adhere to maximum allowed pressure for discharge Adhere to maximum allowed flow for discharge Ensure appropriate equipment and high pressure hoses are used and free of damage Do not tamper with safety devices such as overpressure switches, emergency stop switches, etc. 	1	5	5	Low

LIKELIHOOD	RATING	SEVERITY - HEALTH	SEVERITY - SAFETY
Almost Certain (>90%)	5	Multiple worker deaths e.g. Asbestos / Silica dust	Fatal accident to member of public or worker
Probable (50% - 90%)	4	Single worker death / life shortening health effect e.g. Lung disease	Major injury (RIDDOR) resulting in lost time. Irreversible disability
Possible (10% - 50%)	3	Irreversible health effects e.g. Loss of hearing, HAVS, Serious dermatitis	Injury resulting in over 7 days lost time
Remote (1% - 10%)	2	Reversible health effects e.g. Minor dermatitis, respiratory, treatment off site	Injury resulting in 1 to 7 days lost time
Unlikely (<1%)	1	Minor health effect for short period, no lost time e.g. skin irritation	Injury requiring First Aid but no lost time

		5	4	3	2	1	RISK RANKING	ACTION REQUIRED
Severity	5	5	10	15	20	25	High (12 – 25)	Do NOT start task; either engineer or design out the hazard, look at alternative methods
	4	4	8	12	16	20		
	3	3	6	9	12	15		
	2	2	4	6	8	10	Medium (7 – 11)	Do NOT start task; impose further control measures such as alternative methods or plant / materials
	1	1	2	3	4	5	Low (1 – 6)	No additional control measures required
		1	2	3	4	5		
		Likelihood						



General Risk Assessment - – Concrete Batching Plant Operation

PART 6 – Risk Assessment

Activity / Task Individual elements of the task being carried out	Hazard Anything with the potential to cause harm. Include H&S, Environmental, Operational / Process and Design hazards	People Affected E=employee S=Sub-contractor V=visitor P=public O=other	Potential Outcome e.g. injury, damage etc.	Pre-Control Risk Assessment			Control Measures required Control measures must be effectively implemented if they are to work as intended Include the title and controls of the applicable Operating Procedures identified in Part P4	Post Control Risk Assessment Have risks been reduced as far as reasonably practical			Risk Ranking
				Likelihood 1 - 5	Severity 1 - 5	Risk Score 1 - 25		Likelihood 1 - 5	Severity 1 - 5	Risk Score 1 - 25	
Maintenance works	Slips, trips and falls	S/E	Injury	2	4	8	<ul style="list-style-type: none"> Operatives to be informed of the presence of maintenance activities. Excavations to be backfilled as soon as possible. Excavations to be taped/barricaded/fenced as necessary. Materials and other equipment not in use are to be stored appropriately and not congest the working area. Loading/unloading to be carried out on level ground, within designated areas. 	1	4	4	Low

LIKELIHOOD	RATING	SEVERITY - HEALTH	SEVERITY - SAFETY
Almost Certain (>90%)	5	Multiple worker deaths e.g. Asbestos / Silica dust	Fatal accident to member of public or worker
Probable (50% - 90%)	4	Single worker death / life shortening health effect e.g. Lung disease	Major injury (RIDDOR) resulting in lost time. Irreversible disability
Possible (10% - 50%)	3	Irreversible health effects e.g. Loss of hearing, HAVS, Serious dermatitis	Injury resulting in over 7 days lost time
Remote (1% - 10%)	2	Reversible health effects e.g. Minor dermatitis, respiratory, treatment off site	Injury resulting in 1 to 7 days lost time
Unlikely (<1%)	1	Minor health effect for short period, no lost time e.g. skin irritation	Injury requiring First Aid but no lost time

		5	4	3	2	1	RISK RANKING	ACTION REQUIRED
Severity	5	5	10	15	20	25	High (12 – 25)	Do NOT start task; either engineer or design out the hazard, look at alternative methods
	4	4	8	12	16	20		
	3	3	6	9	12	15		
	2	2	4	6	8	10	Medium (7 – 11)	Do NOT start task; impose further control measures such as alternative methods or plant / materials
	1	1	2	3	4	5	Low (1 – 6)	No additional control measures required
		1	2	3	4	5		
		Likelihood						



General Risk Assessment - – Concrete Batching Plant Operation

PART 6 – Risk Assessment

Activity / Task Individual elements of the task being carried out	Hazard Anything with the potential to cause harm. Include H&S, Environmental, Operational / Process and Design hazards	People Affected E=employee S=Sub-contractor V=visitor P=public O=other	Potential Outcome e.g. injury, damage etc.	Pre-Control Risk Assessment			Control Measures required Control measures must be effectively implemented if they are to work as intended Include the title and controls of the applicable Operating Procedures identified in Part P4	Post Control Risk Assessment Have risks been reduced as far as reasonably practical			Risk Ranking
				Likelihood 1 - 5	Severity 1 - 5	Risk Score 1 - 25		Likelihood 1 - 5	Severity 1 - 5	Risk Score 1 - 25	
Work at height	Falls from height	S/E	Fatal fall, falling objects	2	5	10	<ul style="list-style-type: none"> Work at height to be avoided if possible. Correct selection of plant for working at height (http://www.hse.gov.uk/work-at-height/wait/wait-tool.htm) Work at height equipment suitably inspected by a competent person at regular intervals Suitable fall protection to be provided where necessary e.g. safety harness All persons provided with suitable information, instruction, training and supervision. Edge protection to be provided where required. 	1	5	5	Low

LIKELIHOOD	RATING	SEVERITY - HEALTH	SEVERITY - SAFETY
Almost Certain (>90%)	5	Multiple worker deaths e.g. Asbestos / Silica dust	Fatal accident to member of public or worker
Probable (50% - 90%)	4	Single worker death / life shortening health effect e.g. Lung disease	Major injury (RIDDOR) resulting in lost time. Irreversible disability
Possible (10% - 50%)	3	Irreversible health effects e.g. Loss of hearing, HAVS, Serious dermatitis	Injury resulting in over 7 days lost time
Remote (1% - 10%)	2	Reversible health effects e.g. Minor dermatitis, respiratory, treatment off site	Injury resulting in 1 to 7 days lost time
Unlikely (<1%)	1	Minor health effect for short period, no lost time e.g. skin irritation	Injury requiring First Aid but no lost time

		5	4	3	2	1	RISK RANKING	ACTION REQUIRED
Severity	5	5	10	15	20	25	High (12 – 25)	Do NOT start task; either engineer or design out the hazard, look at alternative methods
	4	4	8	12	16	20		
	3	3	6	9	12	15		
	2	2	4	6	8	10	Medium (7 – 11)	Do NOT start task; impose further control measures such as alternative methods or plant / materials
	1	1	2	3	4	5	Low (1 – 6)	No additional control measures required
		1	2	3	4	5		
		Likelihood						



General Risk Assessment - – Concrete Batching Plant Operation

PART 6 – Risk Assessment

Activity / Task Individual elements of the task being carried out	Hazard Anything with the potential to cause harm. Include H&S, Environmental, Operational / Process and Design hazards	People Affected E=employee S=Sub-contractor V=visitor P=public O=other	Potential Outcome e.g. injury, damage etc.	Pre-Control Risk Assessment			Control Measures required Control measures must be effectively implemented if they are to work as intended Include the title and controls of the applicable Operating Procedures identified in Part P4	Post Control Risk Assessment Have risks been reduced as far as reasonably practical			Risk Ranking
				Likelihood 1 - 5	Severity 1 - 5	Risk Score 1 - 25		Likelihood 1 - 5	Severity 1 - 5	Risk Score 1 - 25	
Use of COSHH materials (concrete, cement, etc.)	COSHH materials	E/S	Injury	3	3	9	<ul style="list-style-type: none"> Use of COSHH materials to be avoided where possible. COSHH Assessments to be produced for all COSHH materials, including fuel, oil, cement, concrete. All COSHH materials to be stored in a lockable, banded COSHH store at the Woodsmith Mine when not in use. SDS (safety data sheets) to be held on site and readily accessible at all times during site works. Only trained and competent operatives to use COSHH materials, in line with COSHH Assessment. Suitable PPE to be provided in accordance with COSHH assessment findings. First-aid arrangements provided including trained personnel, first aid kit and eye wash station. Suitable health surveillance to be provided where necessary. 	2	3	6	Low

LIKELIHOOD	RATING	SEVERITY - HEALTH	SEVERITY - SAFETY
Almost Certain (>90%)	5	Multiple worker deaths e.g. Asbestos / Silica dust	Fatal accident to member of public or worker
Probable (50% - 90%)	4	Single worker death / life shortening health effect e.g. Lung disease	Major injury (RIDDOR) resulting in lost time. Irreversible disability
Possible (10% - 50%)	3	Irreversible health effects e.g. Loss of hearing, HAVS, Serious dermatitis	Injury resulting in over 7 days lost time
Remote (1% - 10%)	2	Reversible health effects e.g. Minor dermatitis, respiratory, treatment off site	Injury resulting in 1 to 7 days lost time
Unlikely (<1%)	1	Minor health effect for short period, no lost time e.g. skin irritation	Injury requiring First Aid but no lost time

		5	4	3	2	1	RISK RANKING	ACTION REQUIRED
Severity	5	5	10	15	20	25	High (12 – 25)	Do NOT start task; either engineer or design out the hazard, look at alternative methods
	4	4	8	12	16	20		
	3	3	6	9	12	15		
	2	2	4	6	8	10	Medium (7 – 11)	Do NOT start task; impose further control measures such as alternative methods or plant / materials
	1	1	2	3	4	5	Low (1 – 6)	No additional control measures required
		1	2	3	4	5		
		Likelihood						



General Risk Assessment - – Concrete Batching Plant Operation

PART 6 – Risk Assessment

Activity / Task Individual elements of the task being carried out	Hazard Anything with the potential to cause harm. Include H&S, Environmental, Operational / Process and Design hazards	People Affected E=employee S=Sub-contractor V=visitor P=public O=other	Potential Outcome e.g. injury, damage etc.	Pre-Control Risk Assessment			Control Measures required Control measures must be effectively implemented if they are to work as intended Include the title and controls of the applicable Operating Procedures identified in Part P4	Post Control Risk Assessment Have risks been reduced as far as reasonably practical			Risk Ranking
				Likelihood 1 - 5	Severity 1 - 5	Risk Score 1 - 25		Likelihood 1 - 5	Severity 1 - 5	Risk Score 1 - 25	
Lifting of heavy/bulky objects	Manual handling	E/S	Injury	3	3	9	<ul style="list-style-type: none"> Manual handling to be avoided where practicable (e.g. through mechanical lifting). For bulky objects which can be safely lifted by hand (e.g. wedge pit pumps etc.), use 2-person lifting. 	2	3	6	Low
Capture and treatment of surface water during major storm events	Contamination	E/S	Impacts outside the concrete batching plant facility	2	2	4	<ul style="list-style-type: none"> Design of surface water system to have capacity to contain >1 in 20 year storm event. Ensure pumps and treatment systems are installed and maintained to deal with storm events. 	1	2	2	Low
Specialist works	Various	E/S/V/P	Various	-	-	-	<ul style="list-style-type: none"> Risk assessments to be produced by appointed contractors for all specialist works. 	-	-	-	-

LIKELIHOOD	RATING	SEVERITY - HEALTH	SEVERITY - SAFETY
Almost Certain (>90%)	5	Multiple worker deaths e.g. Asbestos / Silica dust	Fatal accident to member of public or worker
Probable (50% - 90%)	4	Single worker death / life shortening health effect e.g. Lung disease	Major injury (RIDDOR) resulting in lost time. Irreversible disability
Possible (10% - 50%)	3	Irreversible health effects e.g. Loss of hearing, HAVS, Serious dermatitis	Injury resulting in over 7 days lost time
Remote (1% - 10%)	2	Reversible health effects e.g. Minor dermatitis, respiratory, treatment off site	Injury resulting in 1 to 7 days lost time
Unlikely (<1%)	1	Minor health effect for short period, no lost time e.g. skin irritation	Injury requiring First Aid but no lost time

		5	4	3	2	1	RISK RANKING	ACTION REQUIRED
Severity	5	5	10	15	20	25	High (12 – 25)	Do NOT start task; either engineer or design out the hazard, look at alternative methods
	4	4	8	12	16	20		
	3	3	6	9	12	15		
	2	2	4	6	8	10	Medium (7 – 11)	Do NOT start task; impose further control measures such as alternative methods or plant / materials
	1	1	2	3	4	5	Low (1 – 6)	No additional control measures required
		1	2	3	4	5		
		Likelihood						



General Method Statement – Concrete Batching Plant Operation

PART 7 – Contacts and Emergency

Emergency Contact Numbers		
	Name:	Contact Number:
Person Responsible For Works	Jonathan White	
Supervisor	TBD	TBD
Hospital	Scarborough General (A&E) Whitby Community Hospital (medical treatment only)	
First Aider	Sirius Medical Team	Nominated First Aiders
Location of First Aid Box	First Aid boxes will be available at the Site Offices, Concrete Batch Plant, and within all AMC UK vehicles.	
Process Impact Assessment Contacts	N/A	
Gas Emergency Call Out	National Grid	
Electricity Emergency Call Out	Northern Power Grid	
Water Emergency Call Out	Yorkshire Water	
Sewage Emergency Call Out	Yorkshire Water	
Emergency Procedures & Permits Required	AMC UK - Emergency Response Plan (ERP) AMC UK - Emergency Environmental Preparedness Plan (EPPP)	

PART 8 – Method Statement

Overview of Works

The operation of a temporary concrete batch plant, including:

- Delivery of sand, aggregate and cement to the concrete batch plant;
- Operation of the concrete batch plant – producing concrete; and
- Operation of the concrete batch plant – concrete recycling.

A site plan of the Concrete Batching Plant is presented in Appendix A.

Concrete Batch Plant Operation – Concrete Mixing/Production

The operational procedures for the Concrete Batching Plant will be defined in the 'Operations Manual' which will be provided once the plant has been constructed and commissioned.

The following is a general outline of the main sequences of works associated with the operation of the batch plant. Appendix B outlines the anticipated plant and labour to be used during its operation.

1. Sequence of Works for Sand and Aggregates Delivery

The delivery of sand and aggregates consists of the following sequence:

- Transport sand and aggregates to site in a sheeted or enclosed vehicle. Transport on public roads will follow the approved Traffic Management Plan.
- On arrival the delivery driver will be inducted and sign in to the site. The locations of aggregate storage bins and the volumes and type of aggregates to be delivered will be confirmed. The delivery driver will then drive the truck to the designated storage bins.
- At each delivery location an exclusion area will be set up for the duration of the delivery.
- The sand or aggregate will be unloaded into the designated storage bin.
- Overflow of the material out of the designated storage area will be picked up with the front end loader and dropped into the storage bund once the delivery has been completed.

2. Sequence of Works for Cement Delivery

The delivery of cement consists of the following sequence:

- The cement for the batching plant will be transported to site by road tanker or truck by a registered supplier; transport on public roads will follow the approved Traffic Management Plan.
- On arrival the delivery driver will be inducted and sign in to the site. They will meet with the Site Supervisor to confirm the locations of silos filling points and the volumes and type of products to be

delivered, the nature of construction works being undertaken and confirm understanding of the hazards (human health and environmental) and the control measures.

- The delivery driver will then drive the truck to the designated storage silo.
- At each delivery location an exclusion area will be set up for the duration of the delivery.
- The cement will be transferred to the silo in accordance with the delivery RAMS and cognisant of the information presented in the *Cementitious Material Storage and Handling* Pollution Prevention Guidance (appended to the EMP). The transfer of powdered materials from the tanker to the storage silos will be through a closed system of heavy duty hoses. The delivery of powder from road tankers generally relies on a compressor (blower) mounted on the tanker lorry. During the transfer of the cement powder to the silo, the tanker driver must maintain a constant flow of material into the silo without exceeding the flow capacity of the filter system or exerting excessive pressure in the silo (which is not a pressure vessel).
- The operator will keep a record of the start and finish times of deliveries and report this to the batching plant supervisor.

3. Sequence of Works for Concrete Production

The concrete batching process will be defined in the batch plant Operations Manual. In general it will consist of the following sequences:

- Transport of the sand and aggregates from the storage area to the feed hoppers;
- Filling of the aggregates and sand onto the weighting belt conveyor;
- Conveying the aggregates and sand into the skip;
- Emptying the skip into the double shaft mixer;
- Addition of cement, water and admixtures into the double shaft mixer;
- Mixing of the components for the concrete batch;
- Filling of the mixed concrete from the double shaft mixer into the concrete mixer trucks; and
- Distribution of the concrete to the required locations (Diaphragm Wall panels, shafts etc.).

4. Sequence of Works for Concrete Recycling

To prevent setting of the residual concrete in the truck mixer, truck mixers need to be cleaned during the operation and after the end of the working shift by injecting water while the drum is rotating. The concrete/water mixture created during this process will be recycled as follows:

- Dump residual concrete/water mixture into the loading hopper of the recycling plant
- The aggregates and sand content of the concrete gets washed out and is discharged into a mixed aggregate hopper for use in future concrete mixtures
- Process and mixing water is reclaimed for use in future concrete mixes and for cleaning mixer drums.

Dust and Silt Management

- Guidance information presented in the *Cementitious Material Storage and Handling Pollution Prevention Guidance* will be used to mitigate fugitive dust and sediment emissions (included in the Phase 4 *Environmental Management Plan* (EMP), refer to document number 40-AMC-WS-71- EN-PL-0004, Appendix E).

Noise Management

- Appendix D outlines the anticipated noise emission levels from the concrete batching plant. The control and monitoring of noise levels are outlined in the *Sirius Woodsmith Mine Noise and Vibration Management Plan*.

Surface Water Management

- Appendix E outlines the process for the capture, treatment and management of surface water within the concrete batching plant facility.

Equipment

In addition to the concrete batch plant, the following mobile plant will be used to undertake the concrete production works:

Front End Loader

- A front end loader will be used to deliver the bulk aggregate and sand to the feed hoppers of the batch plant.

Concrete Mixer Truck

- Concrete mixer trucks will be used to receive the ready mixed concrete and to distribute it on the worksite. During the travel and tentative waiting time, the mixer trucks will be used to agitate the concrete in order to avoid separation of the components (refer to Appendix C for general truck specifications).

Additional Operational Items

Housekeeping

- Refer to the *Housekeeping Pollution Prevention Guidance* contained in the Environmental Management Plan. See Appendix B of the Phase 4 Project Management Plan, document number 40-AMC-WS-71-PM-PL-0003.

Delivery and Storage of Materials

- Refer to the Phase 4 *Project Management Plan* document number 40-AMC-WS-71-PM-PL-0003, Section 10.4.5.

Abnormal Loads: Not applicable.

Re-fuelling (general)

- Fuel deliveries and re-fuelling of plant and equipment will be undertaken in accordance with AMC UK's pollution prevention guidance. The *Fuel Storage and Handling* Pollution Prevention Guidance is included in the Phase 4 *Environmental Management Plan* (EMP). Refer to document number 40-AMC-WS-71-EN-PL-0004, Appendix E.
- Re-fuelling of small plant and equipment will be undertaken with a spill-kit in place at all times during the re-fuelling operation.
- Should any spillages occur, AMC UK's *Environmental Emergency Preparedness Plan* (EEPP) contained in the Phase 4 *Environmental Management Plan* (EMP) will be followed. Refer to document number 40-AMC-WS-71-EN-PL-0004, Appendix C.

Permit to Excavate

Not applicable.

Compound Fencing

- Permanent or temporary (Heras) fencing will be provided by AMC UK around the concrete batching plant facility. Perimeter fencing for the wider Woodsmith Mine site will be installed and maintained by Sirius Minerals.

Wheel Wash

- The Woodsmith Mine site wheel wash will be used if equipment such as bulk delivery trucks use the public road for transport.
- Vehicles will use sealed internal haul roads where practicable.

Details of Welfare

The following welfare will be provided by AMC UK for this phase (set up during the previous phase of the project):

- 1 x Site office with kitchenette
- 1 x Canteen with kitchenette
- 1 x Toilet block, with washing facilities
- 1 x Drying room

Appendices:

Appendix A – Site Plan

Appendix B – Plant Register and Labour Loading

Appendix C – Typical Concrete Mixer Trucks

Appendix D – Concrete Batch Plant Noise Emission Forecast

Appendix E – Surface Water Management

Appendix A – Site Plan

Site Plan – Concrete Batching Plant

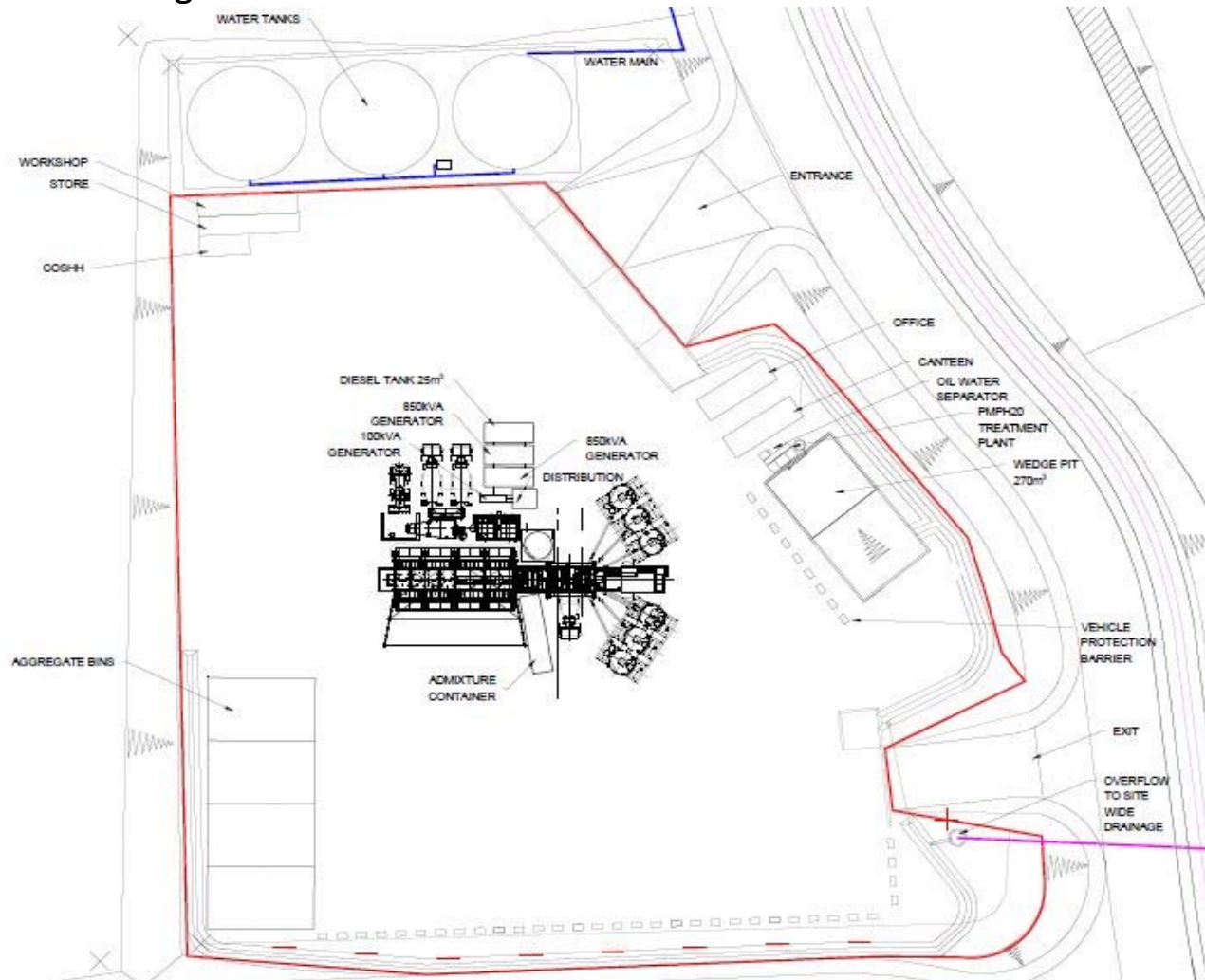

Appendix B – Plant Register and Labour Loading

Appendix B: Labour Loading

Phase 4 - Concrete Batch Plant Operation and Maintenance

AMC UK Labour Loading

Month	Site Management Dayshift 6 am - 6 pm 7 Days.	Site Management Nightshift 6 pm - 6 am 7 Days.	Site Operatives Dayshift 6 am - 6 pm 7 Days	Site Operatives Nightshift 6 pm - 6 am 7 Days	Total Dayshift 6 am - 6 pm 7 Days	Total Nightshift 6 pm - 6 am 7 Days	Total Number of Locals	Total Number of In-Migrants	TOTAL
All: July 2017 to end of Project	6	1	8	6	14	7	14	7	21

Appendix B: Plant Register

Sirius Minerals - Woodsmith Mine

Phase 4 - Concrete Batch Plant Operation & Maintenance

Plant	Numbers	Type	Sound power level LWA [db(A)]	Sound pressure level LpA [db(A)]	Power rating [kW]	% on-time	Start	Finish	24 hour working	Comments
Concrete Batch Plant	1 Unit	Liebherr Mobilmix 2.5	As per noise emission forecast, Appendix D	As per noise emission forecast, Appendix D	140	50	July 2017	End of Project	Yes	New
5m ³ Front End Loader	1	Cat 966M or similar	108		232	70	July 2017	End of Project	Yes	New / Less than 5 years old
6T Telehandler	1	Cat TL1255C or similar	104		106	90	July 2017	End of Project	Yes	New / Less than 5 years old
8m ³ Concrete Trucks	4	DAF CF 400MX-11 or similar	106		291	90	July 2017	End of Project	Yes	New / Less than 5 years old
1 MVA Batch Plant Generator	1	Frerk	103.3	85 @ 1m 80 @ 7m	800	90	July 2017	End of Project	Yes	New / Less than 5 years old
1 MVA Batch Plant Generator (backup)	1	Frerk	103.3	85 @ 1m 80 @ 7m	800	0	July 2017	End of Project	Yes	New / Less than 5 years old
100 kVA Batch Plant Process Generator	1	CPS		74 @ 1m 65 @ 7m	100	100	July 2017	End of Project	Night	New / Less than 5 years old

Appendix C – Typical Concrete Mixer Trucks

Appendix C: Typical concrete mixer trucks

The concrete truck maintains the material's liquid state through agitation, or turning of the drum, until delivery. The interior of the drum on a concrete mixing truck is fitted with a spiral blade. In one rotational direction, the concrete is pushed deeper into the drum. This is the direction the drum is rotated while the concrete is being transported to the building site. This is known as "charging" the mixer. When the drum rotates in the other direction, the Archimedes' screw-type arrangement "discharges", or forces the concrete out of the drum. From there it may go onto chutes to guide the viscous concrete directly to the job site.

6m³ Truckmixer

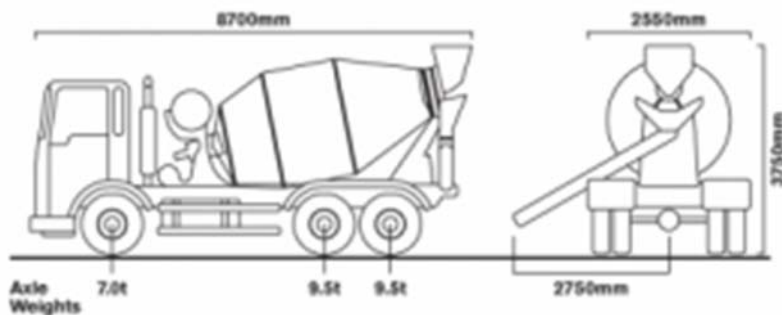

Length = 8.7m
Height = 3.75m
Width = 2.55m
Chute = 2.75m

A fully loaded 6m³ truck will weigh approximately 26 tonnes, depending on the type of concrete.

8m³ Truckmixer

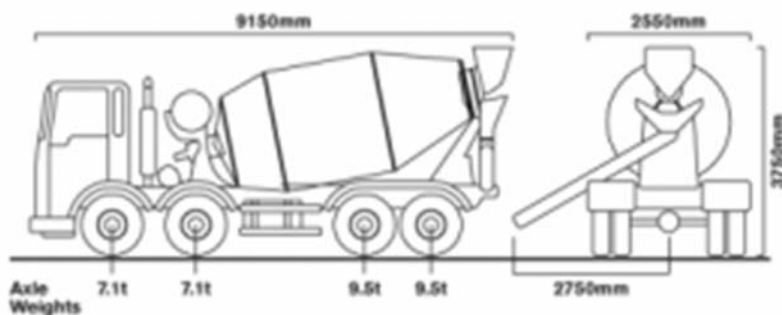

Length = 9.15m
Height = 3.75m
Width = 2.55m
Chute = 2.75m

A fully loaded 8m³ truck will weigh approximately 33 tonnes, depending on the type of concrete.

Appendix D – Concrete Batch Plant Noise Emission Forecast

LIEBHERR

Firm
AMC UK Joint Venture
c/o Deilmann-Haniel GmbH
Haustenbecke 1
44319 Dortmund
Germany

Liebherr-
Mischtechnik GmbH
Fahrmischer
Betonmischanlagen
Mischersysteme
Steuerungs- und Messsysteme
Betonrecycling

Unser Zeichen: **Br** Datum: **3.2.17** H. Berner
Prognose: **AMC_01.xlsm**
Anlagentyp: **Mobilmix 2,5 A-R/DW**
GA-/Projekt-Nr.: **036-50952**

Noise / Dust emission Forecast

NOISE EMISSION FORECAST

in accordance with ISO 9613-2

We have calculated below the potential noise immissions which are expected to occur in the influence area of the planned mixing plant. The individual emissions from the main noise generators have been taken into account. The evaluation level is determined as continuous sound level over the following reference period:

Reference period = 24 h during the day

Sound propagation and outside protection are calculated in accordance with standardization. The emission values used as a basis (sound power level) were measured at plants of similar construction. The following noise emitters principally influencing sound propagation have been taken into account:

Single-point noise sources: [Batching process](#)
[Weigher belt](#)
[Wheel loader](#)
[Gravel trucks when discharging load](#)
[Cement silo trucks during pneumatic transfer](#)
[Double shaft mixer](#)
[Truck mixers during loading process](#)
[Truck mixers during washing process](#)

Linear noise sources: [Wheel loader during transport](#)
[Gravel trucks during transport](#)
[Cement silo trucks during transport](#)
[Truck mixers during transport](#)

Liebherr-Mischtechnik GmbH
Im Elchgrund 12
88427 Bad Schussenried
Deutschland

Amtsgericht
Ulm/Donau HRB 640187
USt.-Id.Nr.: DE 8111 20069

Vorsitzender des Aufsichtsrats:
Uwe Rechtsteiner
Geschäftsführer
Dipl.-Ing. Ronald Drobek
Dipl.-Wirt.-Ing.(FH) Mark Figel
Dipl.-Wirt.-Ing.(FH) Michael Hörmann
Dipl.-Ing. Frank Siefert

Bankverbindungen:
Commerzbank AG, Filiale Biberach
1 330 000 (BLZ 654 400 87)
IBAN: DE33 6544 0087 0133 0000 00
BIC: COBA DE FF 654
Volksbank Biberach eG
53007 (BLZ 630 901 00)
IBAN: DE89 6309 0100 0000 0530 07
BIC: ULMVDE66

Single-point noise sources

In the immission forecast, stationary noise emitters are considered in idealised form as single-point noise sources:

Batching process:

The aggregates on the conveyor belt are thrown into the storage silo. Values are measured at a distance of 7 metres to the storage silos. Due to the all-round enclosure a noise protection level of 5 dB can be subtracted.

Weigher belt:

A bucket-type elevator is used to lift aggregates from the feed hopper to the storage silo and discharge them into it. Values were measured at a distance of 7 metres from the feed hopper. Due to the all-round enclosure a noise protection level of 5 dB can be subtracted.

Wheel loader:

Aggregates are transported from the storage compartment to the inline silos by wheel loaders. The measurements were taken from a distance of 7 m from the contour line of the wheel loader.

Gravel trucks when discharging load:

Washed aggregates delivered by trucks are discharged into storage containers or into the feed hopper. The influencing period is very short. Measurement of values was effected at a distance of 7 metres to the discharge point.

Cement silo trucks during pneumatic transfer:

Cement is supplied in silo trucks and blown into the cement silos by a compressor. In general, the vehicle engine is used to drive the compressor. Measurement of values was effected at a distance of 7 metres to the cement silo truck.

Double shaft mixer:

In the mixing plant, the mixer is considered the main noise emitter when mixing the aggregates, in particular when single gravel stones hit the outside wall of the mixer or become lodged and then scrape along between mixer arm and mixer wall. Measurement of values was effected at a distance of 7 metres to the mixer. Due to the all-round enclosure a noise protection level of 8 dB can be subtracted.

Truck mixers during loading process:

During the loading process the drum is rotating with nominal speed. The vehicle engine and the hydraulic system are the main noise emitters. Measurement of values was effected at a distance of 7 metres to the mixer.

Truck mixers during washing process:

To prevent setting of the residual concrete in the truck mixer, truck mixers need to be cleaned during the operation and after the end of the working shift by injecting water while the drum is rotating. Cleaning is effected at idle speed. Measurement of values was effected at a distance of 7 metres to the mixer.

Linear noise sources:

Mobile noise sources (traffic noise) are considered as linear noise sources.

Wheel loader during transport:

The wheel loader transports the aggregates from the storage dump to the charging hopper of the weigher belt. For this purpose wheel loaders must partly cross the plant premises and manoeuvring is required.

Gravel trucks during transport:

The truck transports the aggregates to the storage dump; for this purpose trucks must partly cross the plant premises and manoeuvring is required.

Cement silo trucks during transport:

Silo trucks deliver cement; for this purpose the trucks must partly cross the plant premises and manoeuvring is required.

Truck mixers during transport:

Truck mixers load concrete to transport it away from the plant; for this purpose the trucks must cross the plant premises of the plant and manoeuvring required.

Total evaluation level

The evaluation levels that were separately determined for each source of noise at the site of immission are energetically summed up. The total evaluation level is a value for average long-term noise immission at the site of immission for the relevant reference period.

Reference period = 24 h during the day

Immission point (IP)	Coordinates [m]			Total evaluation level $L_{r,total}$
	X	Y	Z	
IP 1	-50	0	4	71,5 dB(A)
IP 2	-100	0	4	61,3 dB(A)
IP 3	-200	0	4	53,8 dB(A)
IP 4	-300	0	4	49,7 dB(A)
IP 5	-800	0	4	39,3 dB(A)

Annex

Annex A: All data concerning the noise immission forecast are listed in Annex A. The table contains input values, interim calculation values and output data with reference to the single immission point.

Immission point: IP 1

Annex B: An overview over several immission sites with graduated colours in the noise immission map is shown in Annex B. From this map, noise propagation over a relevant area and possible local noise levels (evaluation levels) can be inferred.

DUST EMISSION FORECAST

Dust emission when filling cement silos

The cement silos are filled from the vehicles by means of an air compressor. The air enriched with cement dust is blown through the exhaust air filters on the cement silos. For the residual dust quantity at the filter outlet, see the guarantee for residual dust content.

Residual dust content < 10 mg/Nm³

Dust emission when filling the mixer

Aggregates with cement and water are mixed in the power mixer. During the time the mixer is filled with aggregates the air volume equivalent to the volume of the aggregates is displaced from mixer interior. This displaced air is drawn off via mixer exhaust filters with fan placed above mixer (see picture). Normally adding of aggregates is dust-free due to the moisture content of the aggregates stored.

Displaced air from the mixer interior when filling cement is led back into the upper part of the cement weighing hopper via an air equalizing hose (closed circle).

If in any case dust escapes from the closed system, most of the cement dust will be collected inside the plant lining. The quantity of cement dust emitted from the plant to the air is negligible.

The dust content of the mixer exhaust filter (pur gas side):

Residual dust content < 10 mg/Nm³

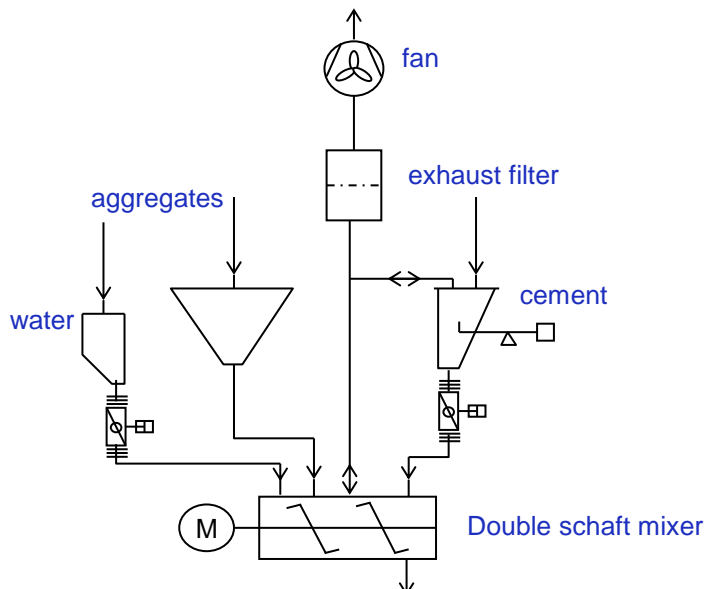

General Information

General description of the noise emission and the interpretation of it

The noise emission forecast estimates whether the mixing plant causes additional noise disturbances for local residents and how high they might be.

A comparison between the forecasted noise level and the corresponding emission points with limit values should serve as a basis for the permit.

Please note that the overall noise level depends greatly on the plant operators as well as on the overall plant operation.

Normen und Literatur

- [1] Sechste Allgemeine Verwaltungsvorschrift zum Bundes-Immissionsschutzgesetz (Technische Anleitung zum Schutz gegen Lärm – TA Lärm) Vom 26. August 1998 (GMBI Nr. 26/1998 S. 503)
- [2] Richtlinien für den Lärmschutz an Straßen (RLS-90) , Ausgabe 1990:02 & 2006:06
- [3] ISO 9613-2:1996 Acoustics — Attenuation of sound during propagation outdoors — Part 2
- [4] DIN 18005-1:1987-05 Noise abatement in town planning – Part 1: Fundamentals and directions for planning
- [5] DIN 18005-1 Beiblatt 1
- [6] Technischer Bericht zur Untersuchung der Geräuschemissionen von Baumaschinen, Umweltplanung, Arbeits- und Umweltschutz Heft 247, Hessische Landesanstalt für Umwelt, 1998
- [7] VDI 2714:1988-01 Schallausbreitung im Freien
- [8] Referenzmessungen, Liebherr Mischtechnik GmbH, Bad Schussenried
- [9] Technische Datenblätter der Firmen Infastaub, LWK, WAM, SALT

Yours sincerely,

LIEBHERR - MISCHTECHNIK GMBH

i.A.

Emission forecast data

Sound propagation in accordance with ISO 9613-2

Basic data	Plant type		Mobilmix 2,5 A-R/DW		Reference time for evaluation level		24 h		Concrete volume per day		2400 m³		Immission point											
	Works/project No.		036-50952		Operation in idle time		0 h		Proportion of aggregates by mass		2000 kg/m³		x [m]:											
	Date		03.02.2017		Supplement for idle times		0 dB		Proportion of cement by mass		300 kg/m³		y [m]:											
	File name		AMC_01.xlsm		Temperature		10 °C						z [m]:											
Person in charge		H. Berner		Relative humidity of air		70 %																		
Single-point noise sources	Proportion concrete	Total 0	Output 0	Individual amount	Cycle time	Number of cycles	Time of operation	Type	Sound power level L _W	Coordinates			sound reduction index R _W	Directivity index D _I	Solid angle coefficient K ₀	Shielding angle		Supplement			Evaluation level emission L _{r,Emission} *	Evaluation level immission L _{r,Immission}		
	%					-	h	-	dB(A)	x	y	z	dB(A)	dB(A)	dB(A)	Start	End	Idle	sound	impulse	dB(A)	dB(A)		
Batching process	100	2667 m³	150 kg/s				8,89	Stahl	103	-6	0	1	5	0	3			0,0	0	3	96,7	53,6		
Weigher belt	100	2667 m³	200 kg/s				6,67	Normal	108	-16	0	2	5	0	3			0,0	0	3	100,4	61,4		
Wheel loader	100	2667 m³		2 m³	15 s	1333	5,56	Laut	105	-20	0	3	0	0	3			0,0	0	6	104,6	67,0		
Gravel trucks when discharging load	100	2667 m³		22 t	30 s	218	1,82	Normal	105	-20	30	1	0	0	3			0,0	0	6	99,8	57,1		
Cement silo trucks during pneumatic transport	100	720 t	70 t/h	26 t		28	10,29	LKW	108	17	-6	1,5	0	0	3			0,0	0	0	104,3	56,5		
Double shaft mixer	100	2400 m³	110 m³/h				21,82	DW 2,5	108	0	0	5	8	0	3			0,0	0	3	102,6	59,8		
Truck mixers during loading process	100	2400 m³	110 m³/h	8 m³			21,82	Normal	103	0	-5	2	0	0	3			0,0	0	1,5	104,1	59,9		
Truck mixers during washing process	100	Interim washing period			2 min	300	10,30		100	10	25	1,5	0	0	3			0,0	0	1,5	97,8	50,4		
		Washing period after end of shift			6 min	3																		
Summe Punktschallquellen:																					111,2	69,8		
Linear noise sources (DIN 18005)	Coordinates of nodal points									Proportion of concrete	Number of journeys	Traffic volume vehic./h	Number of trucks	Speed 0 km/h	Up-hill gradients %	Road surface	Sound power level per meter L _{W'} dB(A)	Supplement			Evaluation level emission L _{r,Emission} *	Evaluation level immission L _{r,Immission}		
		1	2	3	4	5	6	7	8									9	%	vehic./h			%	km/h
Wheel loader during transport	x	-20,0	-10,0	-20,0							100	2667	111,1	100	20	10	1	86,6	0,0	0	0	101,7	60,4	
	y	30,0	10,0	10,0																				
	z	1,5	1,5	1,5																				
Gravel trucks during transport	x	25,0	-40,0	-40,0	25,0	25,0					100	436	18,2	100	20	10	1	78,7	0,0	0	0	102,7	65,3	
	y	30,0	30,0	-30,0	-30,0	30,0																		
	z	1,5	1,5	1,5	1,5	1,5																		
Cement silo trucks during transport	x	40,0	17,0	17,0							100	55	2,3	100	20	10	1	69,8	0,0	0	0	87,5	38,7	
	y	30,0	30,0	-6,0																				
	z	1,5	1,5	1,5																				
Truck mixers during transport	x	40,0	10,0	0,0							100	600	25,0	100	20	10	1	80,1	0,0	0	0	98,0	50,8	
	y	30,0	25,0	-5,0																				
	z	1,5	1,5	1,5																				
Summe Linienschallquellen																					106,1	66,6		
* L _{r,Emission} : reverence surface 1m²																					TotalEvaluation level emission L _{r,Emission}		112,3	
																					TotalEvaluation level immission L _{r,Immission}			71,5

Noise immission map

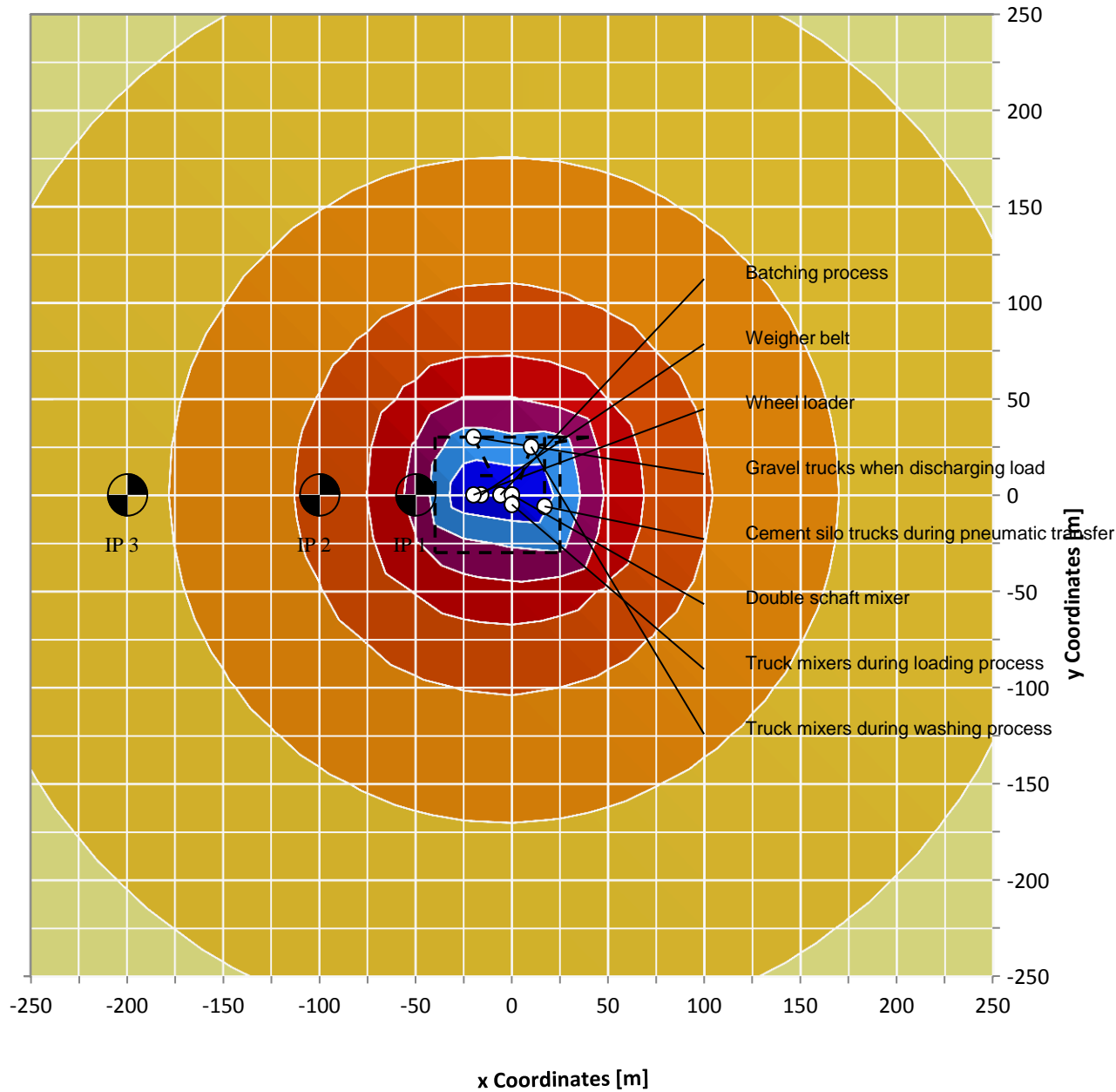

Informationen/Legende

Sound propagation in accordance with ISO 9613-2

rel. height above ground level: 4 m

TotalEvaluation level immission [dB(A)]

- 80-85
- 75-80
- 70-75
- 65-70
- 60-65
- 55-60
- 50-55
- 45-50
- 40-45
- 35-40
- 30-35

Plant type Mobilmix 2,5 A-R/DW
 Works/project No. 036-50952
 Date 03.02.2017
 File name AMC_01.xlsm
 Person in charge H. Berner

- Single-point noise sources
- - - Linear noise sources
- Obstacles
- Copse/development
- ←→ reflection

LIEBHERR
I^{PRO}
 version 1.2

Appendix E – Surface Water Management

This document outlines a summary of the proposed surface water management for the operational phase of the concrete batching plant facility at the Woodsmith Mine site.

The operation of the Concrete Batching Plant facility will include the capture and collection of surface water run-off from the facility. As part of the sustainable operation of this facility, AMC UK is looking to harvest rainwater for the production of concrete rather than obtaining potable water from the mains system.

To collect this rainwater, the Concrete Batching Plant has been designed with a sealed surface (concrete and grout impregnated bitumen) with a designed fall (1% fall) towards a proposed surface water 'wedge pit' (refer to Figure 1) and a network of perimeter ditches feeding into the wedge pit. The capacity of the wedge pit is 270 m³, which has been modelled to hold a 1 in 20 year flood event.

Surface water collecting in the wedge pit may be potentially impacted with fine suspended cementitious material from the facility operations and more coarse raw materials (such as sand and aggregates).

The treatment of the captured surface water under normal conditions (< 1 in 20 year storm event, with climate change considered) is as follows:

1. Settlement by gravity of coarse particulates within the wedge pit (elevated pH associated with the cementitious material may prevent the settlement of fine sediments requiring further treatment).
2. Pumping of surface water collected in the wedge pit to the 'Siltbuster PMPU20', using a permanent dedicated pump and floating strainer.
3. The 'Siltbuster PMPU20' has a three stage treatment, involving initial pH correction, removal of fine suspended solids precipitating out upon lowered pH and then a final pH adjustment (refer to Appendix A).
4. The 'Siltbuster' then decants to an oil/water separator removing potential floating hydrocarbons.
5. The treated surface water will then feed by dedicated pipework to the process water tanks for storage and re-use within the batching plant operation.

The estimated capacity of the Siltbuster PMPU 20 system is between 20 to 30 m³ per hour. The selected process equipment is constructed to allow maintenance and cleaning.

In the event of a significant storm event (> 1 in 20 year storm event), additional mitigation measures for the capture and management of surface water involves the direct pumping of excess water from the wedge pit into temporary storage in one of the process tanks via a dedicated pump and pipeline. Prior to the start of the pumping the selected tank will be isolated from the batching plant system

This temporary storage will be pumped back to the wedge pit for treatment following the storm event for subsequent treatment (the volumes of returned temporarily stored water will be dependent on weather conditions following the storm event).

With the overall capacity of the wedge pit, ditches and temporary storage tanks being approx. 370 m³, capture and treatment of 70% of a 1 in 100 year storm event (modelled to be 516 m³) can be contained and managed. Above this capacity the residual surface water will enter the wider site drainage system via the overflow point. It is considered that under these storm conditions the majority of surface water will be managed within this system (specifically the potentially more impacted first flush of the site), with the excess surface water being contained and managed in the wider site drainage system.

Appendices:

Figure 1: Batch Plant – Layout of the batch plant, generators, water tanks and other auxiliaries.

Appendix 1: Extract from Siltbuster “Solutions for the concrete industry”.

Appendix 2: Siltbuster Plans.

This drawing is the property of Sirius Minerals PLC. It is to be used for the purposes of the project only and is not to be used for any other purpose without the written consent of Sirius Minerals PLC. All rights reserved to the extent of the law. All other rights reserved.

This drawing is the property of Sirius Minerals PLC. It is to be used for the purposes of the project only and is not to be used for any other purpose without the written consent of Sirius Minerals PLC. All rights reserved to the extent of the law. All other rights reserved.

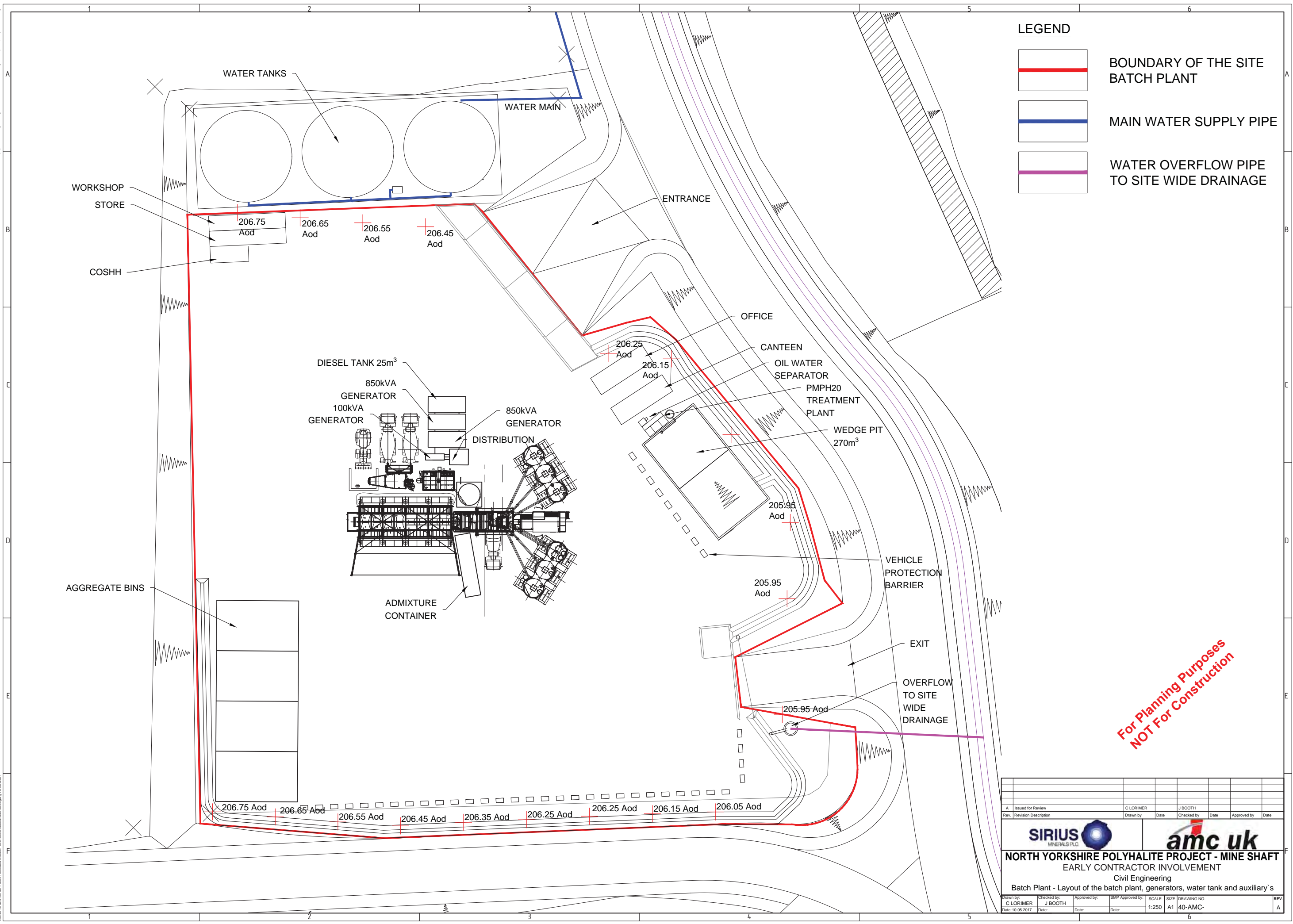

**For Planning Purposes
NOT For Construction**

A		Issued for Review	C LORIMER	J BOOTH		
Rev.	Revision Description	Drawn by	Date	Checked by	Date	Approved by
		SIRIUS MINERALS PLC		amc uk		
NORTH YORKSHIRE POLYHALITE PROJECT - MINE SHAFT						
EARLY CONTRACTOR INVOLVEMENT						
Civil Engineering						
Batch Plant - Layout of the batch plant, generators, water tank and auxiliary's						
Drawn by:	Checked by:	Approved by:	SMP Approved by:	SCALE	SIZE	DRAWING NO.
C LORIMER	J BOOTH			1:250	A1	40-AMC-
Date:	Date:	Date:	Date:			
10.05.2017						
						REV.
						A

Siltbuster®



Solutions for the Concrete Industry

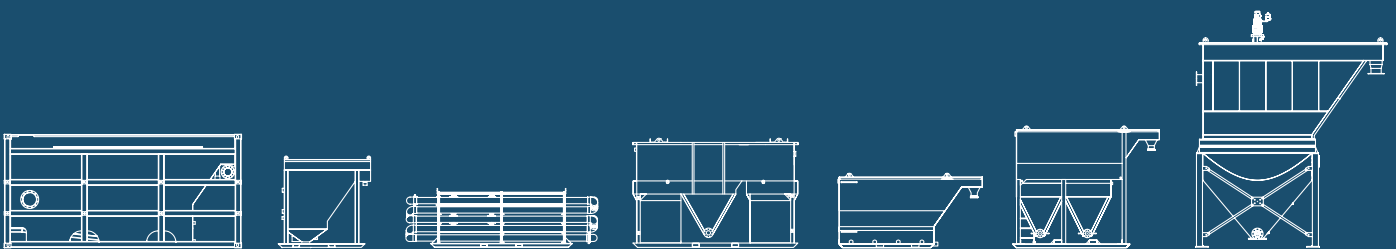

Hire, Sales & Technical Support

Registered Office: Siltbuster Ltd., Unipure House, Wonastow Road West, Monmouth NP25 5JA, Registered in England & Wales No.4737424



Who are Siltbuster?

At Siltbuster we pride ourselves as not being just a plant hire company but a solutions provider. Our reputation has grown over the past 10 years based on customer focused product development and ongoing technical support.

Water treatment isn't always as simple as it should be, that's why as part of our services we offer:

- Site visits to scope best solutions
- In-house laboratory testing of samples
- On-site commissioning and installation
- Telephone and on-site technical support
- Regional employees ensuring timely response to enquiries

We have the largest hire fleet of water treatment equipment in the UK operating both nationwide and internationally, enabling us to mobilise the equipment you need for when you need it.

Our equipment is used on projects ranging from small residential developments to some of the largest civil infrastructure schemes recently undertaken including: Heathrow T5, CrossRail, Hinkley Point C, the Forth Road Bridge, Copenhagen Metro and even the odd special project such as mud runs and the raising of the Costa Concordia!

But don't just take our word for it, pages 20 - 23 show a number of example case studies of recent projects we have been involved with in the concreting and hydrodemolition industries.

Why Treat Concrete Waste Water?

What is the problem?

Water that comes into contact with freshly exposed or poured concrete takes on an alkaline pH (circa 13) due to chemical reactions between the water and free lime particles within the cement.

While everyone is familiar with the dangers associated with acids, highly alkaline substances such as concrete wash water can be just as corrosive and if left unchecked/untreated can cause concrete burns, damage to vegetation and the surrounding ecosystem and ultimately result in the death of aquatic life. If it was bottled, it would require warning labels including:



Water with a high pH can look "clean", however once the solids have been removed, it still remains highly alkaline, hence the term "Silent Polluter".

Did you know...

To dilute just one IBC of concrete wash water (pH 12) you would need **four Olympic swimming pools** of water to bring it back to neutral (pH 7)! That is over 10,000 m³ of water

pH Scale



Common Sources of Alkaline Waters on Construction Sites:

- Washing down of machinery used with fresh concrete, e.g. concrete chutes, drums & pumps
- Cutting or coring of concrete structures
- Hydrodemolition (high pressure water cutting)
- Surface water run-off from recently lime stabilised sites
- Stockpiled or spread crushed demolition materials
- Placement of fresh concrete beneath groundwater e.g. piled foundations
- Placement of fresh concrete in a water course e.g. Bridge abutments

A common misconception when dealing with pH waste water is that it can be easily resolved by dilution. However, the pH scale is logarithmic therefore one unit change on the scale is a tenfold increase in strength.

Dilution to Reduce pH	
pH 11.7	1:1
pH 10	10:1
pH 9	100:1
pH 8	1,000:1
pH 7	10,000:1

Why Should We Care About pH?

Environmental

Due to the minimal effect of dilution even small volumes of concrete wash water have the potential to have a significant impact when discharged into the environment potentially causing:

- Destruction of vegetation and ecosystems
- Death of aquatic life either by sudden pH changes "shocks" or extremes pH levels
- Damage outer surfaces of aquatic life like gills, eyes and skin
- Inability to dispose of metabolic waste
- Increases the toxicity of other substances



Legislative

Guidance published by the Environment Agency in their Regulatory Position Statement "Managing Concrete Wash Waters on Construction Sites" sets out the legal requirements to treat solids laden, high pH water on construction sites. Summarised in the table below:

Volume	Discharge to Ground	Discharge to Surface Water
Small Discharges (up to 10 loads / Week)	Untreated or Treated	Fully Treated (pH & Solids)
Medium Discharges (up to 50 loads / Week)	At Least Solids Removal	Fully Treated (pH & Solids)
Large Discharges (51 - 100 loads / Week)	Fully Treated (pH & Solids)	Fully Treated (pH & Solids)
Very Large Discharges (>100 loads / Week)	Environmental Permit Needed Full Treatment will be Required	

All subject to conditions specified in the RPS.

Financial

The financial implications of causing a pollution incident can be crippling for an organisation. It is now common for companies to be asked to declare historical environmental incidents when tendering for work. Therefore previous mistakes can hinder winning new projects!

Additionally since the publication of the Sentencing Guidelines in 2014 by the Sentencing Council, firms convicted of knowingly causing a pollution incident could face fines of upto £3m!

At what pH can wash water typically be discharged?

Typical discharge consents for controlled waters ie. surface water courses and groundwater, requires a pH between 6 & 9 (subject to Environmental Permit Limits where relevant).

Whereas, discharging to sewer a typically requires a pH between 5 & 10 (subject to agreement with the water authority, typically in the form of a Trade Effluent Consent).

Alternatively high pH water can be tankered off-site however this is an expensive option at circa £140/m³.



Purpose designed and built pH Controller by Siltbuster for accurate control, recording and neutralising of high pH water

pH Adjustment Methods

How can the pH be adjusted?

Alkaline water traditionally neutralised by adding controlled amounts of an acid to reduce the pH.

The most commonly used reagents to neutralise alkaline waters are:

- Mineral Acid (either sulphuric or hydrochloric acid)
- Citric acid
- Carbon dioxide
- Self buffering solutions

Comparison of pH adjustment methods:

Mineral & Citric Acid

- Very hard to control (see steep titration curves below - no effect then sudden change)
- Careful chemical handling methods are needed
- If used in powdered form dose rates are easily misjudged due to time taken to fully dissolve

Carbon Dioxide

- High level of control - as it forms a very weak acid
- Slower reaction rates suited to automatic pH adjustment systems

Self buffering solutions

- Needs monitoring to ensure it is replaced once depleted

The benefits of Carbon Dioxide for pH adjustment:

Siltbuster treatment systems utilise CO₂ as an innovative way of treating high pH wash water, providing significant advantages over traditional methods, including:

- Carbon Dioxide is **virtually impossible to acidify the water though overdosing**
- Carbon Dioxide is more cost effective than any other solution, including mineral acid or citric acid (**£0.30 per m³ v's over £2.40 per m³**)
- Neutralisation can be accurately controlled due to the **near linear rate of neutralisation**
- Carbon Dioxide **does not elevate BOD, Chlorides, Sulphates, etc.**, which would otherwise be secondary pollutants
- **Easy and safe to store** - no specialist training or PPE
- Carbon Dioxide **does not leave the site with an IBC of liquid waste or containers requiring disposal**

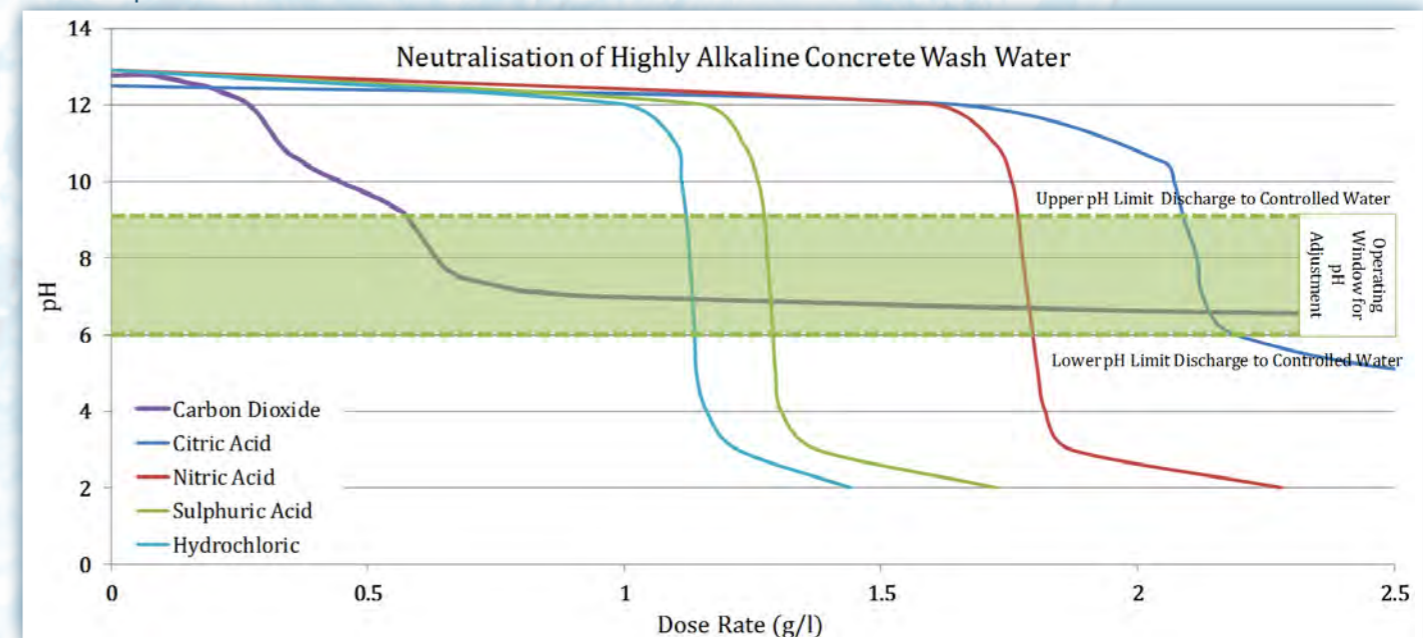

PMPU

Integrated pH Adjustment & Suspended Solids Removal



The Unit

Siltbuster's PMPU10 and PMPU20 units offer integrated pH adjustment and fine solids separation for flow rates of up to 30 m³/hr.

Ideal for treating high pH cementitious wash water from concrete batching plants, tunnelling works and precast concrete factories. However the system is equally as effective within a construction environment.

Utilising an integrated 3 Stage treatment process, the unit maximises pH adjustment, solids precipitation and removal within the footprint of a single skid.

Automatic Carbon Dioxide dosing ensures optimum pH levels are maintained.

How it Works

The Siltbuster PMPU Unit provides three stages of treatment within a single integrated unit. These stages are:

- Stage 1: Initial pH adjustment to achieve a pH of circa 10.5 to maximise the precipitation of solids
- Stage 2: Recovery of suspended solids within a clarification stage. The settled solids collect within a hopper and can be removed by opening the gate valve and can be pumped into a skip or sludge storage tank for dewatering or off-site disposal
- Stage 3: Final stage pH adjustment to achieve a user set pH. The clean pH adjusted sediment free water will then be discharged from the outlet weir of the unit

Did you know...

Typical discharge consents for controlled waters (surface water/groundwater) require a pH between 6 and 9. Whereas discharging to sewer a pH between 5 and 10 is typically permitted.



KEY ADVANTAGES

- + Digital pH controller means minimal labour required
- + Readily transportable, fast and simple to deploy, easy to operate
- + Optional data logger to record discharge compliance

TYPICAL APPLICATIONS

- + Avoids the health and safety risks associated with handling acid
- + Digital controller eliminates the risk of under / over adjusting the pH
- + Does not increase the Chloride, Sulphate or COD (Chemical Oxygen Demand)

- 1 INTEGRATED CO₂ SPARGER
- 2 MIXERS KEEP SOLIDS SUSPENDED
- 3 INTEGRATED LAMELLA CLARIFIER
- 4 SECOND STAGE pH ADJUSTMENT
- 5 SLUDGE STORAGE HOPPER & PUMP
- 6 TYPICALLY USED WITH BULK CO₂

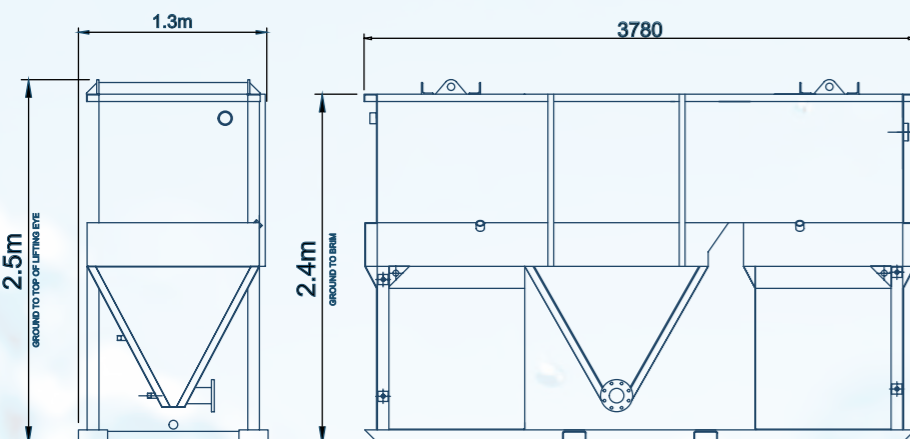

PMPU Data Sheet		
	PMPU10	PMPU20
Length:	3.2 m	3.8 m
Width:	1 m	1.3 m
Height:	2.2 m	2.7 m
Empty Weight:	1,200 Kg	2,500 Kg
Capacity:	0-15 m ³ /hr	0-30 m ³ /hr
Inlet Size:	4" F Bauer	
Outlet Size:	4" M Bauer	
Power Req.	415V 32A	

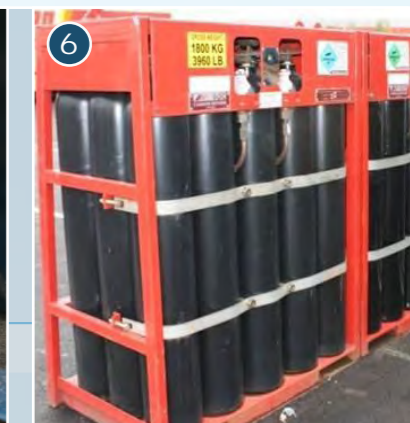

For Hire, Sales & Technical Support call Siltbuster® on

Siltbuster®

MODEL REF:

FB50

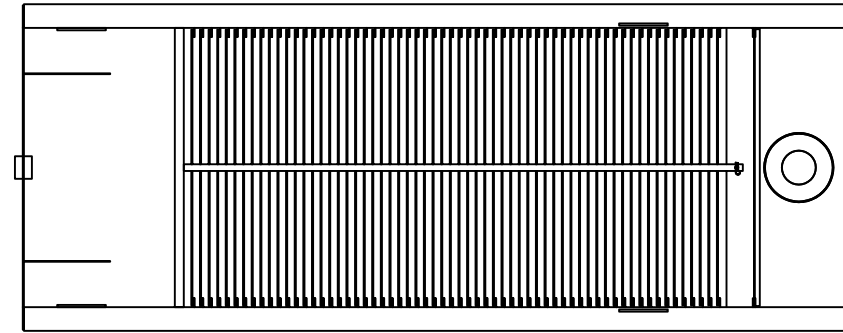

PLAN

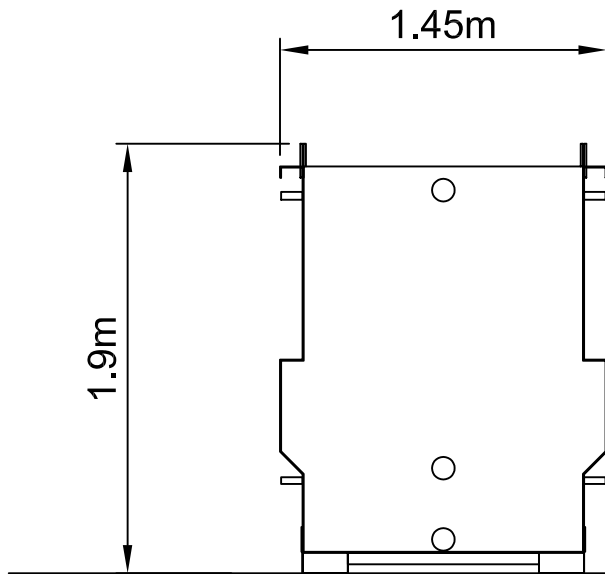

FRONT ELEVATION

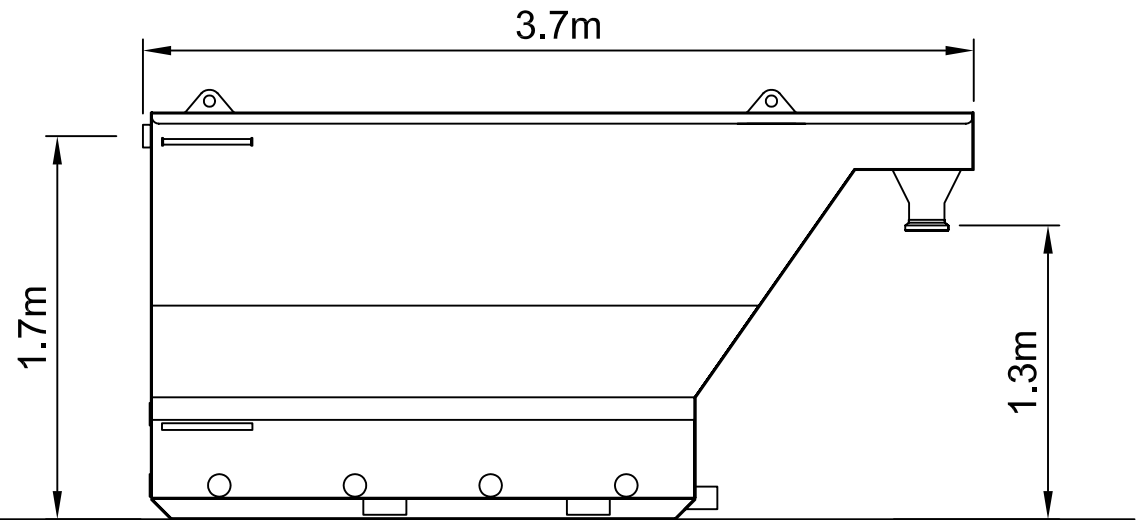

SIDE ELEVATION

Siltbuster is a registered trademark of Siltbuster Ltd.
Dimensions are indicative and due to ongoing product development are subject to change without notice.
This drawing and design are the copyright of Siltbuster Ltd and shall not be reproduced or used without written permission.

Project	Title	
SILTBUSTER FB50	TYPICAL DETAILS	SILTBUSTER LTD, UNIFIRE HOUSE, WONASTOW ROAD, WEST MONMOUTH MONMOUTHSHIRE NP25 5JA



PMPU20

SKID MOUNTED

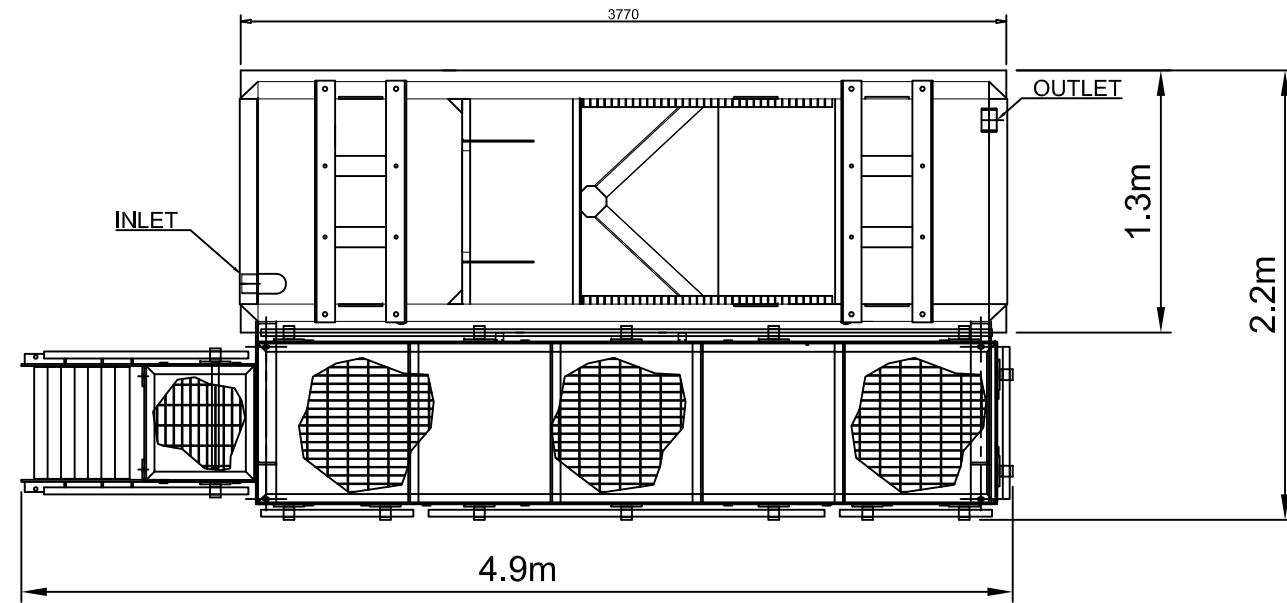

PLAN ELEVATION

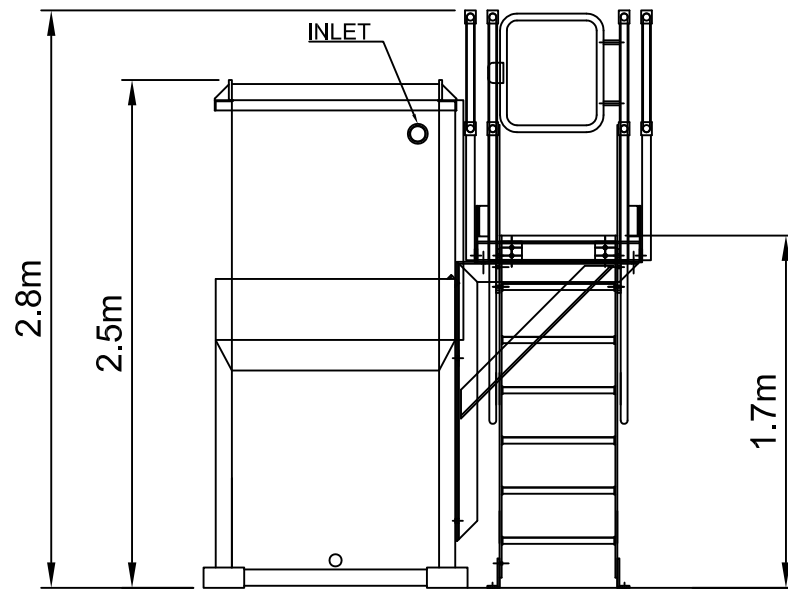

END ELEVATION

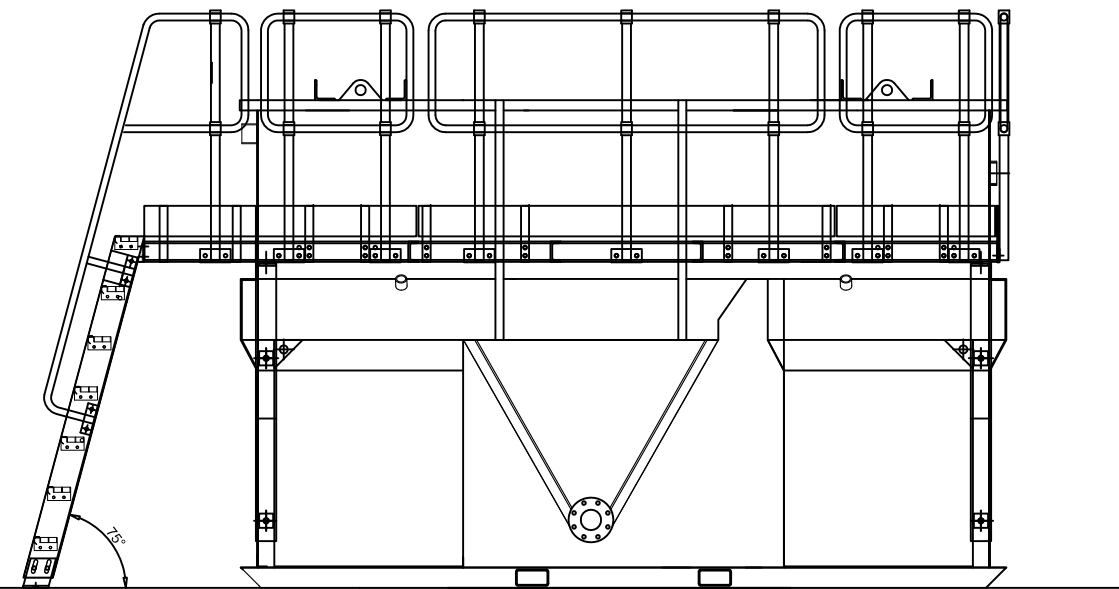

SIDE ELEVATION

Siltbuster is a registered trademark of Siltbuster Ltd.
Dimensions are indicative and due to ongoing product development are subject to change without notice.
This drawing and design are the copyright of Siltbuster Ltd and shall not be reproduced or used without written permission.

Project
PMPU20 WITH WALKWAY

Title
TYPICAL DETAILS

Siltbuster
SILTBUSTER LTD,
UNIPURE HOUSE,
WONASTOW ROAD, WEST
MONMOUTH
MONMOUTHSHIRE
NP25 5JA