

Amendments/Additional Information

- Amended layout of buildings/outside areas
- Additional background information
- Amended design
- Revised access arrangements
- Change of description of proposed development
- Change in site boundaries
- Other (as specified below)

.....
.....
.....
.....
.....

Jill Bastow

From: Alan Tomlinson
Sent: 21 July 2017 10:54
To: Jill Bastow
Subject: RE: Planning conditions - Lingers Hill
Attachments: J01 - Joinery Section.pdf; J02 - Joinery Plan Section.pdf

AMENDED

Notes

Dear Jill,

Thank you for your email and acceptance of the proposed 'small window' detail – I will instruct the joinery workshop as suggested.

Regarding the large window(s) on the garden elevation. On the basis that the Oak stud (mullion) will be added into our frame design, are you happy for the single casements to either side of it to use our standard casement profiles (as per section drawings attached)?

Best Regards

Alan

--

Alan Tomlinson
Oakwrights Country Buildings & GreenRooms

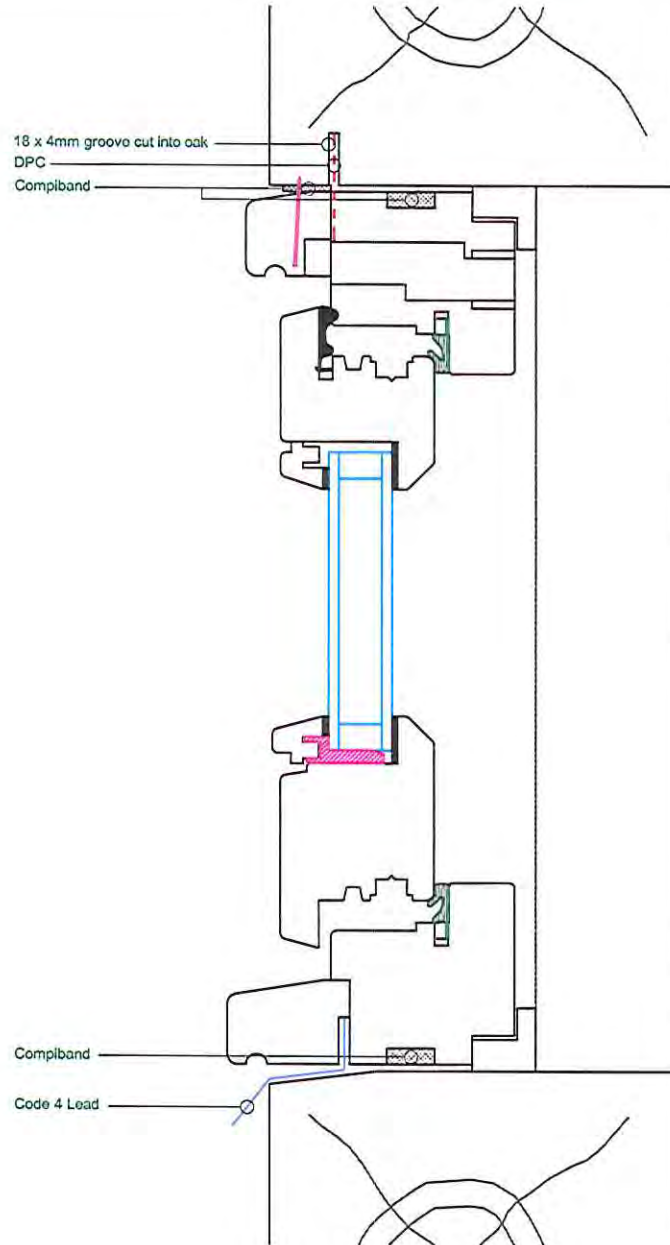

Generic detail only - Please refer to contract appendices for details of Oakwrights Design/Supply/Fit responsibilities for the components shown in this drawing.

© This drawing, its contents, and all information contained therein is protected by copyright. It may be used only for its intended purpose under a contract with J. Crane Sawmills Ltd, but specifically not for any other use or purpose.

AMENDMENTS

Notes

Please note that whilst this drawing has been prepared using the best available information with regards to timber sizes and general dimensions, as the design has not been subjected to scrutiny and all specific information is the responsibility of the structural engineer, the checking process, leading to the production of the necessary structural calculations for submission to the local authority building control department will happen once the design has been agreed and signed off. It is not impossible that as a result of the scrutiny some minor changes may be required. Dimensions & standards supplied are minimum requirements to meet current Building Regulations and are subject to change dependent on criteria for each project. Do not scale from this drawing. All dimensions are to be checked on site.

Generic Standard Details

OCB Details

Drawing No: OCB/GSD/301	Drawn by: JY
Scale: NTS	Date: 26/08/2015

Joinery Section



The Lakes, Swainshill, Hereford, HR4 7PU

www.countrybuildings.co.uk

© This drawing, its contents, and all information contained therein is protected by copyright. It may be used only for its intended purpose under a contract with J.J. Crump Drawings Ltd. but specifically not for any other use or purpose.

AMEND

Notes

Please note that whilst this drawing has been prepared using the best available information with regards to timber sizes and general construction details, at this stage it has not been subjected to the scrutiny and verification of an independent structural engineer. This checking process, leading to the production of the necessary structural calculations for submission to the local authority building control department will happen once the design has been agreed and signed off. It is not impossible that as a result of this scrutiny some minor changes may be required. Dimensions & standards supplied are minimum requirements to meet current Building Regulations and are subject to change dependent on criteria for each project. Do not scale from this drawing. All dimensions are to be checked on site.

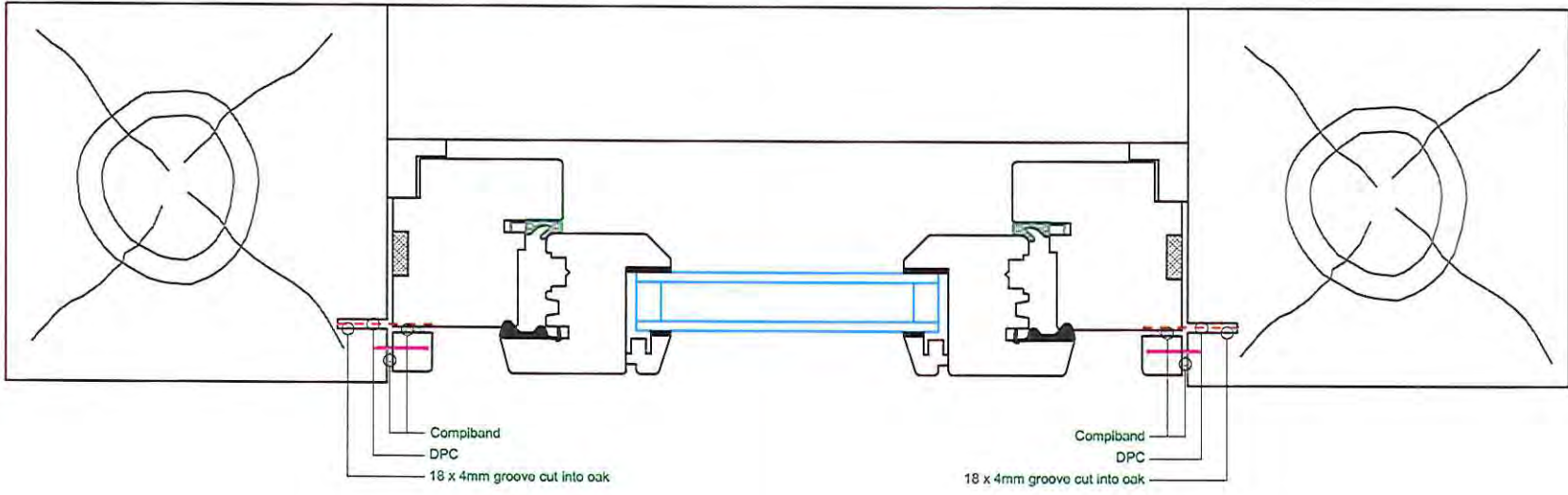

Generic Standard Details

OCB Details

Drawing No: OCB/GSD/302	Drawn by: JY
Scale: NTS	Date: 26/08/2015

Joinery Plan Section



The Lakes, Swainshill, Hereford, HR4 7PU

www.countrybuildings.co.uk

Generic detail only - Please refer to contract appendices for details of Oakwrights Design/Supply/Fit responsibilities for the components shown in this drawing.

Jill Bastow

From: Alan Tomlinson
Sent: 13 July 2017 15:14
To: Jill Bastow
Cc: OCB Projects
Subject: RE: Planning conditions - Lingers Hill
Attachments: OW02-Window_Details-A3.pdf

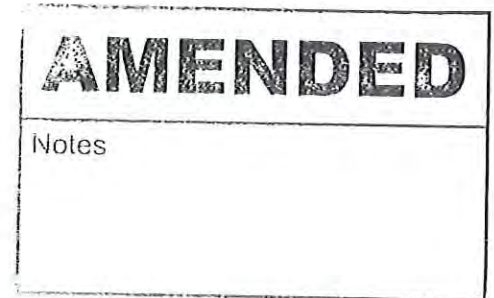

Dear Jill,

Our joinery suppliers are concerned about the manufacture of such a relatively large flush fitting window.

I have asked our clients if they are happy for us to introduce an additional stud (or mullion as you refer to it) into the green oak frame such that that single casements can be fitted either side of it – I believe this was your preference.

The small window has been manufactured as per the attached drawing (i.e. without a horizontal glazing bar). I have asked our clients for a close-up photograph of one of the existing windows on the roadside elevation, and the paint/colour specs so that we can better understand what is entailed in trying to match it.

Best Regards

Alan

--

Alan Tomlinson
Oakwrights Country Buildings & GreenRooms

JTB

Dawn Paton

From: Jill Bastow
Sent: 07 July 2017 11:44
To: Planning
Subject: FW: Planning conditions - Lingers Hill
Attachments: Window_Details RevA-signed.pdf; Limb - Gable Windows.pdf; Limb - Bi-fold.pdf; Double Doors-Open In LH.PDF; Double Doors-Open Out LH.PDF; Sovereign SX70 - Light Oak sample photo.jpg; SX70_Woodstairs_TDS_15_V4.pdf

AMENDED
Notes

From: Alan Tomlinson
Sent: 05 July 2017 12:41
To: Jill Bastow
Cc:
Subject: FW: Planning conditions - Lingers Hill

Dear Jill,
Apologies for the delay returning to you.
Attached are the constructional details of the proposed joinery items to the extension.
Also attached is a photograph of a sample length of air dried Oak coated with 'Sovereign SX70 – Light Oak' (N.B. The top face is coated, the front face with the writing is not) and the relevant spec sheet for the product.
Best Regards
Alan

--
Alan Tomlinson
Oakwrights Country Buildings & GreenRooms

NYMNPA
 -7 JUL 2017
 Kw

Limb Sample

Sovereign SX70

NYMAN
-7 JUL 2017



Data Sheet No:
TDS 15
Version 4

AMENDED

SOVEREIGN ^{Notes} TECHNICAL INFORMATION SHEET SX70 WOODSTAINS

Description

Sovereign SX70 Woodstain is a high quality solvent based woodstain, containing a flexible alkyd resin along with water repellents, pigments, flow additives, UV absorbers and a broad-spectrum fungicide.

Sovereign SX70 Woodstains are compatible with the SX70 range of Basecoats and Topcoat.

Form Supplied: Liquid, ready to use

Pack Sizes: 1litre and 5 litres

Colour Range: Teak, Red Cedar, Walnut, Black, Mahogany, Pine, White, Spruce, Antique Pine, Mid Oak, Light Oak

Contains: Long oil alkyd resin and speciality additives

Properties

Suitable for all types of soft and hardwood to give a decorative wood finish which is tough, durable, flexible and water resistant in all types of situations, e.g. on doors, windows, skirtings, dado rails, panelling, soffits, barge boards, etc.

Usage/Preparation

Surfaces must be sound, clean and dry before coating. Timber must have a moisture content of less than 18%. Existing paint coating must be fully removed back to clean, bare timber. Previously stained timber should have any loose flaky material removed and then the surfaces lightly sanded in the direction of the grain. Moss, mould and algae should be treated with Sovereign Dentolite, the growths removed and the timber allowed to dry. Clean all surfaces of timber with methylated spirit. Some timbers contain extractives that can bleed through coatings; a trial application is recommended.

Resinous deposits should be scraped off and cleaned with methylated spirits. Do not use knotting solutions, allow knots to "bleed out" through the coating and remove resin with a scraper when necessary. Non-durable external timber should be treated with Sovereign Timber Preservative.

Stir well before use. Do not use straight from the container, decant a small amount into a suitable receptacle, do not put back part used material into the can.

SX 70 is designed to be applied to bare timber or existing wood stains. A minimum of two coats must be applied. Apply using a high quality wood stain brush, working in the direction of the grain using the minimum number of brush strokes. On new work the first coat should be applied to all sides prior to assembly. End grains should be sealed and the backs of beads and rebates coated and special attention should be given to the tops and bottoms of doors and the underside of sills. Metal fixing must be suitable for external use i.e. stainless steel or galvanised. Nails holes should be filled with Sovereign Wood Filler. Apply the second coat as soon as the first has thoroughly dried, around 24 hours in good conditions. Third and subsequent coats can be applied if a deeper colour or greater protection is required.

Do not apply in temperatures below 10°C in damp conditions or when rain is imminent.

TECHNICAL DATA SHEET

MINPA
-7 JUL 2017

Do not scale from this drawing.

The drawing was prepared by AJB Group Ltd. The copyright in the design and drawing belongs to AJB Group Ltd. Duplication of this drawing and the design cannot be made without prior written consent from AJB Group Ltd.

© 2013 AJB Group Ltd

AMENDED

Notes

A

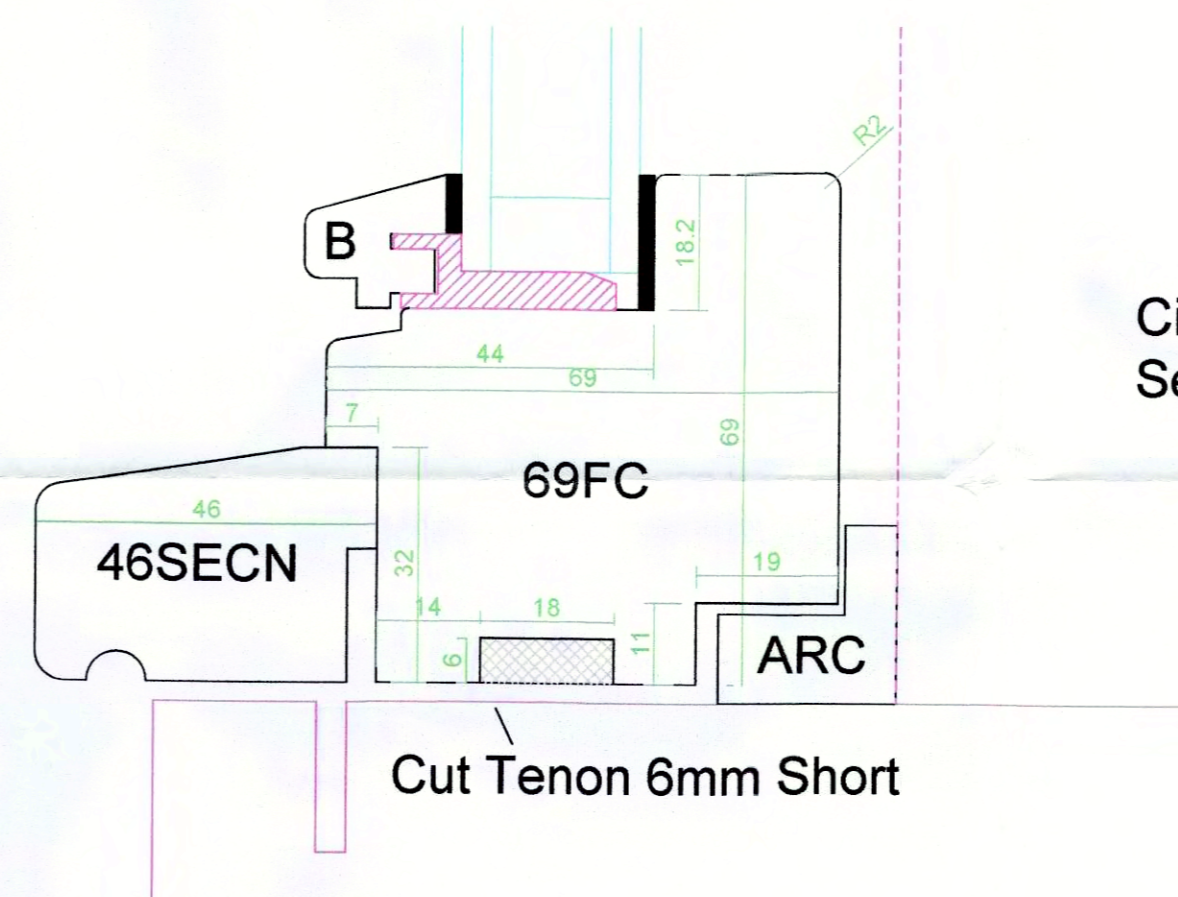
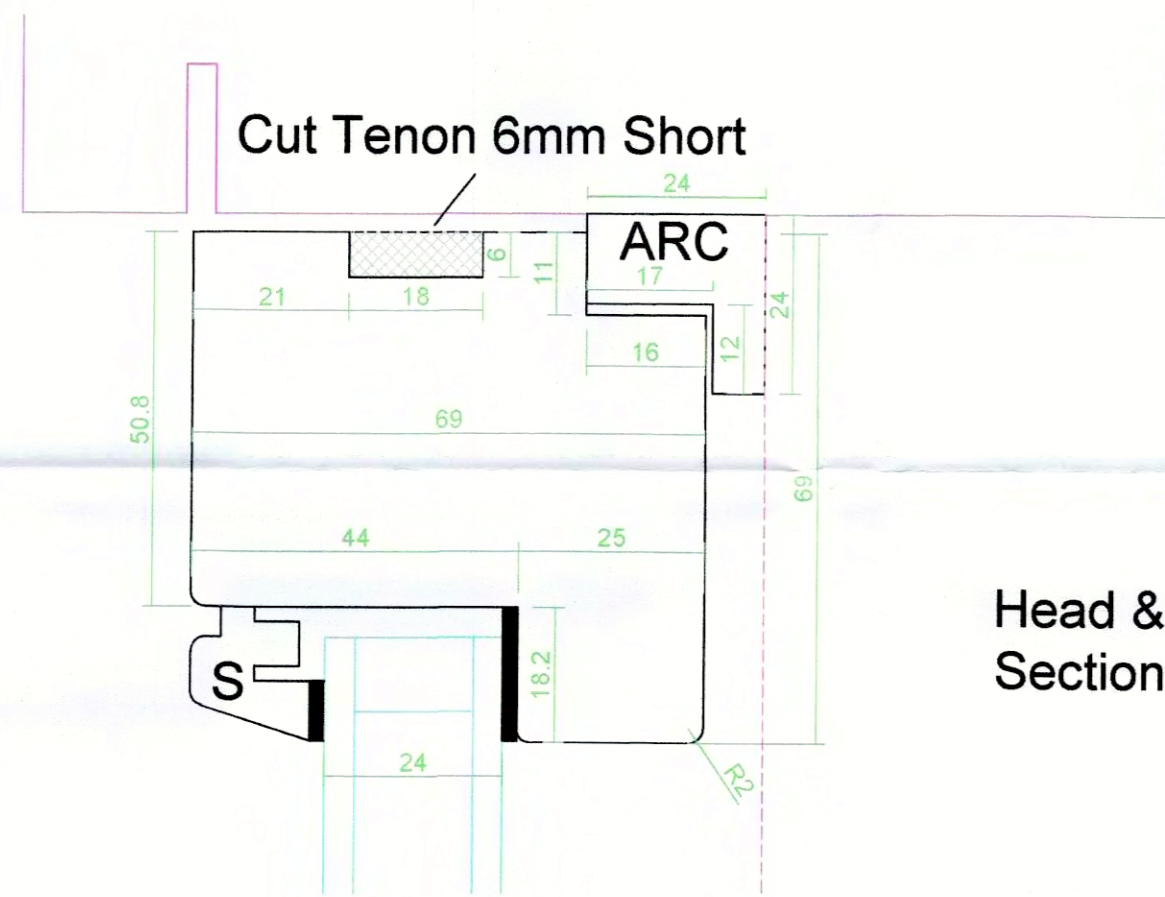
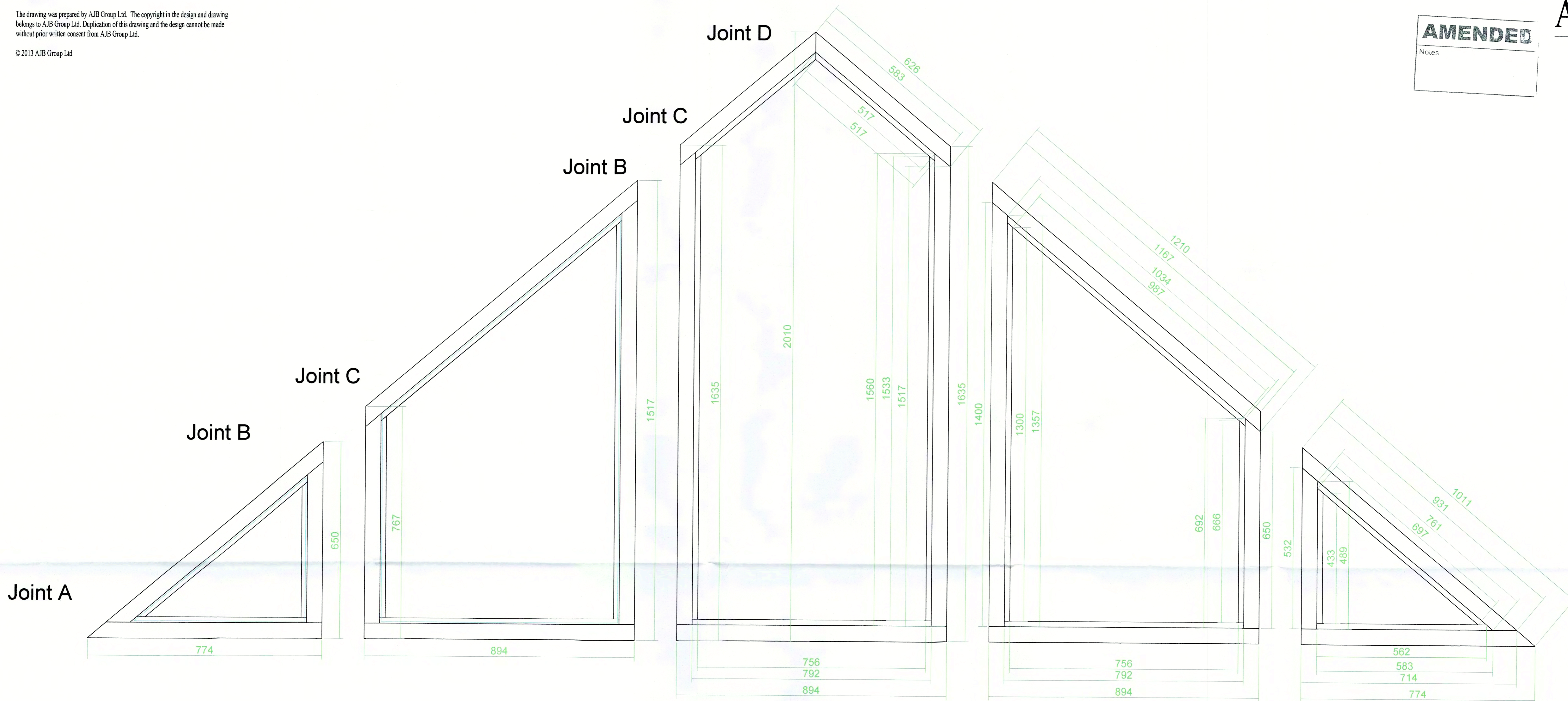

Limb

NYMNP
- 7 JUL 2017

CLIENT Oakwright	PROJECT End Windows
ADDRESS	TITLE Sections & Elevations
	PURPOSE OF ISSUE FM
SCALE 1:10	DATE 22.05.17
DRAWING NO. 210132	REVISION M 01

