

Patchett Joinery Limited  
Ryefield House  
180 Highgate Road  
Bradford  
West Yorkshire  
BD13 1DS



[www.patchett-joinery.co.uk](http://www.patchett-joinery.co.uk)

**Quotation Prepared for**

Mr & Mrs Cross  
Anna & Jeremy Cross

**Sales Contact**

Beverley Ayers

**Billing Address**

Beadle Cottage

Robin Hoods Bay  
YO22 4SF

**Installation or Delivery Address**

Beadle Cottage

Robin Hoods Bay  
YO22 4SF

**Quotation 104233-2 : Beadley Cottage**

Thank you for your recent enquiry, I have pleasure in providing you with your quotation on the following pages. The quotation is made up of 5 sections:

Section A: Notes and assumptions we have made along with a summary of the items.

Section B: Detailed specification of each item.

Section C: Product information and section drawings including options.

Section D: General information about the quotation and other things to consider.

Section E: Acceptance page and your instruction to proceed.

I hope I have interpreted your requirements correctly and trust this quotation meets them. If you require further information or clarification regarding your quotation please contact me, my details are at the top of this page. I will be in contact in the near future and look forward to receiving your further instruction.

Yours sincerely,

Beverley Ayers

## Section A

### Quotation 104233 Notes and Assumptions

- This quote has been compiled on the assumption that the site is in an area of medium exposure and low pollution. If otherwise please advise accordingly so that relevant specification changes can be made to the quotation.
- We have assumed the weights and pulleys sliding sash frame is sat in check by 70mm on either side (140mm overall) leaving 50mm of the frame showing. Please confirm.
- The fitting price is subject to a full survey and may change as a result.

#### Quotation 104233-2 : Beadley Cottage

### Quote Summary

Item	Reference	Dimensions (Overall size mm's)	Qty	Unit Price	Total Price
1	WG1 Lounge	1640X1800	1		
2	DG1 Front Door	930X1870	1		
3	FW1 Bedroom 1	1140X1250	1		
4	WF2 Bathroom	530X840	1		
5	WF3 Bedroom 2	600X1190	1		
		<b>TOTAL</b>	<b>5</b>		

**TOTAL 5**

**VAT**

**TOTAL INCL. VAT**

---

---

# Section B

Quote Reference : 104233-2 | Name : Anna & Jeremy Cross

Quote Description : Beadley Cottage



Item	Reference / Location	Overall WxH	Qty	Unit Price	Total Price
1	WG1 Lounge	1640 x 1800	1		
<p>Sliding Sash - Weights &amp; Pulleys                      Glass: 4/8/4 TUF/TUF Low E                      Spacer: Dark Bronze Aluminium                      Gas: Argon                      Clear Glass                      Beading: Internal Black Tape                      Top Sliding Sash (12)                      Bottom Sliding Sash - no horns (11)                      Hardware - Brass (11)                      Astragal bar spacer: 18mm Dark Bronze                      Astragal Bar width: 25mm                      Int/Ext Coating: 9016 Standard White                      Trickle Vent: White (12)                      Fitting: Gold Service                      Weatherseal: White</p>				<p><b>Frame Sections</b></p> <p>Frame: 58 x 160 Head SSWP2016                      Frame: 68 x 160 Cill                      Frame: 58x160 LH Jamb SSWP2016                      Frame: 58x160 RH Jamb SSWP2016                      Window Board Groove: No                      Cill Nosing: W&amp;P 100x38mm Extended (Extra -124mm)                      Timber: Accoya                      Weight each : 162kg</p>	

Item	Reference / Location	Overall WxH	Qty	Unit Price	Total Price
2	DG1 Front Door	930 x 1870	1		
<p>Product Range: Open In Single Door                      Panel: Insulated, raised &amp; fielded - Hardwood                      Lever Handles: Stella - Polished Brass                      Cylinder: PAS24 - Brass                      Hinges: 3D Adjustable - Gold                      Letterplate: Traditional style for low exposure - Brass                      Ext Coating: 9016 Standard White (0)                      Ext Coating: F&amp;B 265 Manor House Gray (11)                      Int Coating: 9016 Standard White                      Trickle Vent: None                      Fitting: Gold Service                      Weatherseal: White                      Threshold: 20mm                      10 metres @ External Bolection Moulding                      **All Timber Cills to be Oiled with Clear Finish**</p>		<p><b>**All Timber Cills to be Oiled with Clear Finish**</b></p>		<p><b>Frame Sections</b></p> <p>Frame: 58mm Head FD IN                      Frame: Black aluminium threshold                      Frame: 58mm LH Jamb FD IN                      Frame: 58mm RH Jamb FD IN                      Threshold: 20mm (Bottom)                      Timber: Accoya                      Weight each : 63kg</p>	

Quote Reference : 104233-2 | Name : Anna & Jeremy Cross

Quote Description : Beadley Cottage



Item	Reference / Location	Overall WxH	Qty	Unit Price	Total Price
3	FW1 Bedroom 1	1140 x 1250	1		

Yorkshire Slider LH  
 Glass: 4/8/4 TUF/TUF Low E  
 Spacer: Dark Bronze Aluminium  
 Gas: Argon  
 Clear Glass  
 Beading: Internal Black Tape  
 YS LH Opening Sash 2015 (21)  
 YS RH Fixed Sash 2015 (11)  
 Standard Brass Locking Fitch (21)  
 Astragal bar spacer: 18mm Dark Bronze  
 Astragal Bar width: 25mm  
 Int/Ext Coating: 9016 Standard White  
 Yorkshire Slider RH Fixed Sash 2015 (11)  
 Trickle Vent: White  
 Fitting: Gold Service  
 Weatherseal: White YS 2015

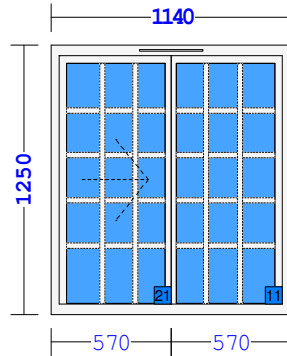

**Frame Sections**

Frame: Head Front 68mm YS  
 Frame: Cill YS  
 Frame: LH Jamb Front End YS  
 Frame: RH Jamb Front End YS  
 Window Board Groove: No  
 Cill Nosing: 80mm  
 Timber: Accoya  
 Weight each : 51kg

Item	Reference / Location	Overall WxH	Qty	Unit Price	Total Price
4	WF2 Bathroom	530 x 840	1		

Sliding Sash - Hidden Balance  
 Glass: 4/8/4 TUF/TUF Low E  
 Spacer: Dark Bronze Aluminium  
 Gas: Argon  
 Obscure Glass: Stippolyte  
 Beading: Internal Black Tape  
 Top Sliding Sash - no horns (12)  
 Bottom Sliding Sash - no horns HB (11)  
 Hardware - Brass (11)  
 Astragal bar spacer: 18mm Dark Bronze  
 Astragal Bar width: 25mm  
 Int/Ext Coating: 9016 Standard White  
 Trickle Vent: White (12)  
 Fitting: Gold Service  
 Weatherseal: White

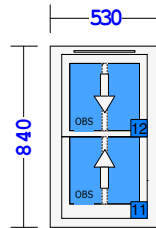

**Frame Sections**

Frame: 80 x 58 Head Front SS  
 Frame: 68 x 160 Cill  
 Frame: 80 x 58 LH Jamb  
 Frame: 80 x 58 RH Jamb  
 Window Board Groove: No  
 Cill Nosing: SS 100x38mm  
 Extended  
 Timber: Accoya  
 Weight each : 23kg

Quote Reference : 104233-2 | Name : Anna & Jeremy Cross

Quote Description : Beadley Cottage

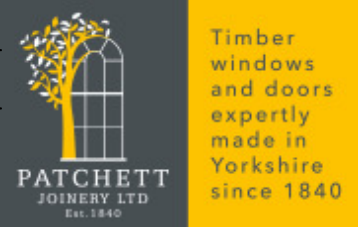

Item	Reference / Location	Overall WxH	Qty	Unit Price	Total Price
5	WF3 Bedroom 2	600 x 1190	1		

Sliding Sash - Hidden Balance  
Glass: 4/8/4 TUF/TUF Low E  
Spacer: Dark Bronze Aluminium  
Gas: Argon  
Clear Glass  
Beading: Internal Black Tape  
Top Sliding Sash - no horns (12)  
Bottom Sliding Sash - no horns HB (11)  
Hardware - Brass (11)  
Astragal bar spacer: 18mm Dark Bronze  
Astragal Bar width: 25mm  
Int/Ext Coating: 9016 Standard White  
Trickle Vent: White (12)  
Fitting: Gold Service  
Weatherseal: White

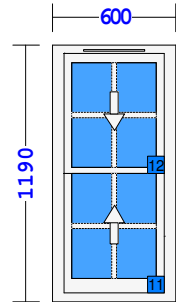

**Frame Sections**

Frame: 80 x 58 Head Front SS  
Frame: 68 x 160 Cill  
Frame: 80 x 58 LH Jamb  
Frame: 80 x 58 RH Jamb  
Window Board Groove: No  
Cill Nosing: SS 100x38mm  
Extended  
Timber: Accoya  
Weight each : 33kg

## Section C

# Product Information: Sliding Sash Window

### Design:

There are two designs of sliding sash windows available:

1. **Concealed Balance Sliding Sash** - A modern design concept where the sashes are controlled by concealed spring balances that are concealed from view when the window is closed.
2. **Weight & Pullies Sliding Sash** - The traditional sliding sash design where the sashes are counter-balanced by weights that are located in the extended frame box section. This window is suited for replacement and/or conservation/heritage projects.

### Hardware:

**Spring Balance:** High quality spring balances that are pre-tensioned to provide the smooth vertical action of the sashes. **(Concealed balance sliding sash only).**

**Axle Pullies:** High quality axle pullies provide smooth operation of the sashes, finished to match the other hardware. **(Weight & Pullies only).**

**Fitch catch:** located on the meeting rail and used to pull the sashes together to maintain compression on the gaskets when the window is closed. The fitch catch is also lockable.

**Sash lift/eye:** High quality hardware to lift or lower the sash.

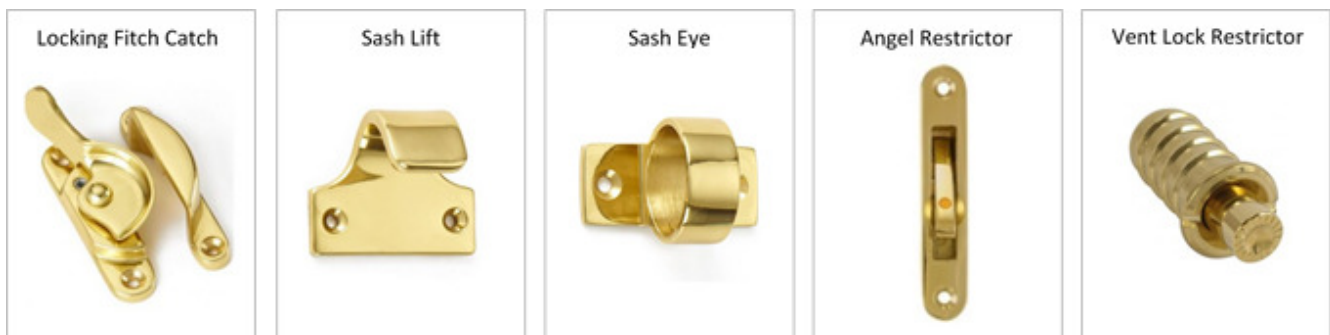

### Hardware options:

**Angel restrictor:** a restrictor that resets itself after every use.

**Vent lock restrictor:** a locking stud that is manually extended to prevent the sash opening more than a pre-determined amount.

**Trickle vents:** to allow background ventilation trickle vents are recessed into the head of the frame. White or brown are the standard colours. **Options:** the vent can be coloured to match paint finish.

**Finishes:** chrome, satin chrome, brass, satin brass. Other finishes are available by special order.

### Frame Sections and Optional Grooves:

**Groove options:** (see drawing below).

**Window board groove:** to locate the internal window bottom.

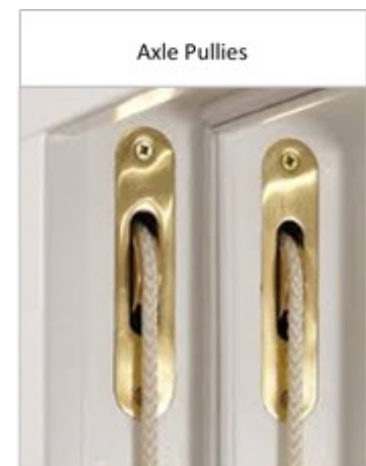

# Sliding Sash: Concealed balances and Weight & Pulley Sections & Frame Options

Vertical Section A-A

Head showing optional concealed trickle vent

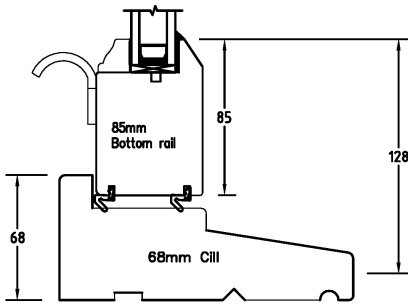
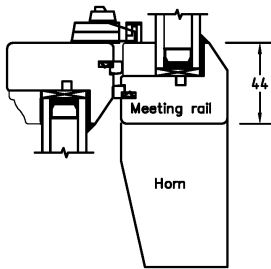
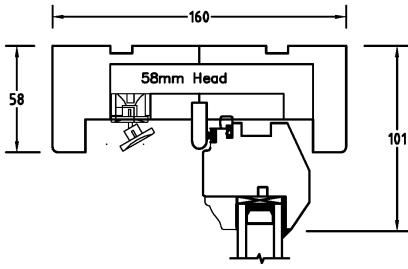

Concealed Balance

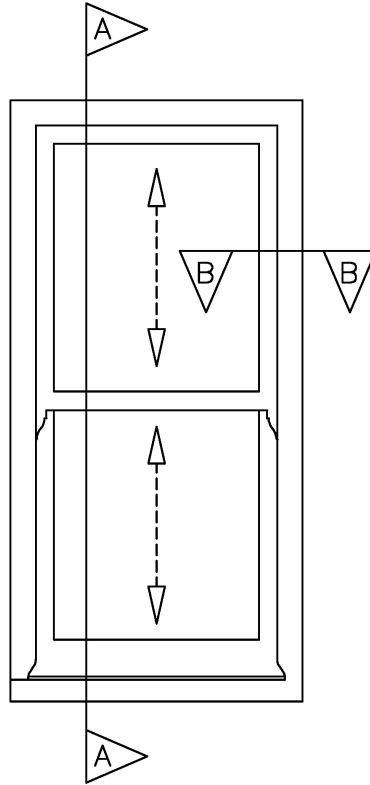

Weight and Pulley

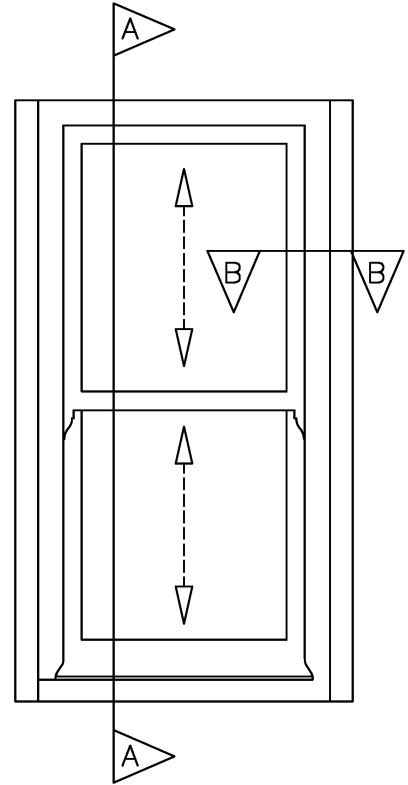

Concealed Balance

Horizontal Section B-B

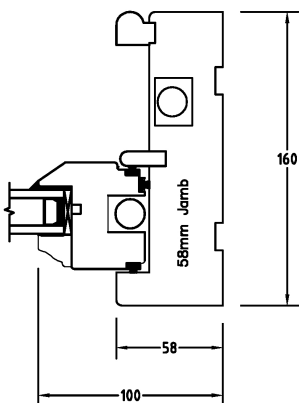

Weight and Pulley

Horizontal Section B-B

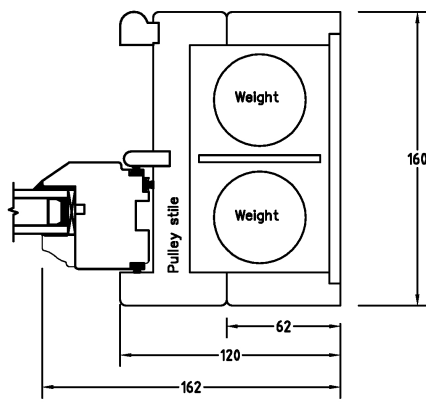

## Frame Options:

Concealed Balance

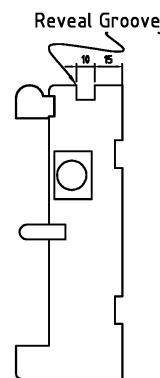

Weight & Pulley

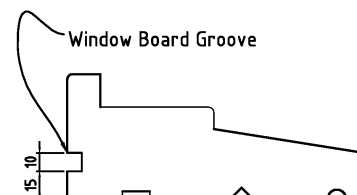
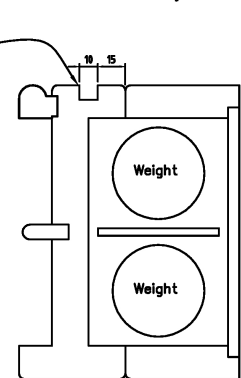

# Product Information: Open In/Out Doorsets

## Design:

58mm thick for added security and thermal improvements. All doors can be integrated with windows to create large entrance screens or barn entrances.

## Hardware:

**3-Dimensional Hinges:** The doors can be adjusted easily during installation and in service with 3D hinges. Optimum door compression, lateral and height placement is guaranteed. Available in different finishes.

**Multi-point Lock:** The latest multi-point locking system providing high security for extra peace of mind.

**Euro-Cylinder:** Anti-bump/snap key cylinders as standard. Suited key option available.

**Lever Handles:** High quality lever handles to compliment the locking system. Available in various finishes.



## Hardware options:

**Restrictor:** The restrictor allows the door leaf to open to 90°. Standard on outward opening doors.

**Georgian Lock:** A multi-point locking system without a lever handle.

**Centre Door Knobs:** Purely decorative, usually used to compliment a Georgian lock.

**Door Knockers / Spy Holes:** Available on request.

**Letter Plates:** Traditional or sleeve type available depending on application.

**Finishes:** chrome, satin chrome, brass, antique black. Other finishes are available by special order. (N.B. Check finishes match across the different hardware items).



## Frame Sections and Door Options:

**Panels:** Doors can be designed with either raised and fielded or flat or grooved panels. These have an insulated core to meet thermal performance requirements.

**Decorative:** Bespoke options, such as bolection moulds are also possible, please call to discuss further.



# OUTWARD OPENING

Vertical Section A-A

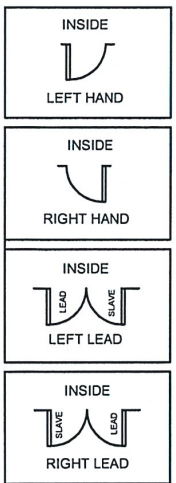
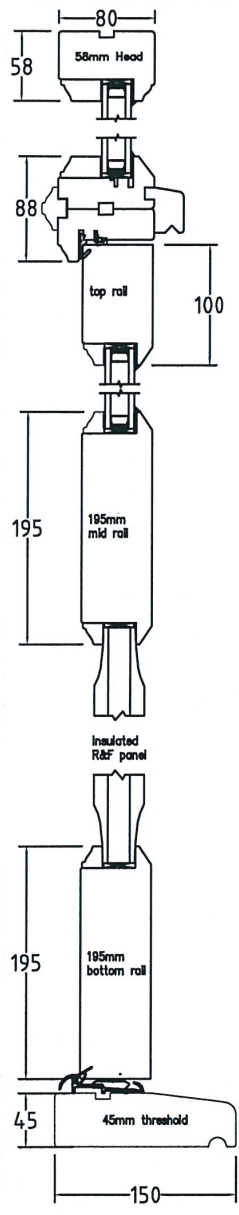

# INWARD OPENING

Vertical Section A-A

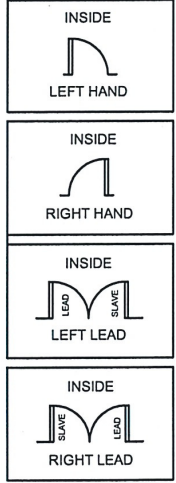
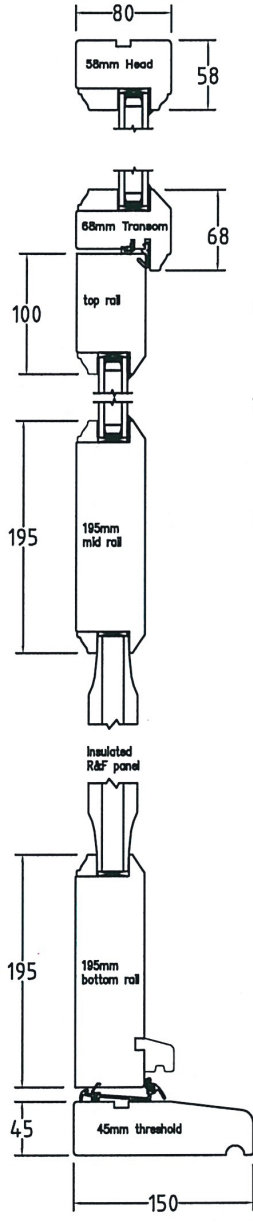

# INWARD OPENING

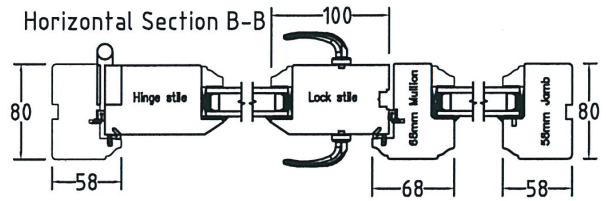

Stable Door Option

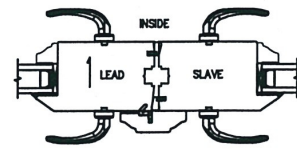
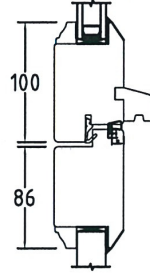

Double Door Option

# OUTWARD OPENING

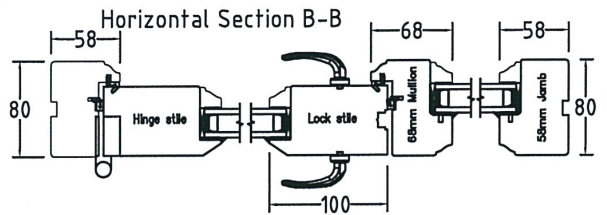

Doorset with sidelight and fanlight

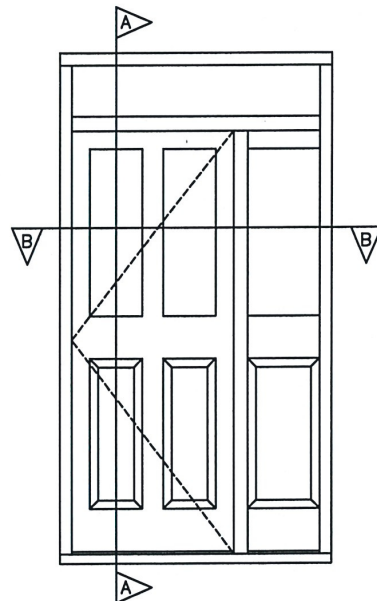

## Section C (continued)

### Timber:

Timber selection is paramount to the effectiveness of any timber product, we use certified timber from well-managed, sustainable forests that are either FSC or PEFC accredited. . The moisture content is optimized for external joinery and monitored throughout the manufacturing process. We also use different species or modified timbers in more vulnerable areas to maximise the longevity of our products. Please note engineered timber achieves its stability as a lamination of layers, subsequently some of these individual pieces maybe visible through the final coating.

**Design:** We design our timber sections to be as slender as possible allowing hardware to operate effectively and without reducing their structural integrity. This maximises the light entering the building, replicates a traditional appearance and allows modern hardware and locking systems to be used.

### Glass:

**4/16/4 Low E:** Our standard specification. 4mm outer pane, 16mm cavity width, 4mm inner pane. Low E indicates a low emissivity coating on the cavity side of the inner pane of the glass unit. This helps prevent heat loss enabling us to achieve a high thermal performance and low u-value.

**Spacer:** The spacer is used to create the cavity width between the glass panes and are available in three finishes, white, black and titanium grey. The spacer create the 'warm edge' to prevent cold bridging and therefore enhance the thermal performance of the double glazed unit.

**Gas:** The type of gas within the cavity of the double glazed unit. Argon is used as standard in most units.

**Safety Glass:** In general, safety glass is used in a critical location. .Standard on external doors; and on windows when the finished floor level is within 800mm. It can come in laminated or toughened form for added security.

**Beading:** all sashes are glazed from the inside to maximise security and provide the longest re-decorating cycle, when no sash is specified the beads are on the outside.

**Astragal Bars:** used to design traditional looking windows that had narrow glazing bars. Small sections of timber either 19mm or 25mm wide are bonded onto the face of the glass. A corresponding spacer is located within the cavity of the double glazed unit.

**Paint:** Our finishing system is designed to comply with BSEN 927-1 'Moderate exposure' if your location is more exposed this will affect the length of the warranty and reduce maintenance intervals. End grain sealer is applied prior to the spray coats to prevent moisture uptake through any exposed end grain. Exposed edges are radiused to provide maximum coating performance. We can also provide a 2-tone finish where the external and internal faces of a product are different colours or stains.

### Installation Service - Gold / Silver / Bronze:

		Gold	Silver	Bronze
1	Survey.	Yes	Yes	Yes
2	Building Regulation Approval.	Yes	No	No
3	Protect floor coverings and lay dust protection	Yes	No	No
4	Remove existing windows/doors and dispose (off site).	Yes	Yes	No
5	Unload delivery vehicle and load out ready for fitting (2 storey building).	Yes	Yes	Yes
6	Fit windows/doors into position and seal apertures (excluding external mastics).	Yes	Yes	Yes
7	Mastic seal (externally)	Yes	Yes	No
8	Fit trims / make good internally	Yes	No	No
9	Replace existing reveals/window board/architraves (confirmed at survey)	Extra	No	No

#### **11. Waiver and variations**

11.1 Any waiver or variation of these terms is binding in honour only unless:

11.1.1 made (or recorded) in writing;

11.1.2 signed on behalf of each party; and

11.1.3 expressly stating an intention to vary these terms.

11.2 All orders that you place with us will be on these terms (or any that we may issue to replace them). By placing an order with us, you are expressly waiving any printed terms you may have to the extent that they are inconsistent with our terms.

#### **12. Force majeure- business customers only**

12.1 If we are unable to perform our obligations to you (or able to perform them only at unreasonable cost) because of circumstances beyond our control, we may cancel or suspend any of our obligations to you, without liability.

12.2 Examples of those circumstances include act of God, accident, explosion, war, terrorism, fire, flood, transport delays, strikes and other industrial disputes and difficulty in obtaining supplies.

#### **13. Performance**

13.1 Unless otherwise agreed in writing you must, at no cost to us:

13.1.1 erect, maintain, dismantle and move all scaffolding and plant required for the work;

13.1.2 provide any water supply, artificial lighting and electric power required for the work;

13.1.3 unload goods, plant and material immediately on arrival at the place of delivery and provide secure and dry storage and other reasonable facilities; and

13.1.4 ensure that all safety, health, welfare facilities and arrangements (where applicable) comply with current health and safety legislation.

13.2 You must keep all joinery supplies in well stored and dry place. White joinery supplies must be primed or stained immediately on receipt. Any subsequent cut service must be primed or stained before fixing in position.

13.3 We shall carry out work on a continuous basis during normal working hours (see clause 2.3) and the price is fixed accordingly. We will make additional charges if we are:

13.3.1 denied access;

13.3.2 waiting on site; and returning on site to commence or continue work due to clauses 13.3.1 and 14.3.2.

#### **14. General**

14.1 English law is applicable to any contract made under these terms. The English and Welsh courts have non-exclusive jurisdiction.

14.2 Any dispute arising out of the contract may be referred to the arbitration of an agreed arbitrator, or, failing that, an arbitrator appointed by the Chartered Institute of Arbitrators.

14.3 If you are more than one person, each of you is liable for all of your obligations under these terms (joint and several liability).

14.4 If any of these terms are unenforceable as drafted:

14.4.1 it will not affect the enforceability of any other of these terms; and

14.4.2 if it would be enforceable if amended, it will be treated as so amended.

14.5 We may treat you as insolvent if:

14.5.1 you are unable to pay your debts as they fall due; or

14.5.2 you (or any item of your property) becomes the subject of:

a. any formal insolvency procedure (examples of which include receivership, liquidation, administration, voluntary arrangements (including a moratorium) or bankruptcy);

b. any application or proposal for any formal insolvency procedure; or

c. any application, procedure or proposal overseas with similar effect or purpose.

14.6 Business customers only: all brochures, catalogues and other promotional materials are to be treated as illustrative only. Their contents form no part of any contract between us and you should not rely on them in entering into any contract with us.

14.7 Business customers only: any notice by either of us which is to be served under these terms may be served by leaving it at or by delivering it to (by first class post or by fax) the other's registered office or principal place of business. All such notices must be signed.

14.8 No contract will create any right enforceable (by virtue of the Contracts (Rights of Third Parties) Act 1999) by any person not identified as the buyer or seller.

14.9 The only statements upon which you may rely in making the contract with us are those made in writing by someone who is our authorised representative and either:

14.9.1 contained in our estimate (or any covering letter) and not withdrawn before the contract is made; or which expressly state that you may rely on them when entering into the contract.

14.10 Please note that we may transfer personal information about you to those we may appoint to administer your account or recover amounts owing. That may include, for example, passing information about you to our insurers, debt recovery agents and solicitors, if you fail to pay us.