

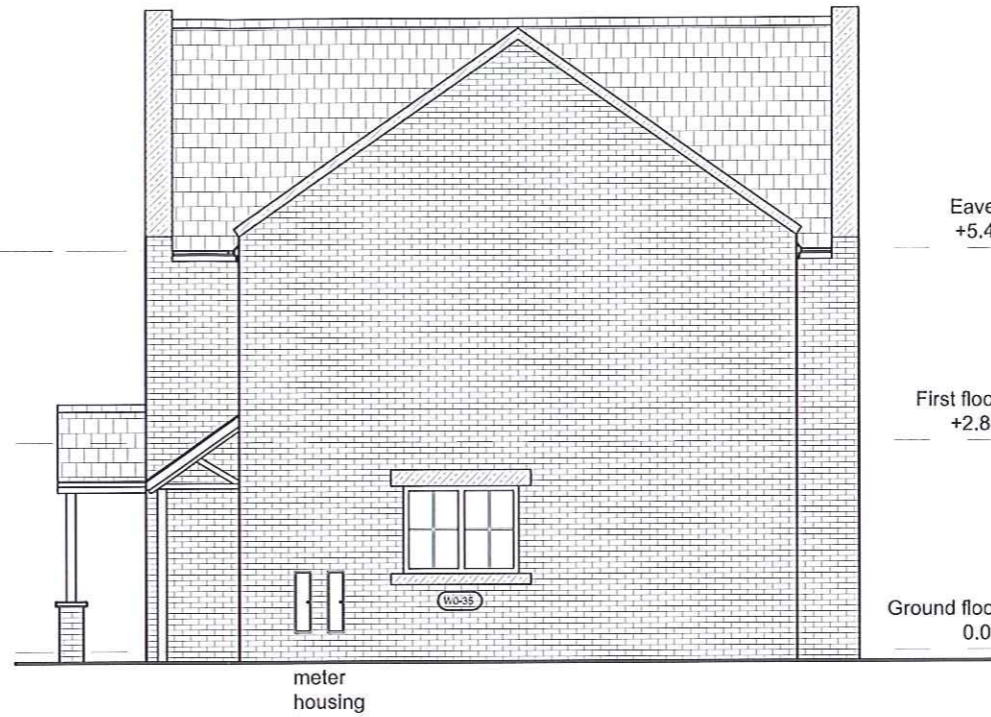

Front (North) Elevation

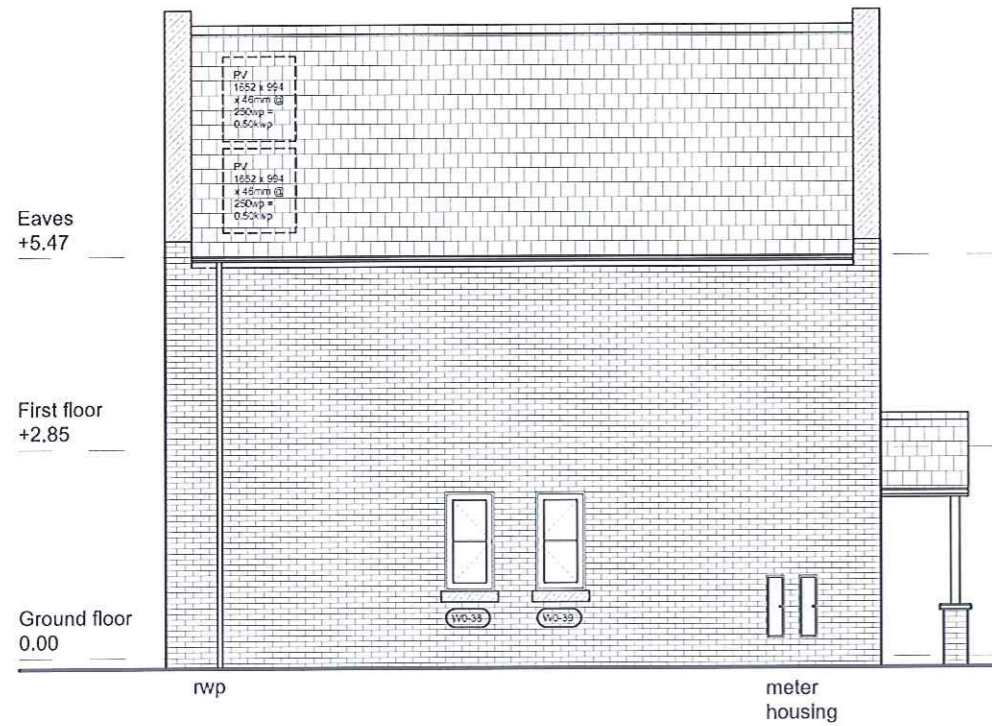

Side (West) Elevation



Side (East) Elevation



Rear (South) Elevation

NOTE:

Roof: Sandtoft Old english clay Pantile in red.

Eaves & verges: Pointed red-brick coursing & natural York sandstone parapets.





Rainwater goods: Heavy-grade uPVC half-round gutters on PPC aluminium gutter spikes, round rainwater pipes and accessories black

External Walls: Red multi clay facing brick. Natural York sandstone heads & cills to windows.

External windows: uPVC casement windows with double glazed units. Colour: RAL 1013 (Cream)

Bedroom Windows: Opening size to first floor windows to be over 0.46m2 per unit.

KEY

-  Clay roof tile
-  Facing brick - Red multi
-  Stonework
-  External windows
-  External doors

STAGE 1	Information/ Comments	✓
STAGE 2	Construction	

REVISIONS

This design is copyright ©

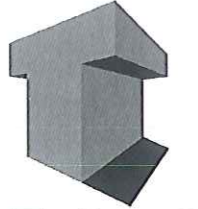

**Tolent**

PROP'D FAMILY HOUSING  
SCRAPER LANE  
STAINSACRE, N. YORKS.

ELEVATIONS  
(PLOT 5 & 6)

Drawn: JMM Scale: 1:100@A3  
Date: APR 12 Checked: GJ

**brewsterbye architects**

5 NORTH HILL ROAD  
HEADINGLEY  
LEEDS  
LS6 2EN

Telephone: 0113 2754500  
Facsimile: 0113 2844290  
Email: info@brewsterbye.co.uk



Dwg No: 422/01(03)310 C

HYMOPA  
11.11.12



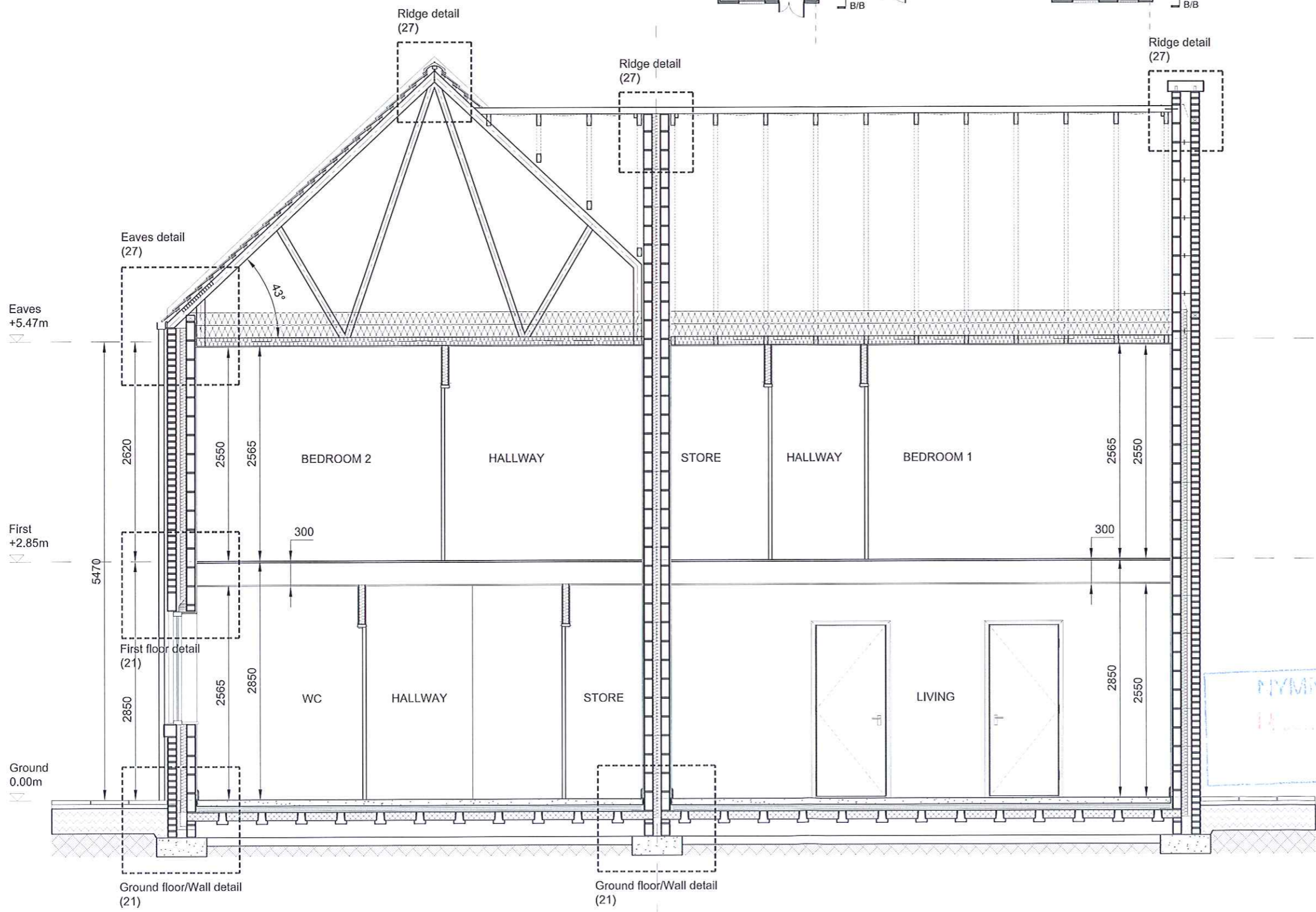
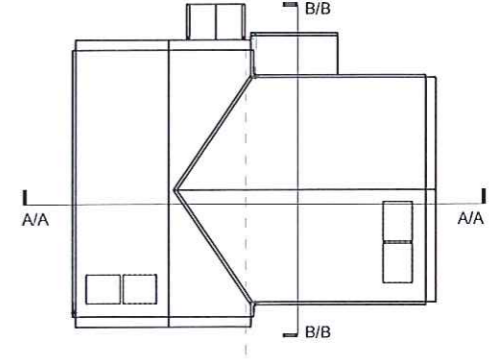
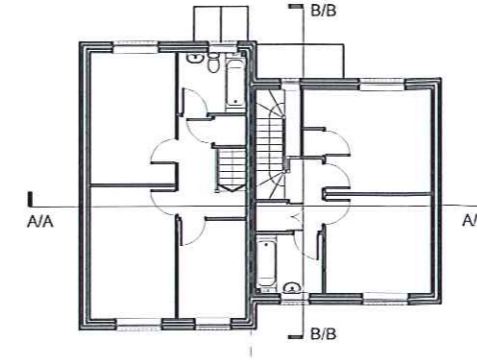
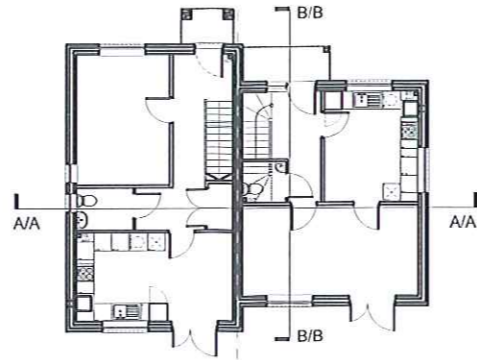

**STAGE 1** ✓  
Information/ Comments

**STAGE 2**  
Construction

REVISIONS  
This design is copyright ©

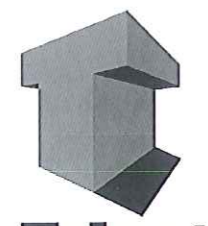

**Tolent**

PROP'D FAMILY HOUSING  
SCRAPER LANE  
STAINSACRE, N. YORKS.

BUILDING SECTION  
PLOT 1 & 2  
SECTION A-A NORTH

Drawn: JMM Scale: 1:50@A3  
Date: APR Checked: GJ

**brewsterbye architects**  
5 NORTH HILL ROAD  
HEADINGLEY  
LEEDS  
LS6 2EN  
Telephone: 0113 2756000  
Fax: 0113 2544250  
Email: info@brewsterbye.co.uk

Dwg No: 422/01(03)500 C

NYMNP  
14.11.22



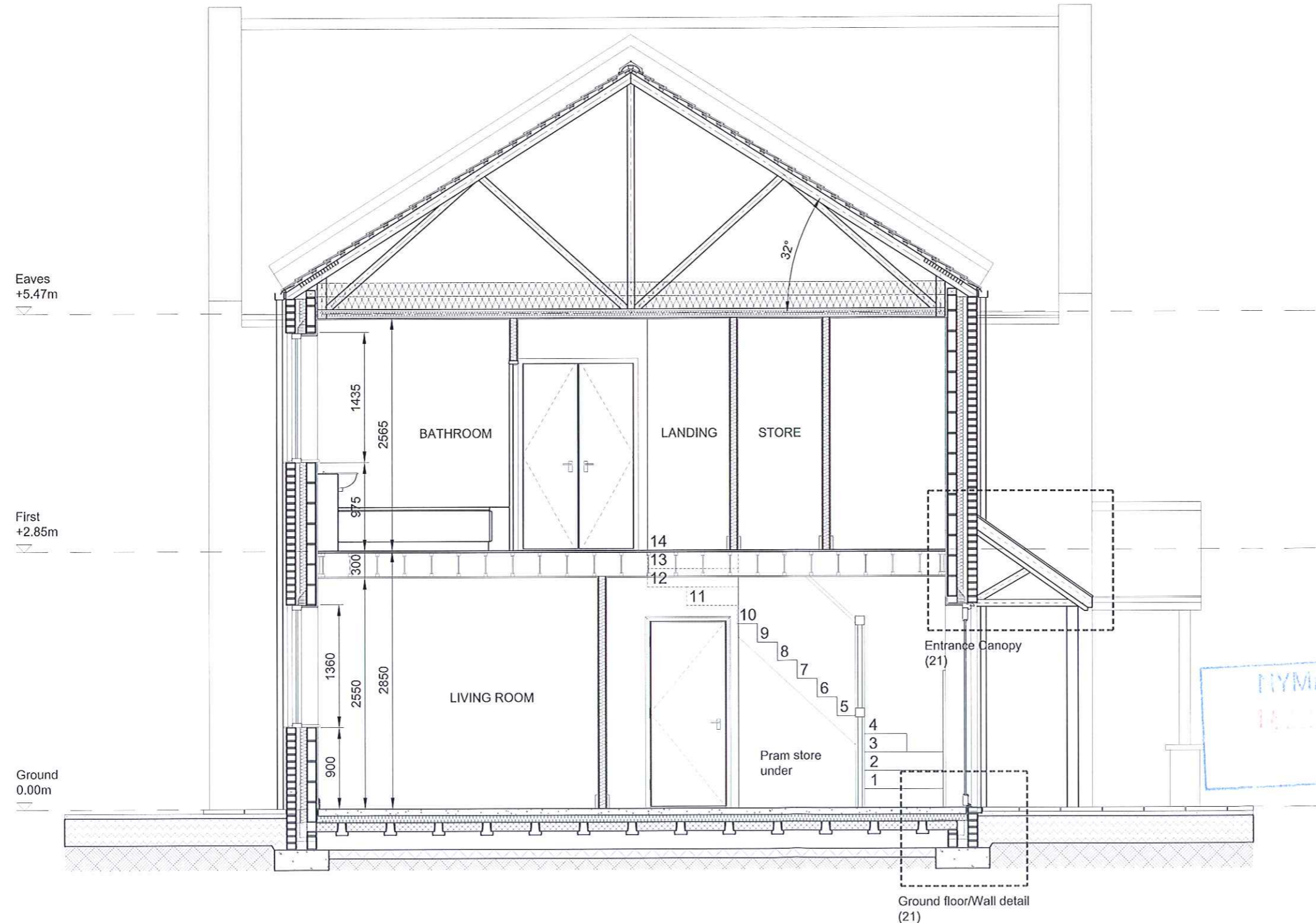
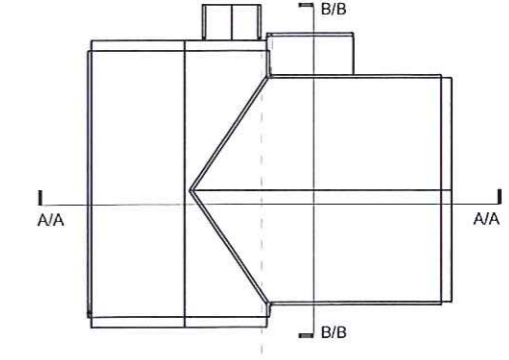
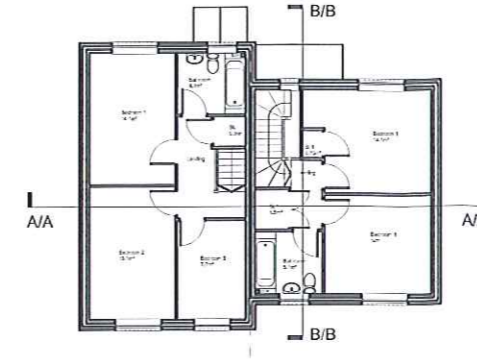

**STAGE 1** ✓  
Information/ Comments

**STAGE 2**  
Construction

REVISIONS  
This design is copyright ©



**Tolent**  
PROP'D FAMILY HOUSING  
SCRAPER LANE  
STAINSACRE, N. YORKS.

**BUILDING SECTION**  
PLOT 1 & 2  
SECTION B-B WEST

Drawn: JMM Scale: 1:50@A3  
Date: APR Checked: GJ

**brewsterbye architects**  
5 NORTH HILL ROAD  
HEADINGLEY  
LEEDS  
LS6 2EN  
Telephone: 0113 2756000  
Facsimile: 0113 2844250  
E-mail: info@brewsterbye.co.uk

Dwg No: 422/01(03)501 B

HYMNPA  
14.03.22

Ground floor/Wall detail (21)





- Site boundary
- D.O.T. type standard tarmac. Shared surface court
- Grassed areas
- 600 x 600mm Paving slab (Marshall Perfecta, Natural or similar)
- Block pavior surfacing in herringbone pattern with contrasting edge block. Colours: Burnt Ochre & Burnt Umber. (Marshall Keyblock, or similar).
- Parking space (V) visitor priary
- Low-level hardy shrubbery maintained at max. 800mm high to maintain visibility across the site.
- Existing tree/bush retained.
- Existing tree/bush removed.
- New tree. (species l.b.c.)
- New dwelling
- Garden shed & secure cycle store to SOD standards. Shed to have concrete base.
- Enclosed rear garden
- 900mm high close-board timber fencing between gardens
- 1.8m high timber hit & miss fencing/privacy screen
- 1.2m high timber post & rail fencing with rabbit-wire infill
- 600mm high timber knee-rail to front gardens.
- 1.2m high timber post & rail fencing with rabbit-wire infill. Shrubbery margin to field-side.
- Domestic refuse bins (general & recycling).
- Spot-level
- Extent of kerbing as per Detail (A) opposite
- Rumble strip with block pavior and keyblock edge to site entrance

**NOTE: LEVELS & CONTOURS TO BE VERIFIED BY CONTRACTOR PRIOR TO CONSTRUCTION. ANY DISCREPANCIES NOTIFIED TO THE EMPLOYER'S AGENT**

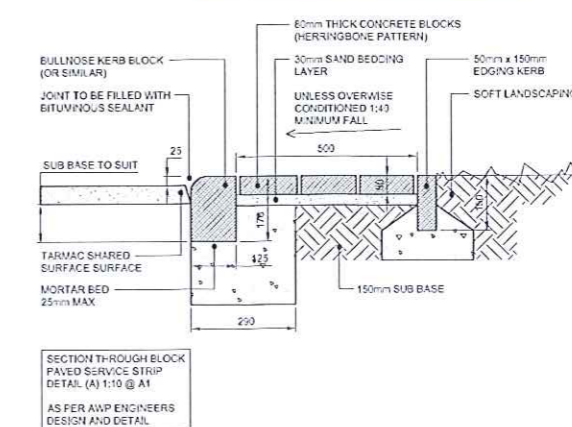

<b>STAGE 1</b> Information/ Comments	✓
<b>STAGE 2</b> Construction	

REVISIONS

This design is copyright ©

**PROP'D FAMILY HOUSING  
SCRAPER LANE,  
STAINSFORD, N.YORKS.**

**SITE PLAN  
EXTERNAL WORKS**

Drawn: JWM      Scale: 1:200 @ A1  
Date: APR 12      Checked: GJ

**brewsterbye architects**  
5 NORTH HILL ROAD  
HEADINGLEY  
LEEDS  
LS28 5EN

Dwg No: 422/01(09)004 C



**NOTES**

1. Do not scale from this drawing. All dimensions must be checked on site by the Contractor prior to the commencement of any fabrication or building works. Where applicable, dimensions and details are to be read in conjunction with specialist consultants' drawings and/or other specifications; any disparity is to be brought to the attention of contractor prior to the commencement of any fabrication or building works.

NYM/NPA  
14.02.2022

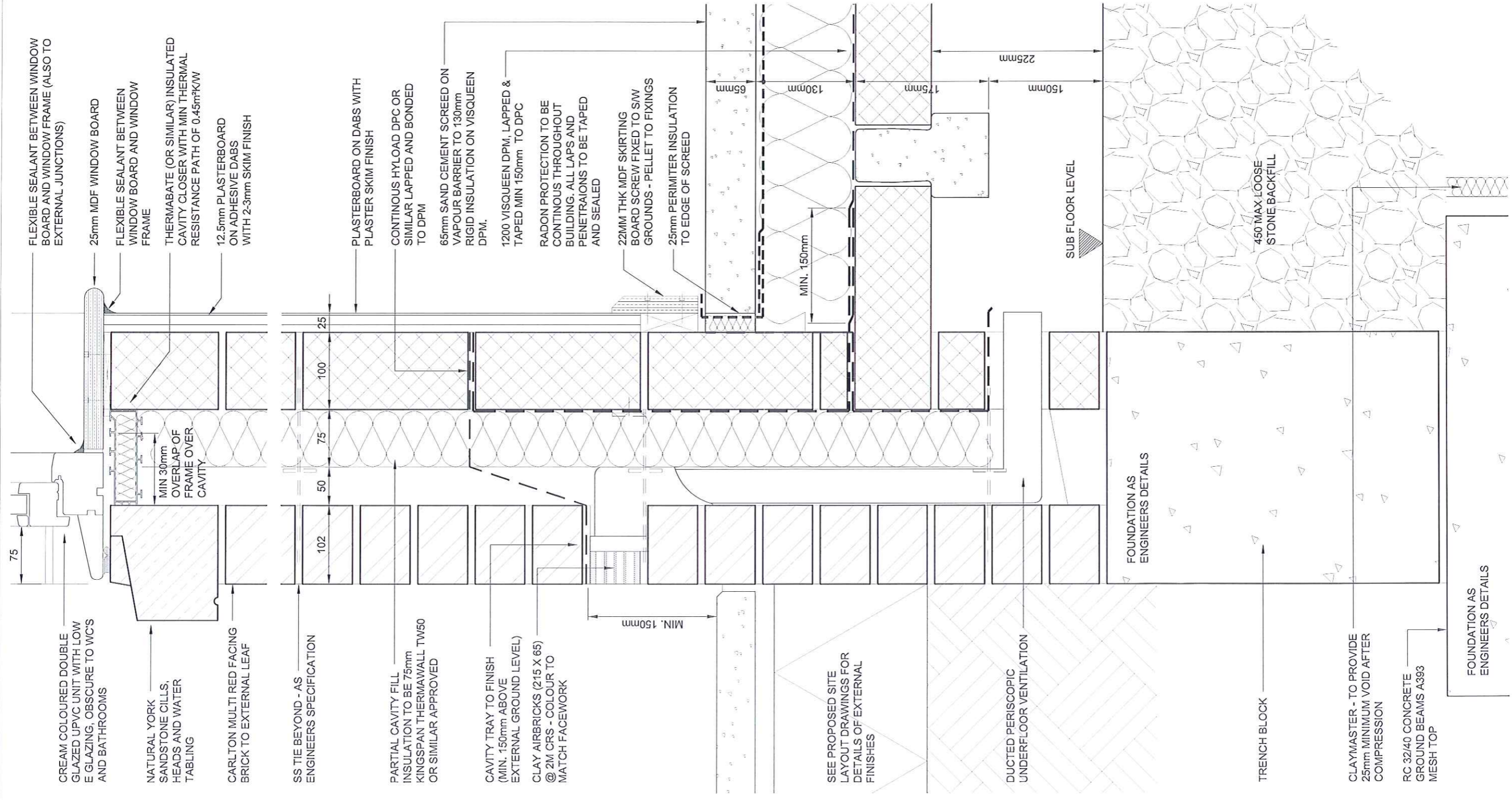

<b>STAGE 1</b>	Information/ Comments	✓
<b>STAGE 2</b>	Construction	

REVISIONS

This design is copyright ©



**Tolent**

PROP'D FAMILY HOUSING  
SCRAPER LANE  
STAINSACRE, N.YORKS.

**EXTERNAL WALL /  
GROUND FLOOR JUNCTION  
& WINDOW CILL**

Drawn: JMM      Scale: 1:5 @ A3  
Date: APR 12      Checked: GJ

**brewsterbye architects**

5 NORTH HILL ROAD  
HEADINGLEY  
LEEDS  
LS9 2EN  
0113 272 000  
0113 284 250  
info@brewsterbye.co.uk

Dwg No: 422/01(21)001 B



**NOTES**

1. Do not scale from this drawing. All dimensions must be checked on site by the Contractor prior to the commencement of any fabrication or building works. Where applicable, dimensions and details are to be read in conjunction with specialist consultants' drawings and/or other specifications; any disparity is to be brought to the attention of contractor prior to the commencement of any fabrication or building works.

NYM/NPA  
14.03.2022

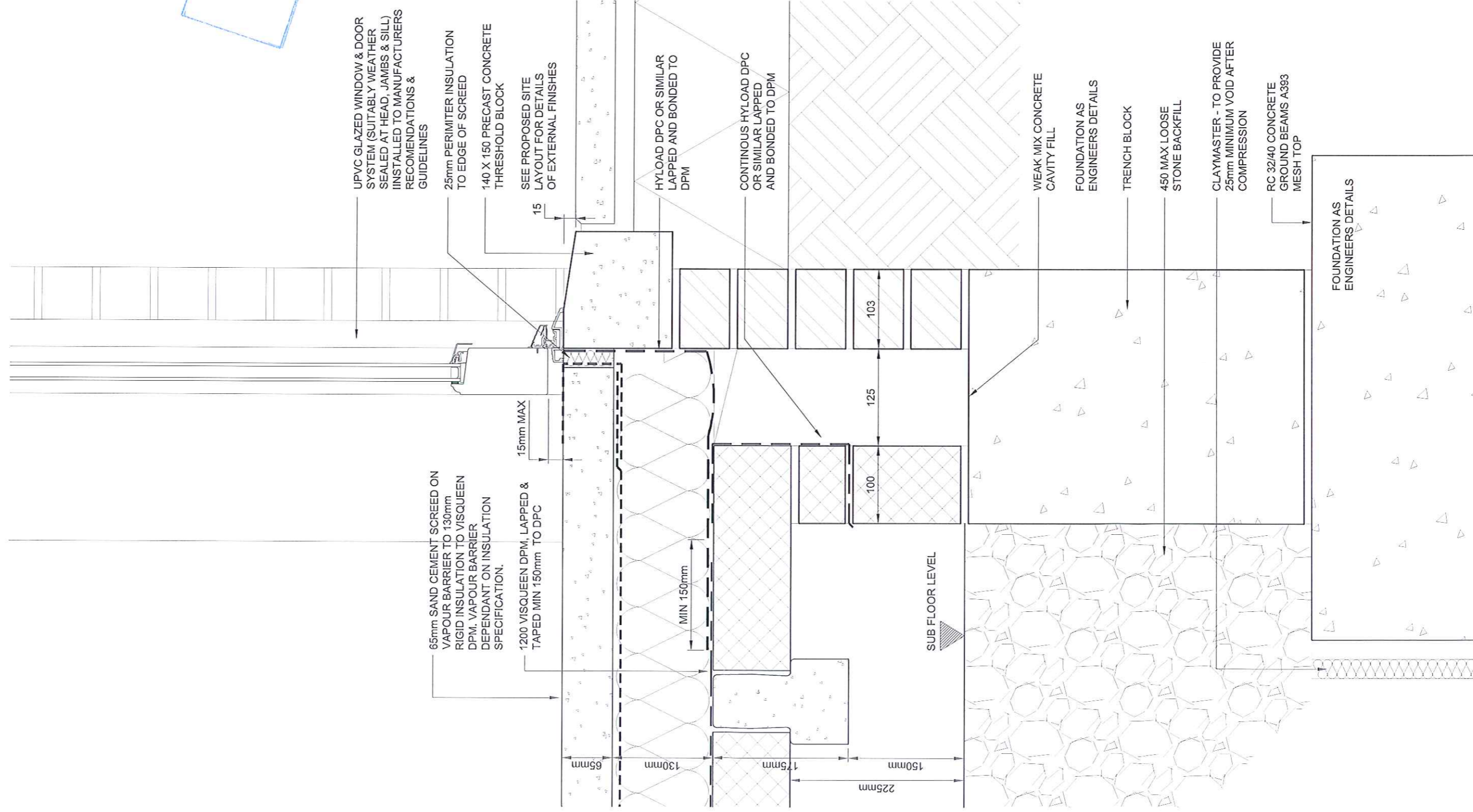

**STAGE 1**  
Information/ Comments



**STAGE 2**  
Construction

REVISIONS

This design is copyright ©

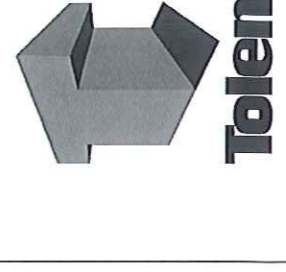

**PROP'D FAMILY HOUSING**  
**SCRAPER LANE**  
STAINSACRE, N.YORKS.

**EXTERNAL WALL/  
GROUND FLOOR  
LEVEL THRESHOLD**

Drawn: JMM Scale: 1:5 @ A3  
Date: APR 12 Checked: GJ



Dwg No: 422/01(21)002 B



**NOTES**

1. Do not scale from this drawing. All dimensions must be checked on site by the Contractor prior to the commencement of any fabrication or building works. Where applicable, dimensions and details are to be read in conjunction with specialist consultants' drawings and/or other specifications; any disparity is to be brought to the attention of contractor prior to the commencement of any fabrication or building works.

N.Y.M.N.F.A.  
 14 APR 2012

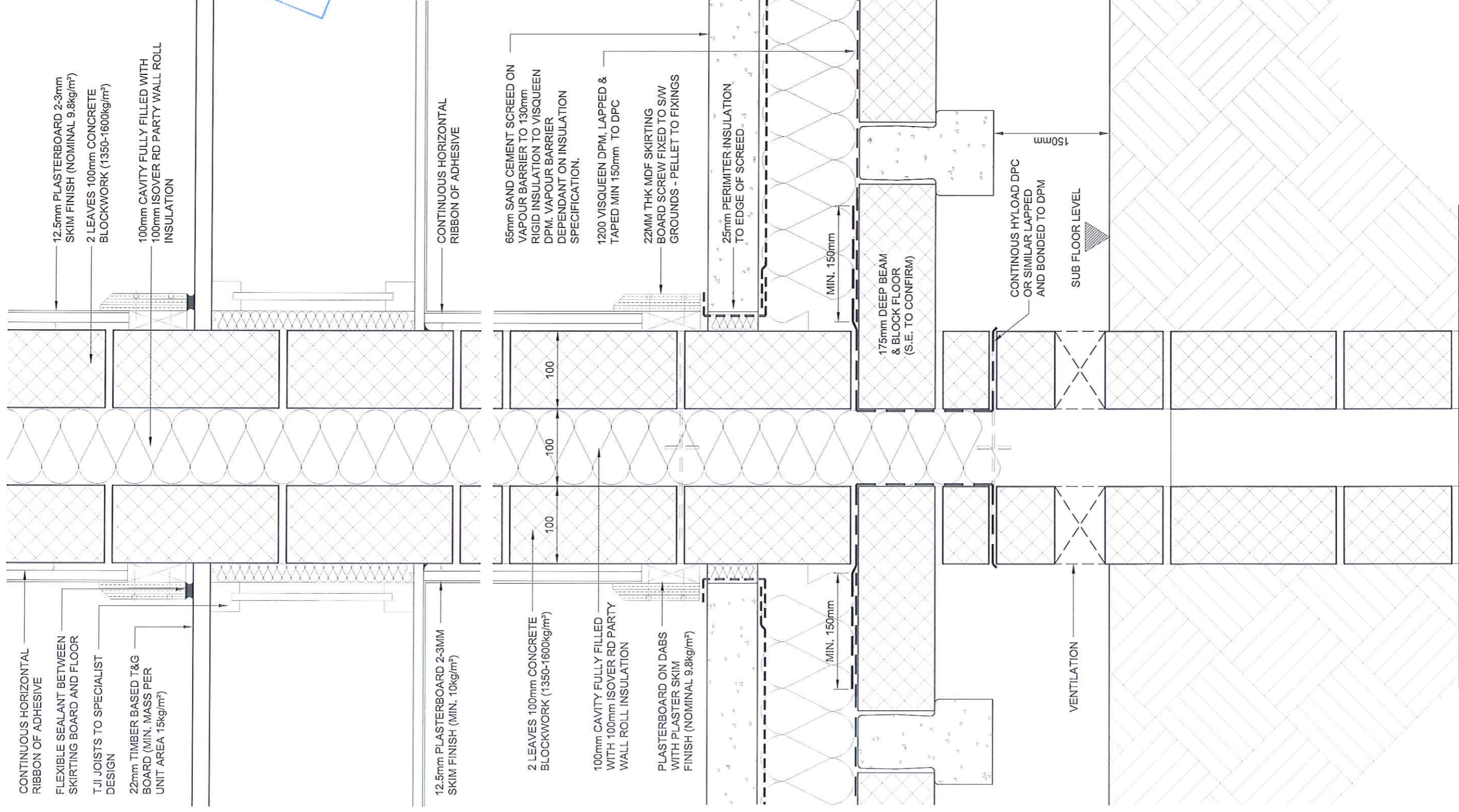

<b>STAGE 1</b>	✓
Information/ Comments	
<b>STAGE 2</b>	
Construction	
REVISIONS	

This design is copyright ©



**Tolent**

PROP'D FAMILY HOUSING  
SCRAPER LANE  
STAINSACRE, N.YORKS

PARTY WALL/  
GROUND FLOOR  
PARTY WALL DETAIL

Drawn: JMM    Scale: 1:5 @ A3  
 Date: APR 12    Checked: GJ

**brewsterbye** architects

5 NORTH HILL ROAD  
 HEADINGLEY  
 LEEDS  
 LS6 2EN  
 0113 2594000  
 0113 2540250  
 info@brewsterbye.co.uk

Dwg No: 422/01(21)003 C

FOUNDATION AS  
ENGINEERS DETAILS



**NOTES**

1. Do not scale from this drawing. All dimensions must be checked on site by the Contractor prior to the commencement of any fabrication or building works. Where applicable, dimensions and details are to be read in conjunction with specialist consultants' drawings and/or other specifications; any disparity is to be brought to the attention of contractor prior to the commencement of any fabrication or building works.

HYMMPA  
14 JUL 2022

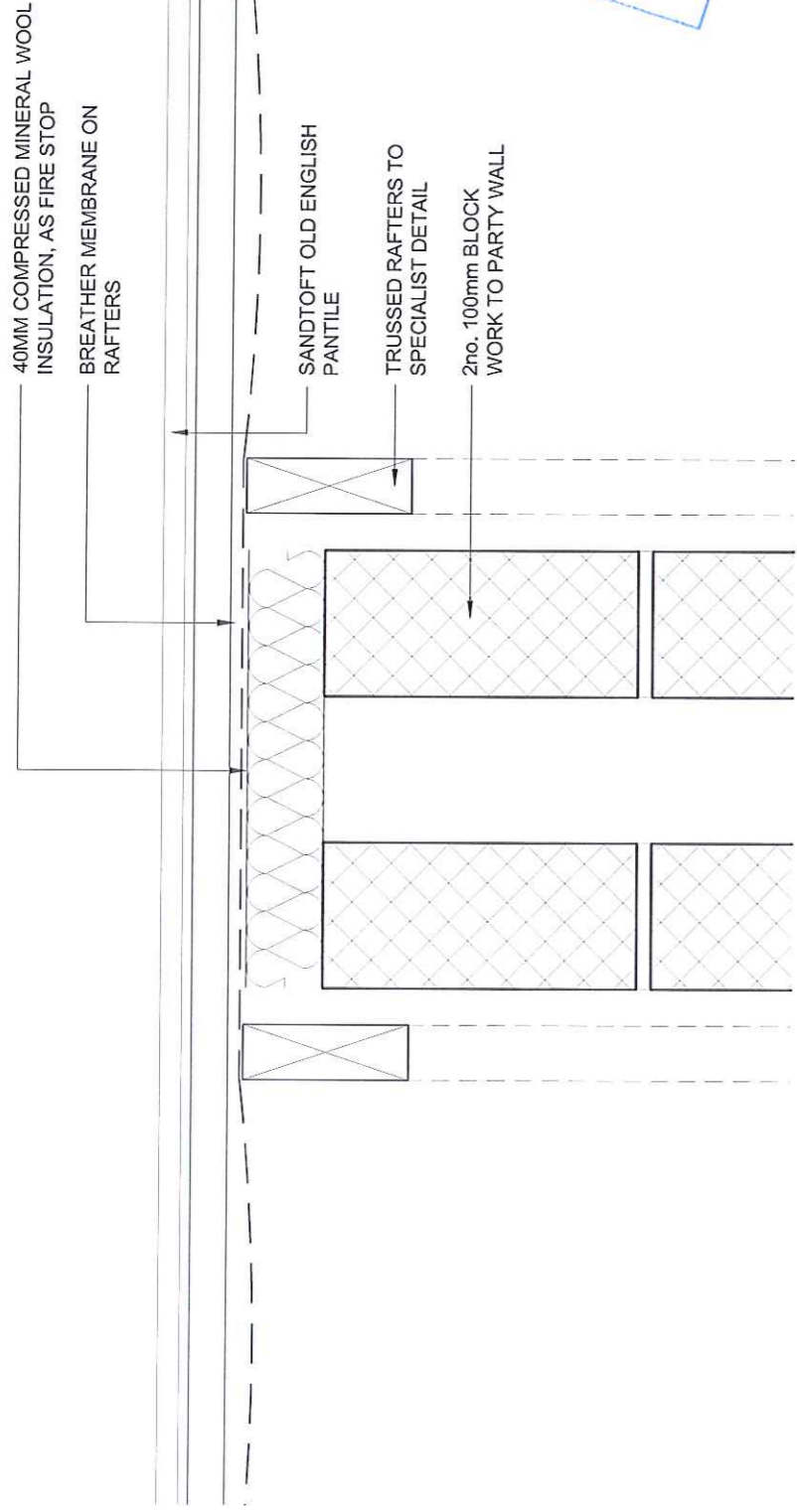

**SECTION**  
SCALE 1:5

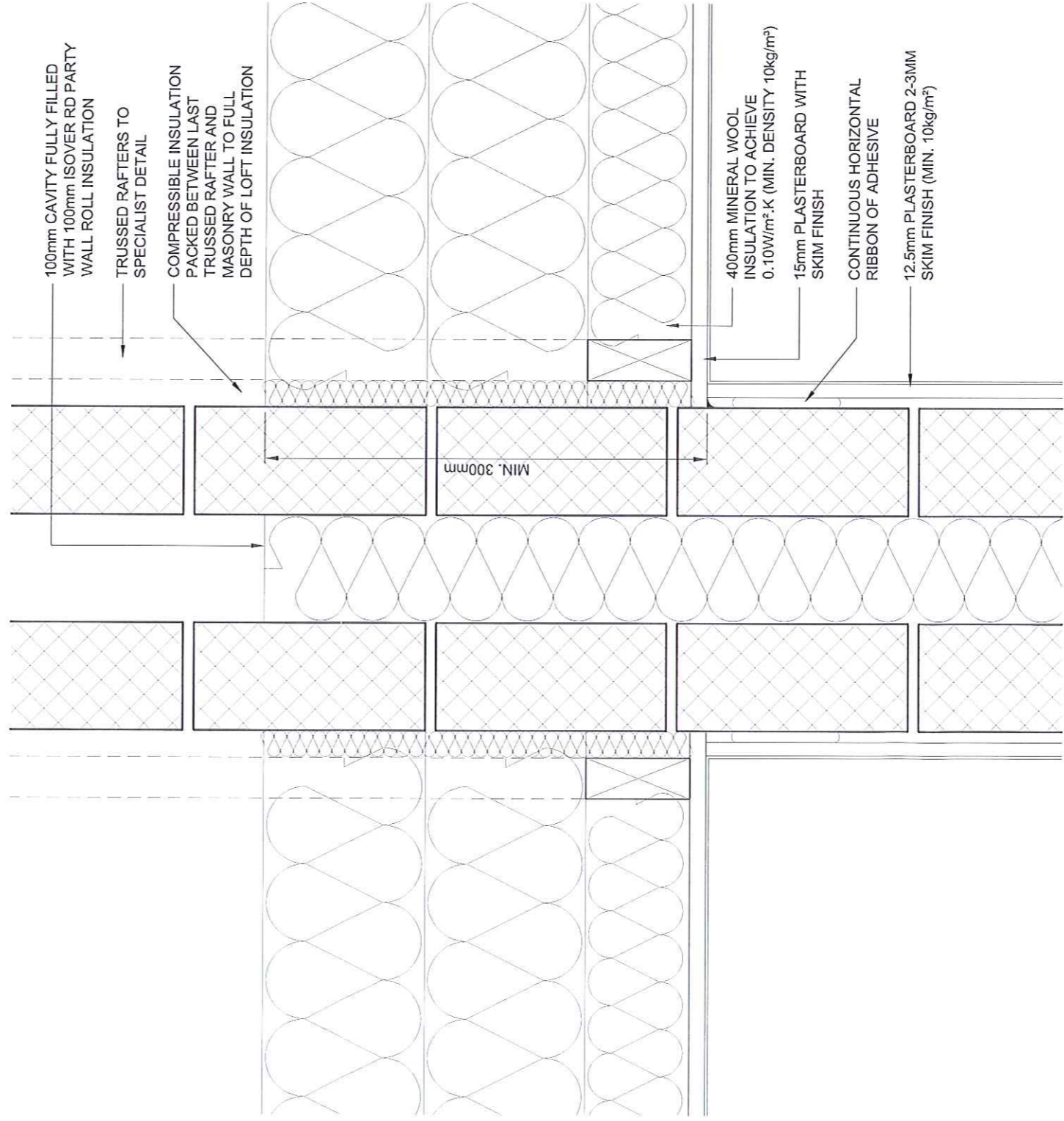

**SECTION**  
SCALE 1:5

<b>STAGE 1</b> Information/ Comments	✓
<b>STAGE 2</b> Construction	

This design is copyright ©

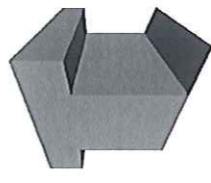

**Toletm**

PROP'D FAMILY HOUSING  
SCRAPER LANE  
STAINSACRE, N.YORKS.

**PARTY WALL/  
CEILING & ROOF JUNCTION  
DETAILS**

Drawn: JMM Scale: 1:5 @ A3  
Date: APR 12 Checked: GJ

**brewsterbye** architects  
5 NORTH HILL ROAD  
HEADINGLEY  
LEEDS  
LS6 2EN  
0113 2774000  
info@brewsterbye.co.uk  
www.brewsterbye.co.uk

Dwg No: 422/01(21)004 C



**NOTES**

1. Do not scale from this drawing. All dimensions must be checked on site by the Contractor prior to the commencement of any fabrication or building works. Where applicable, dimensions and details are to be read in conjunction with specialist consultants' drawings and/or other specifications; any disparity is to be brought to the attention of contractor prior to the commencement of any fabrication or building works.

NYM/NPA  
14 JUL 2022

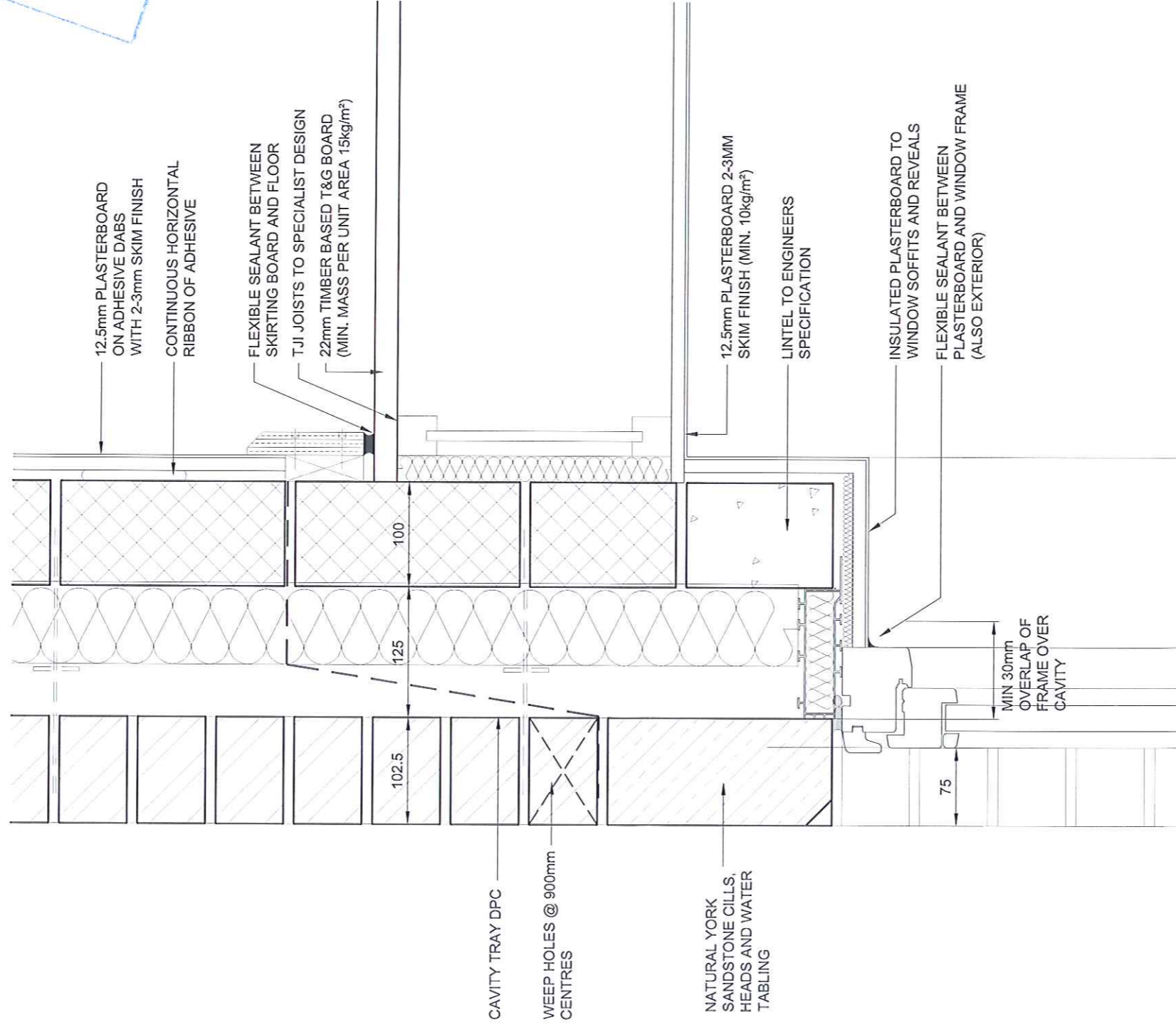

**STAGE 1**  
Information/ Comments

**STAGE 2**  
Construction

REVISIONS

This design is copyright ©

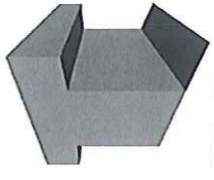

**Tolent**

PROP'D FAMILY HOUSING  
SCRAPER LANE  
STAINSACRE, N.YORKS.

EXTERNAL WALL/  
& WINDOW HEAD  
(IN STONE)

Drawn: JMM Scale: 1:5 @ A3  
Date: APR 12 Checked: GJ



**brewsterbye** architects

5 NORTH HILL ROAD  
HEADINGLEY  
LEEDS  
LS6 2EN

Mobile: 07958 000000  
Fax: 0113 294420  
info@brewsterbye.co.uk

Dwg No: 422/01(21)005 C



**NOTES**

1. Do not scale from this drawing. All dimensions must be checked on site by the Contractor prior to the commencement of any fabrication or building works. Where applicable, dimensions and details are to be read in conjunction with specialist consultants' drawings and/or other specifications; any disparity is to be brought to the attention of contractor prior to the commencement of any fabrication or building works.

LYMNPA  
 14 JUL 2022

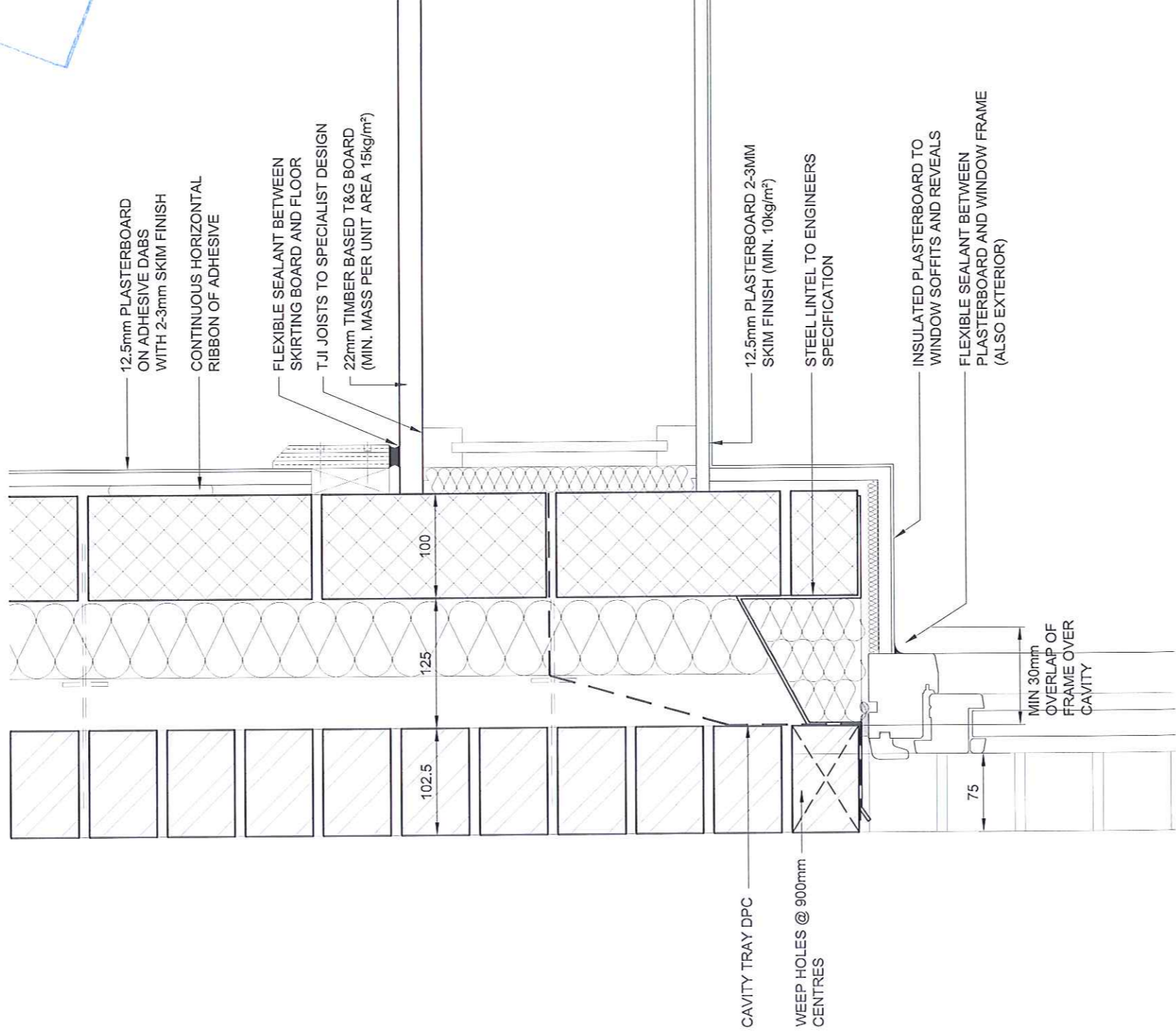

<b>STAGE 1</b> Information/ Comments	✓
<b>STAGE 2</b> Construction	

REVISIONS  
This design is copyright. ©



**Tolent**  
 PROP'D FAMILY HOUSING  
 SCRAPER LANE  
 STAINESACRE, N.YORKS.

**EXTERNAL WALL/  
 & WINDOW HEAD  
 (IN BRICK)**

Drawn: JMM      Scale: 1:5 @ A3  
 Date: APR 12      Checked: GJ

**brewsterbye** architectes  
 5 NORTH HILL ROAD  
 HEADINGLEY  
 LEEDS  
 LS6 2EN  
 Telephone: 0113 2754008  
 Fax: 0113 2844250  
 e-mail: info@brewsterbye.co.uk

Dwg No: 422/01(21)006 C



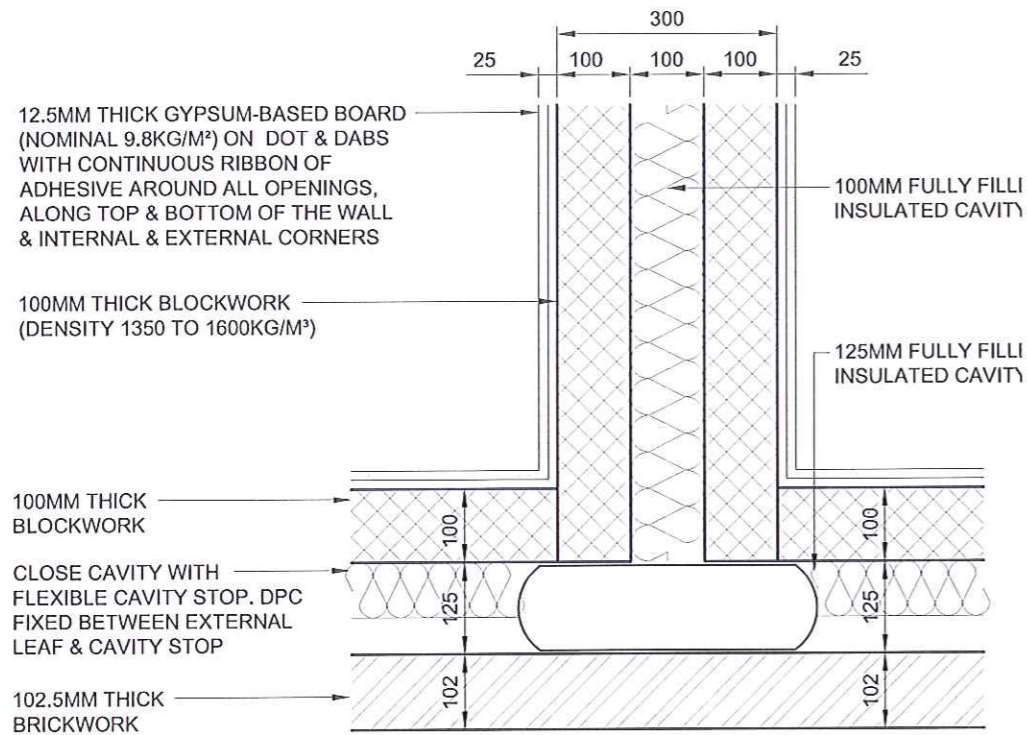

(21)101(01)  
EXTERNAL WALL /  
CAVITY PARTY WALL JUNCTION

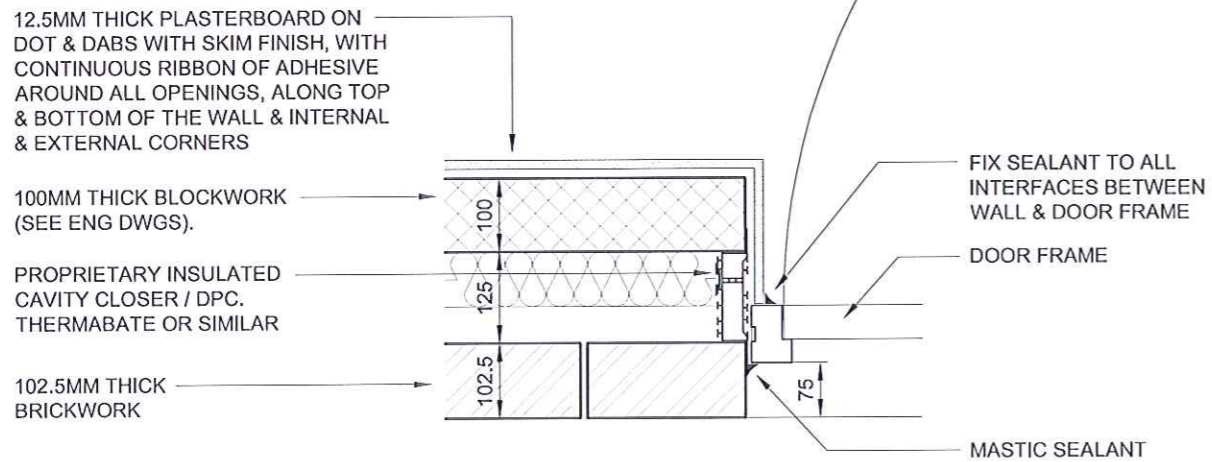

(21)101(03)  
HORIZONTAL SECTION  
AT DOOR

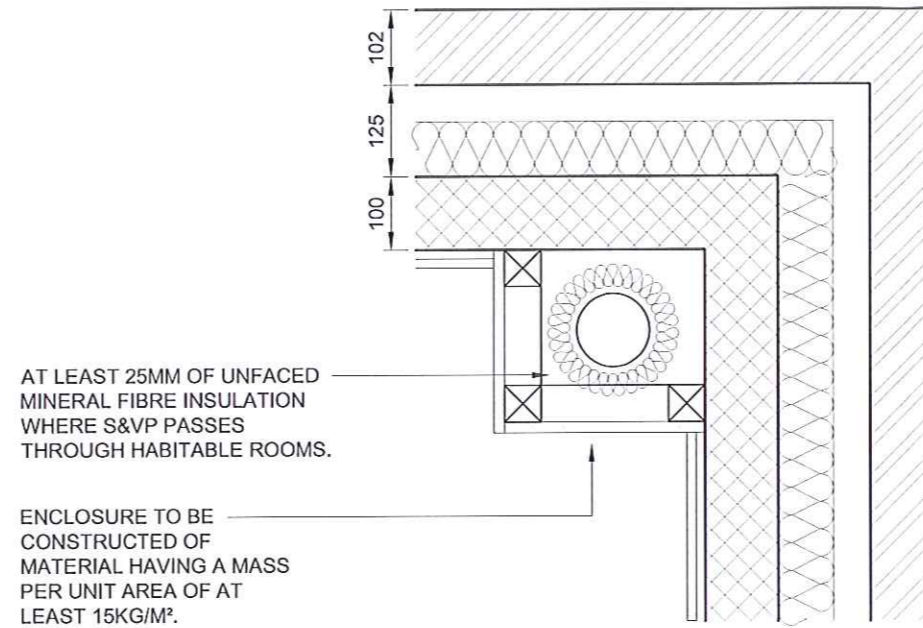

(21)101(02)  
TYPICAL SWP DETAIL

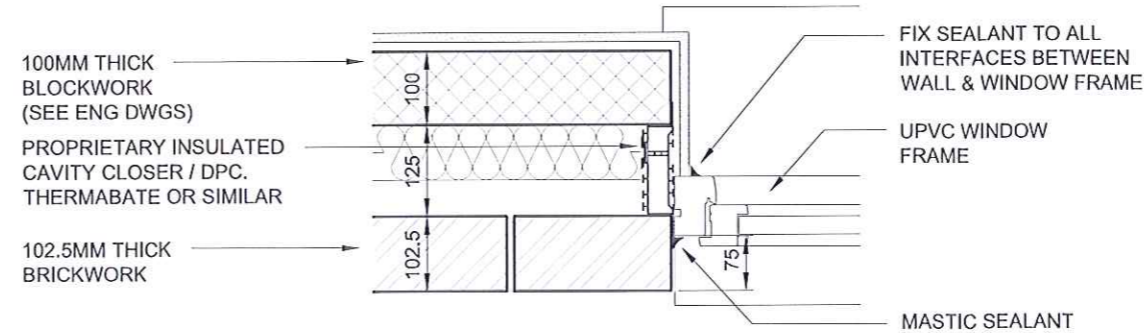

(21)101(04)  
HORIZONTAL SECTION  
AT WINDOW

NOTES

1. Do not scale from this drawing. All dimensions must be checked on site by the Contractor prior to the commencement of any fabrication or building works. Where applicable, dimensions and details are to be read in conjunction with specialist consultants' drawings and/or other specifications; any disparity is to be brought to the attention of contractor prior to the commencement of any fabrication or building works.



REVISIONS

This design is copyright ©

**Tolent**

PROP'D FAMILY HOUSING  
SCRAPER LANE  
STAINSACRE, N.YORKS

EXTERNAL WALLS  
HORIZONTAL DETAILS

Drawn: JMM Scale: 1:10 @ A3  
Date: APR 12 Checked: GJ

**brewsterbye architects**

5 NORTH HILL ROAD  
HEADINGLEY  
LEEDS  
LS6 2EN

Telephone: 0113 2756000  
Facsimile: 0113 2844250  
e-mail: info@brewsterbye.co.uk

Dwg No: 422/01(21)101 B



**NOTES**

1. Do not scale from this drawing. All dimensions must be checked on site by the Contractor prior to the commencement of any fabrication or building works. Where applicable, dimensions and details are to be read in conjunction with specialist consultants' drawings and/or other specifications; any disparity is to be brought to the attention of contractor prior to the commencement of any fabrication or building works.

I/M/N/P/A  
 14.03.22 MB

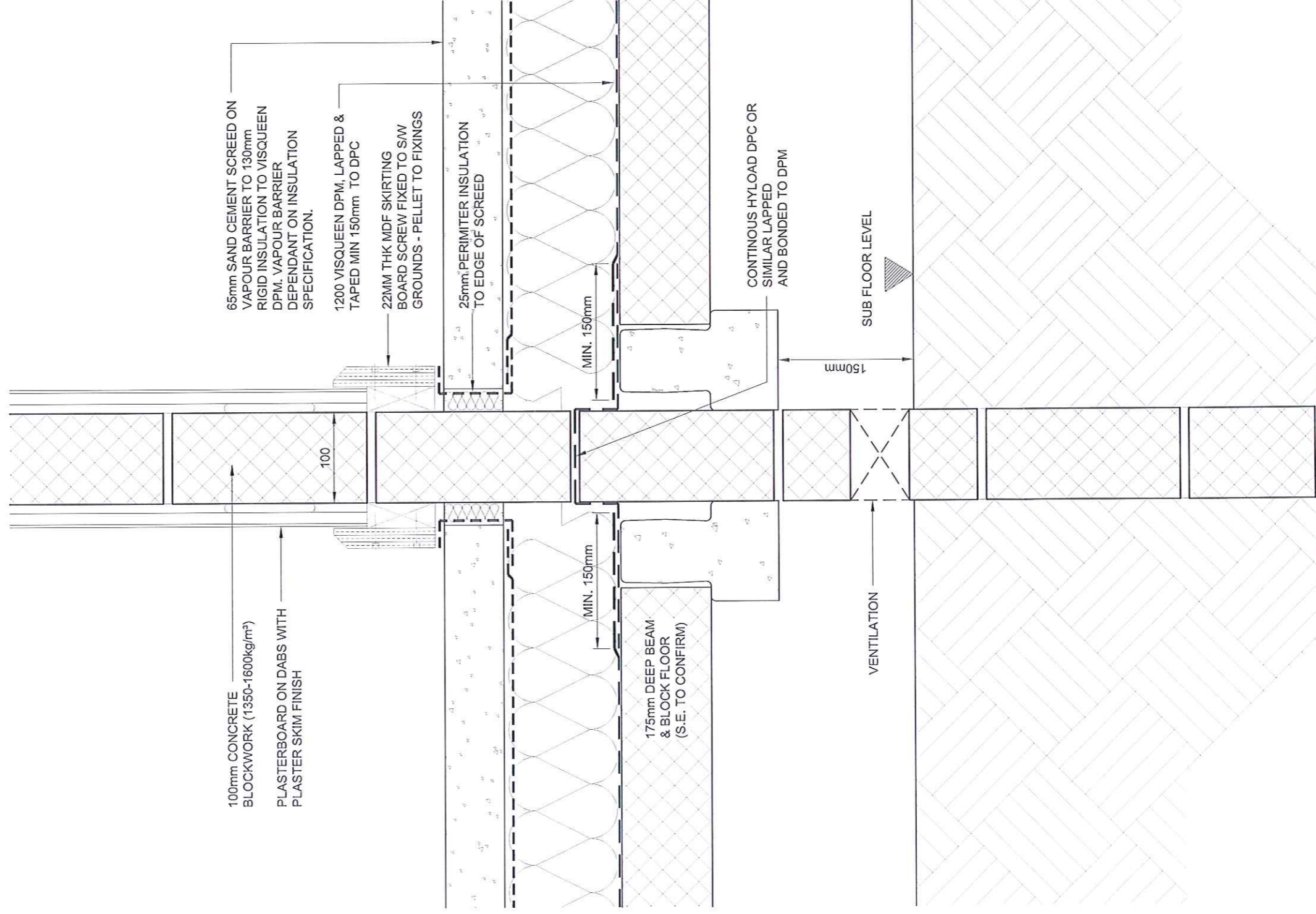

<b>STAGE 1</b> Information/ Comments	✓
<b>STAGE 2</b> Construction	

REVISIONS  
This design is copyright. ©



**Tolent**

PROP'D FAMILY HOUSING  
SCRAPER LANE  
STAINACRE, N.YORKS.

**INTERNAL BLOCKWORK WALL/  
GROUND FLOOR JUNCTION**

Drawn: JMM      Scale: 1:5 @ A3  
 Date: APR 12      Checked: MB

**brewsterbye** architects

5 NORTH HILL ROAD  
 HEADINGLEY  
 LEEDS  
 LS6 2EN

Telephone: 0113 2744000  
 Fax: 0113 2644200  
 Email: info@brewsterbye.co.uk

Dwg No: 422/01(22)001 B



**NOTES**

1. Do not scale from this drawing. All dimensions must be checked on site by the Contractor prior to the commencement of any fabrication or building works. Where applicable, dimensions and details are to be read in conjunction with specialist consultants' drawings and/or other specifications; any disparity is to be brought to the attention of contractor prior to the commencement of any fabrication or building works.

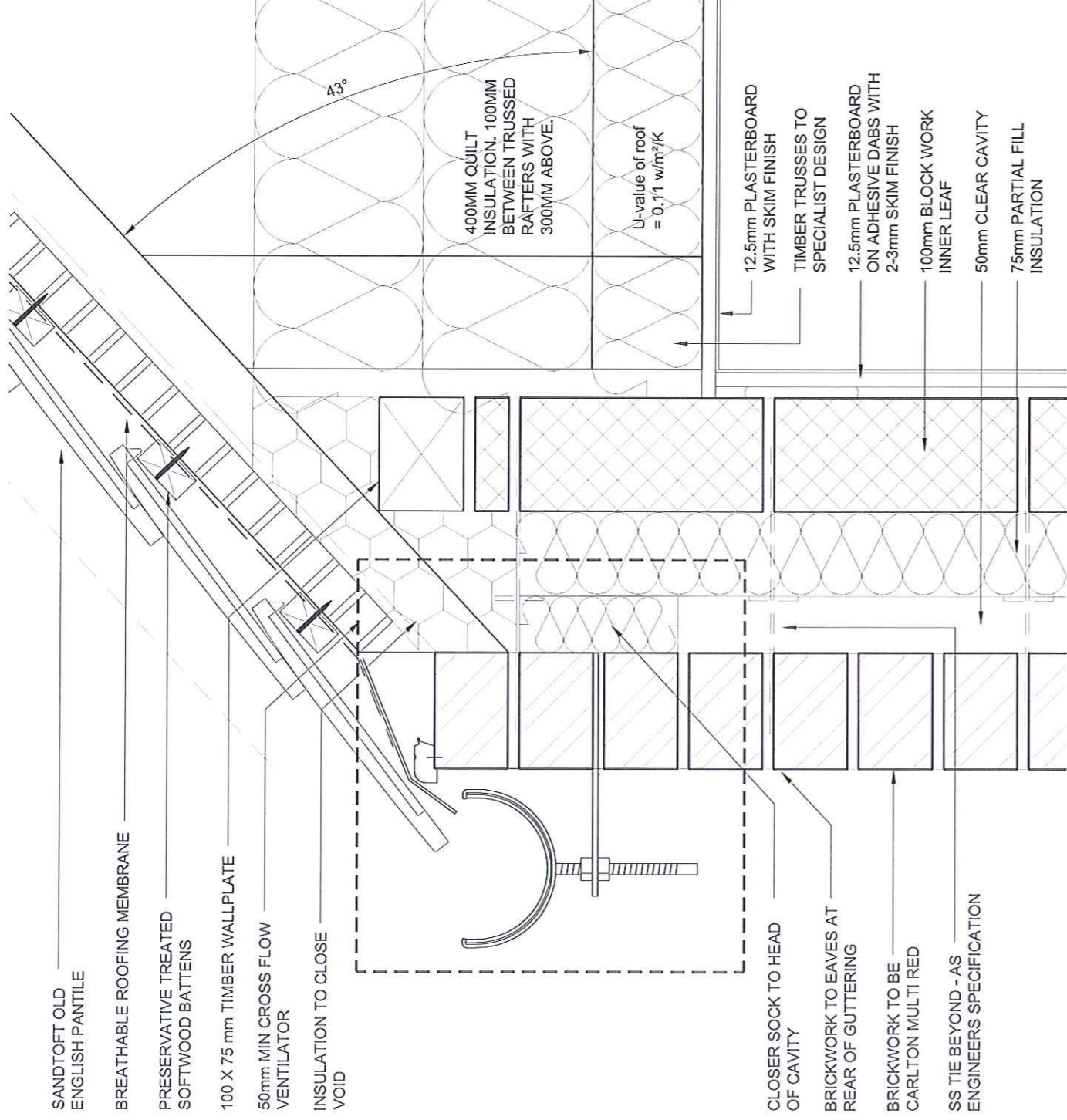

**SECTION**  
SCALE 1:5

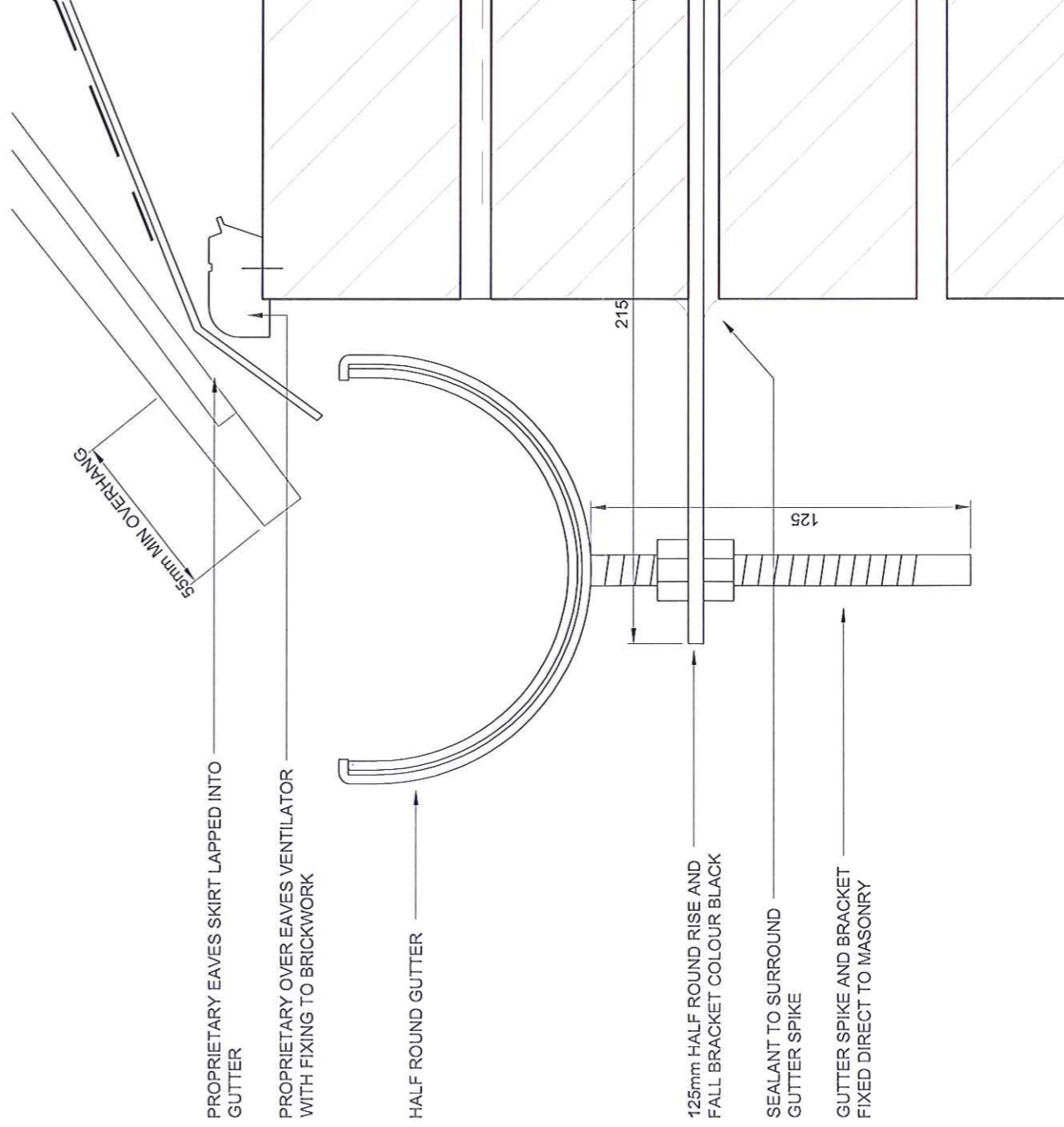

**SECTION**  
SCALE 1:2

<b>STAGE 1</b>	Information/ Comments	✓
<b>STAGE 2</b>	Construction	

REVISIONS

This design is copyright ©



**Tolent**

PROP'D FAMILY HOMES  
SCRAPER LANE

STAINSACRE, N.YORKS.

**ROOF CONSTRUCTION  
EAVES AND GUTTER  
DETAIL**

Drawn: JMM Scale: 1:5 @ A3  
Date: APR 2012 Checked: GJ



Dwg No: 422/01(27)001 C



**NOTES**

1. Do not scale from this drawing. All dimensions must be checked on site by the Contractor prior to the commencement of any fabrication or building works. Where applicable, dimensions and details are to be read in conjunction with specialist consultants' drawings and/or other specifications; any disparity is to be brought to the attention of contractor prior to the commencement of any fabrication or building works.

- DASHED LINE INDICATES COPING IN REAR
- UNDERLAY CUT TO PROVIDE VENTILATION
- PROPRIETARY VENTED RIDGE TILE
- BREATHER MEMBRANE ON RAFTERS
- SANDTOFT OLD ENGLISH PANTILE
- BATTENS
- ROOF TRUSSES TO SPECIALIST DESIGN

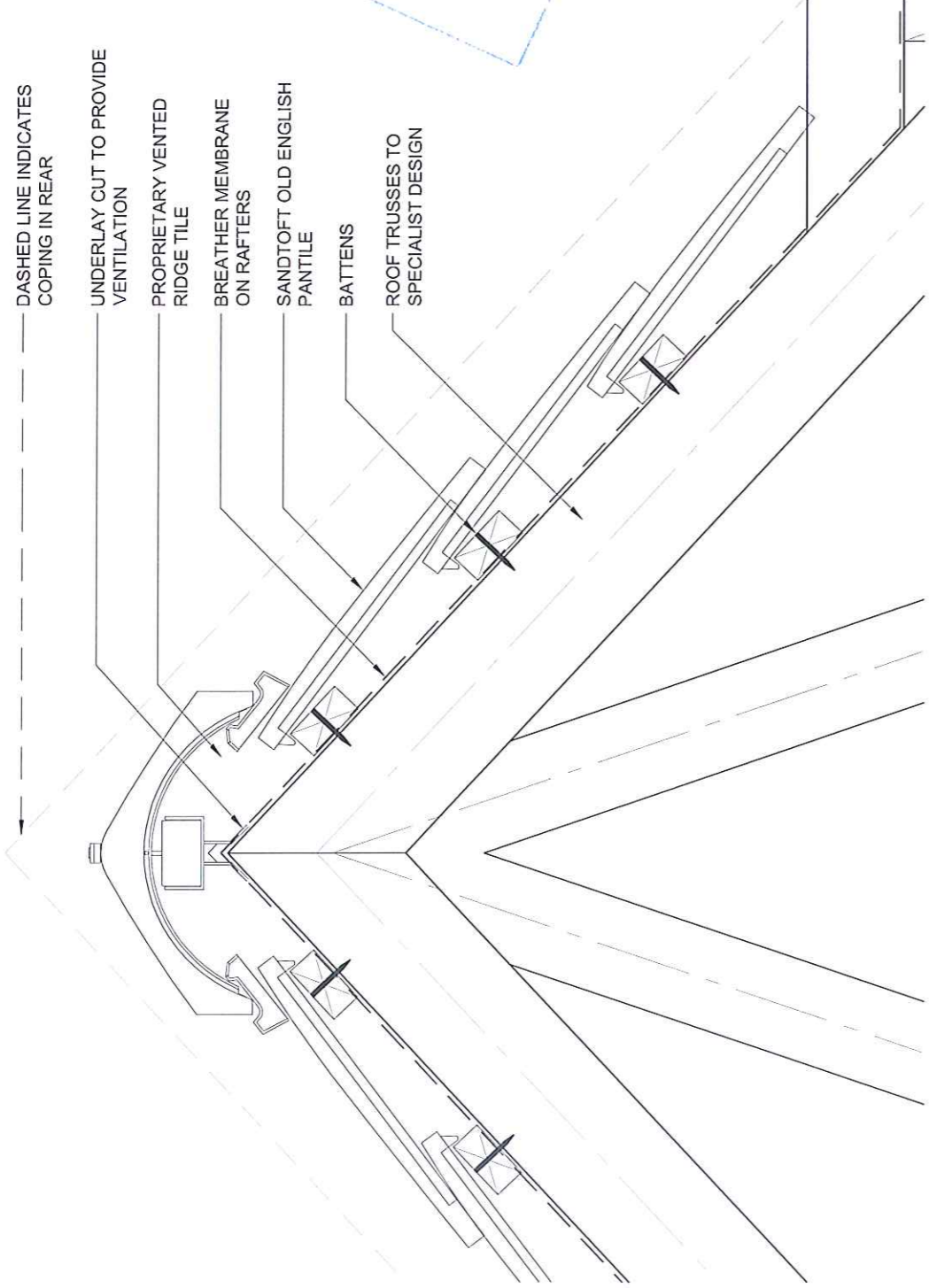

MUNWPA  
14-01-2012

**SECTION**  
SCALE 1:5

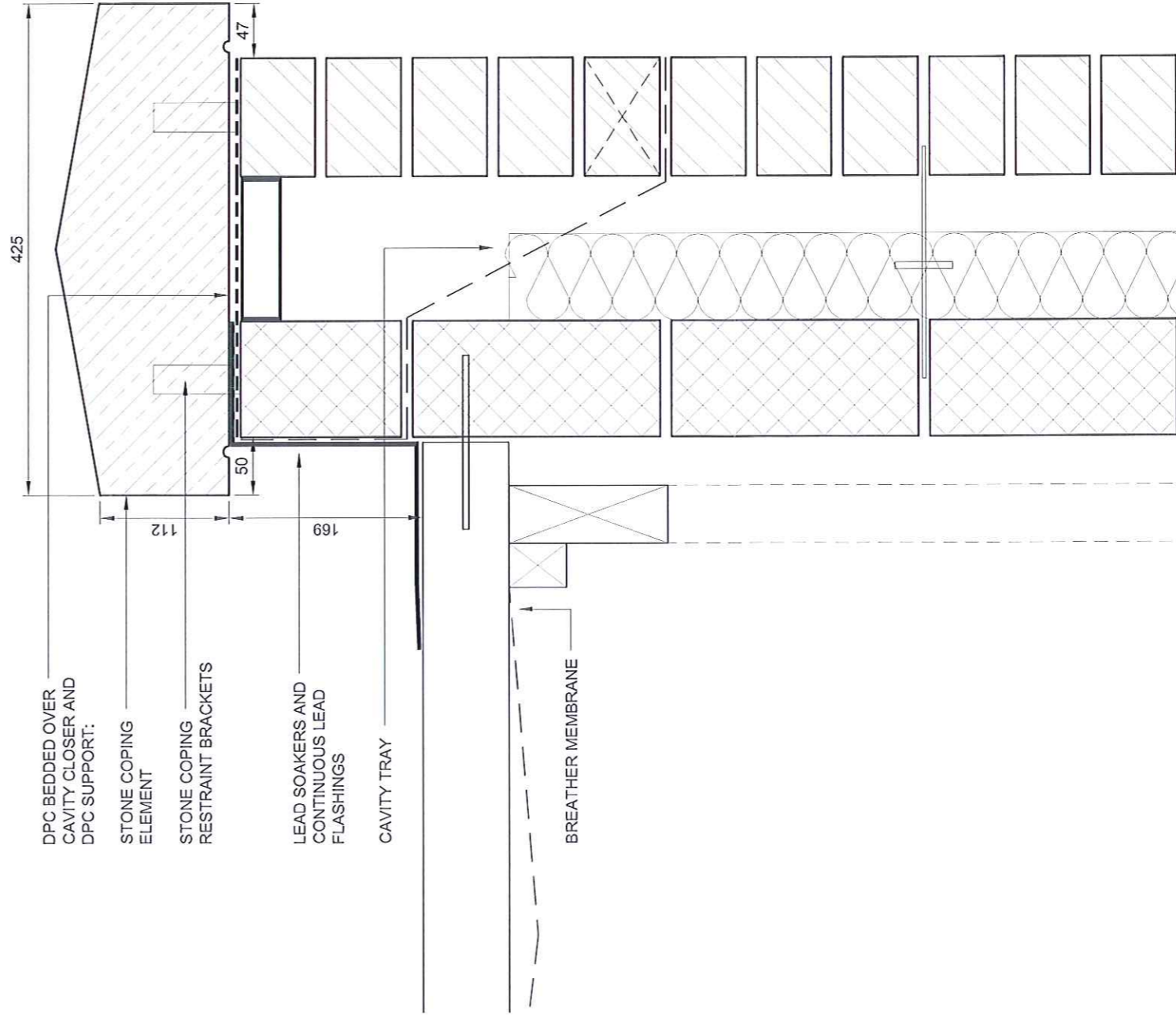

- DPC BEDDED OVER CAVITY CLOSER AND DPC SUPPORT:
- STONE COPING ELEMENT
- STONE COPING RESTRAINT BRACKETS
- LEAD SOAKERS AND CONTINUOUS LEAD FLASHINGS
- CAVITY TRAY
- BREATHER MEMBRANE

425

112

169

50

47

<b>STAGE 1</b>	Information/ Comments	✓
<b>STAGE 2</b>	Construction	

REVISIONS

This design is copyright. ©



**Tolent**

PROP'D FAMILY HOUSING  
SCRAPER LANE  
STAINSACRE, N.YORKS

**ROOF CONSTRUCTION  
RIDGE & COPING DETAIL**

Drawn: JMM Scale: 1:5 @ A3  
Date: APR 12 Checked: GJ

**rev .erbye architects**  
5 NORTH HILL ROAD  
HEADINGLEY  
LEEDS  
LS6 2EN  
0113 2944200  
info@revanderye.co.uk

**SECTION**  
SCALE 1:5

Dwg No: 422/01(27)002 C



**NOTES**

1. Do not scale from this drawing. All dimensions must be checked on site by the Contractor prior to the commencement of any fabrication or building works. Where applicable, dimensions and details are to be read in conjunction with specialist consultants' drawings and/or other specifications; any disparity is to be brought to the attention of contractor prior to the commencement of any fabrication or building works.

MIMPA  
 16/04/2012

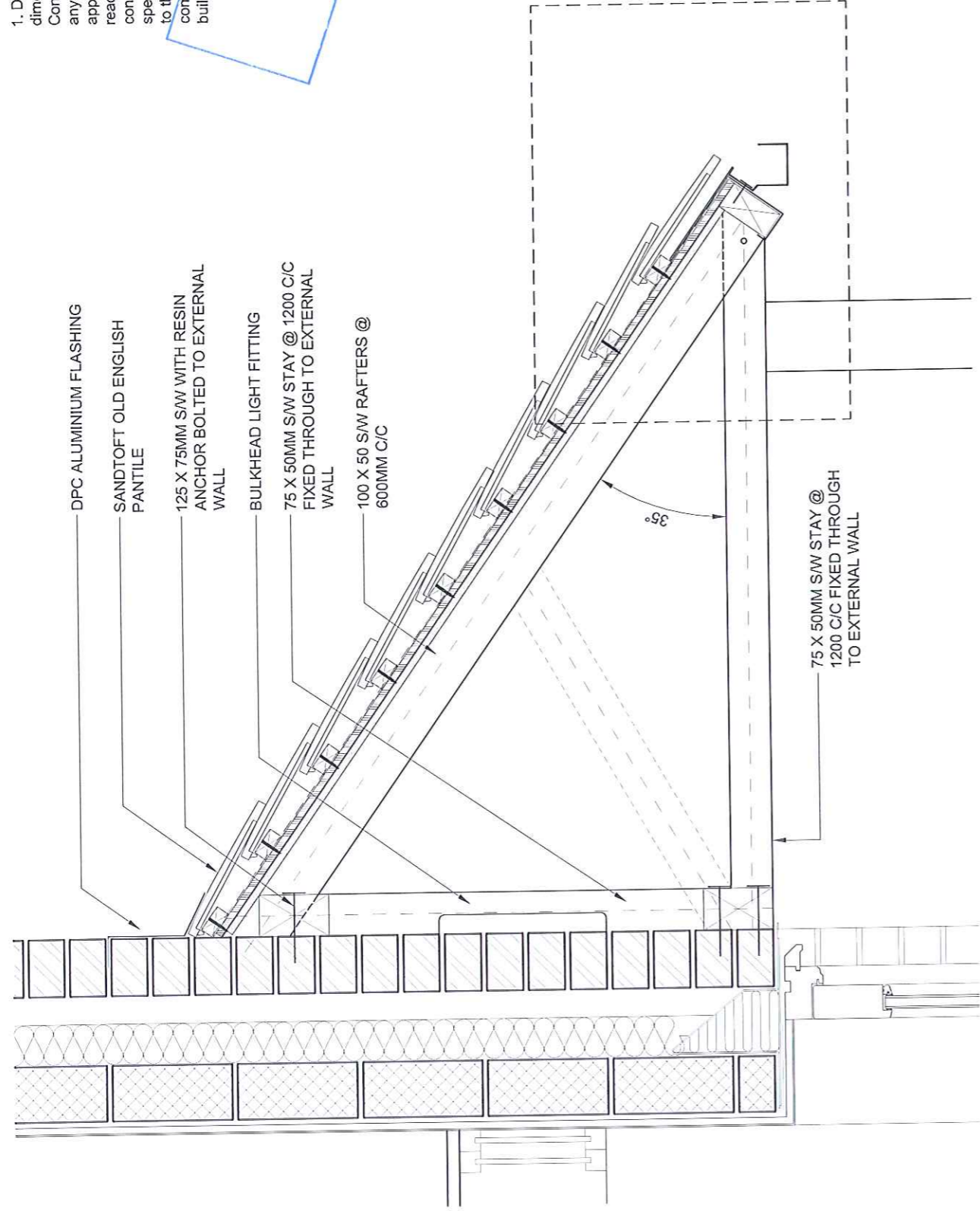

**SECTION**  
SCALE 1:10

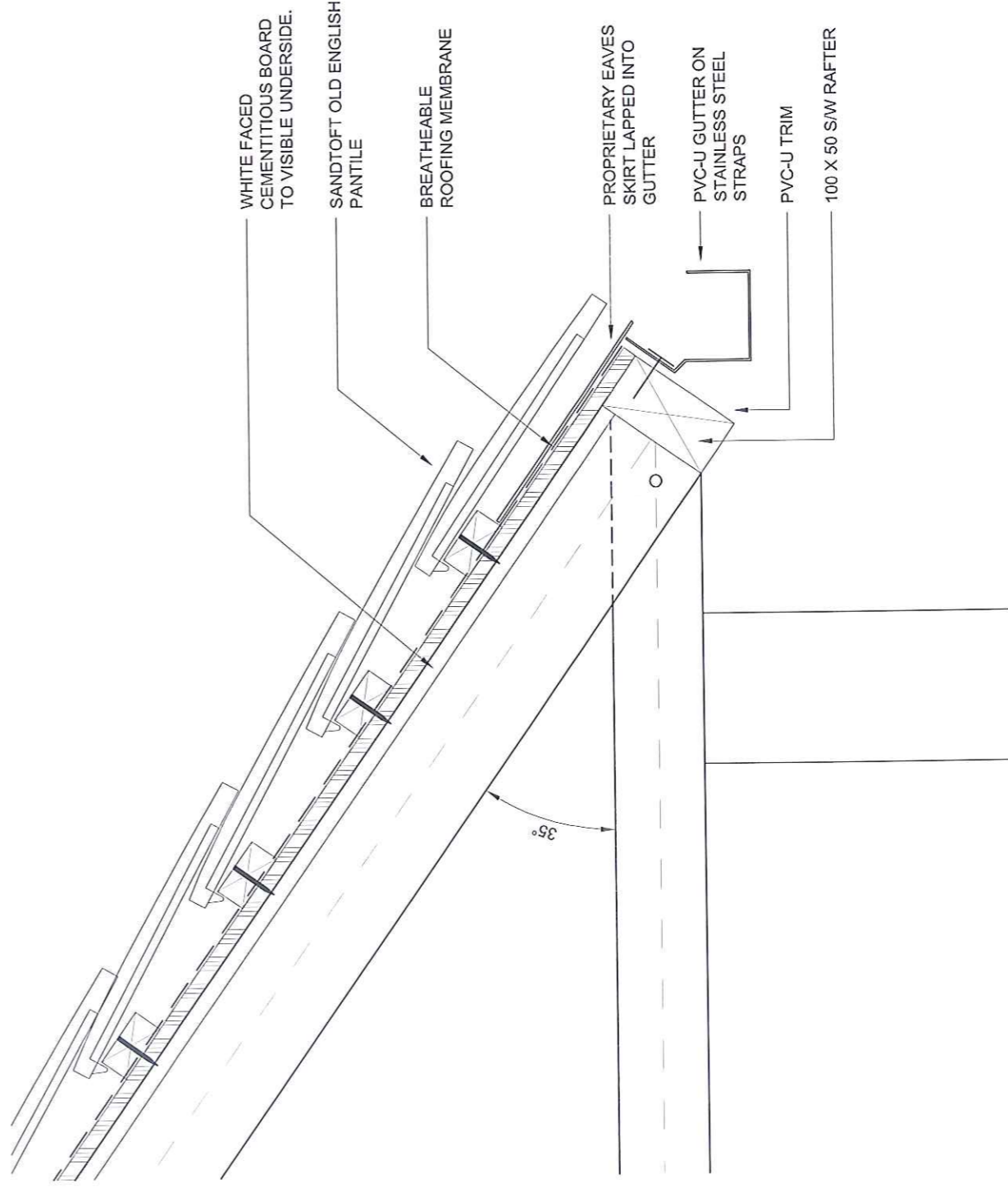

**SECTION**  
SCALE 1:5

<b>STAGE 1</b>	✓
Information/ Comments	
<b>STAGE 2</b>	
Construction	

REVISIONS  
The design is copyright. ©



**Tolent**

PROP'D FAMILY HOUSING  
SCRAPER LANE  
STAINESACRE, N.YORKS

**ROOF CONSTRUCTION  
CANOPY DETAIL**

Drawn: JMM    Scale: 1:5 @ A3  
Date: APR 12    Checked: GJ

**brewsterbye architects**

5 NORTH HILL ROAD  
HEADINGLEY  
LEEDS  
LS6 2EN  
Tel: 0113 2744000  
Fax: 0113 2744050  
e: info@brewsterbye.co.uk  
r: info@brewsterbye.co.uk

Dwg No: 422/01(27)003 C



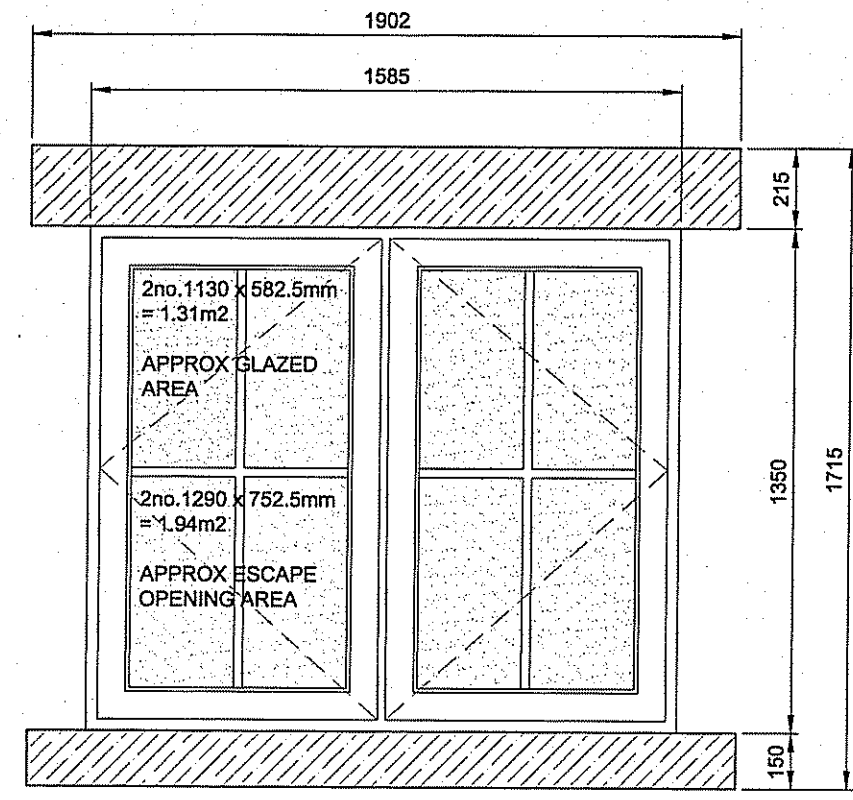

TYPE A  
6no. UNITS

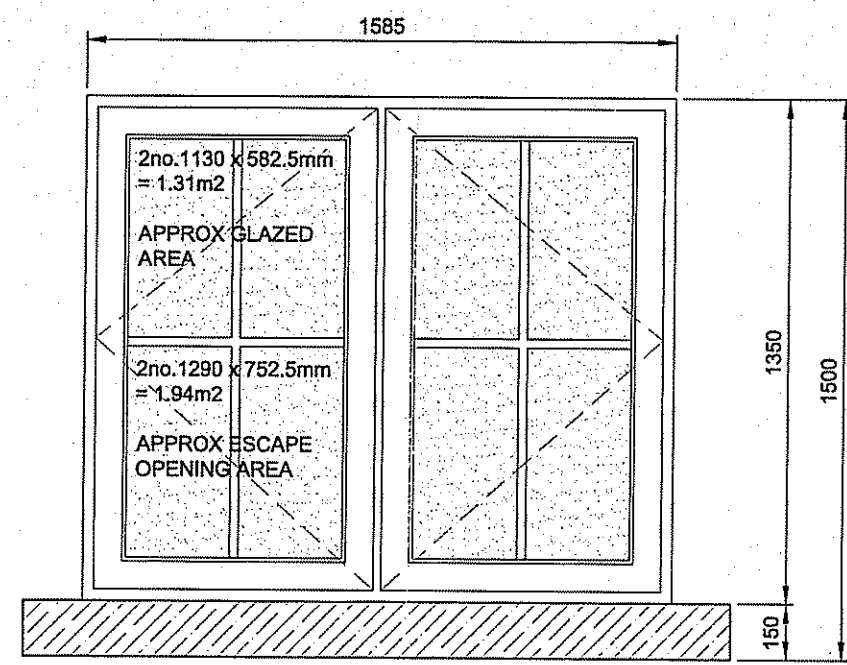

TYPE A2  
9 no. UNITS

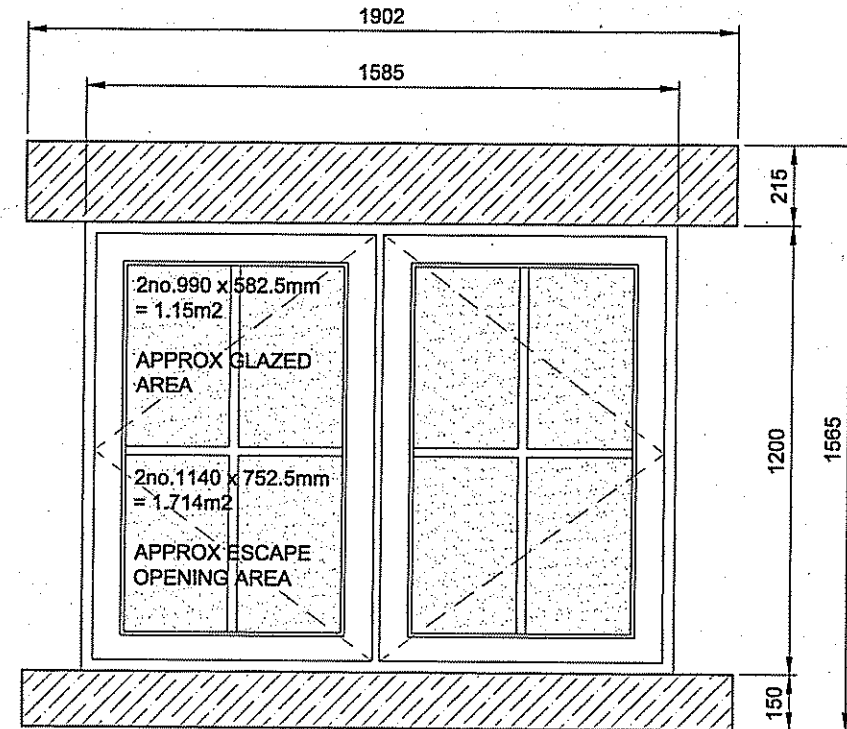

TYPE B  
6no. UNITS

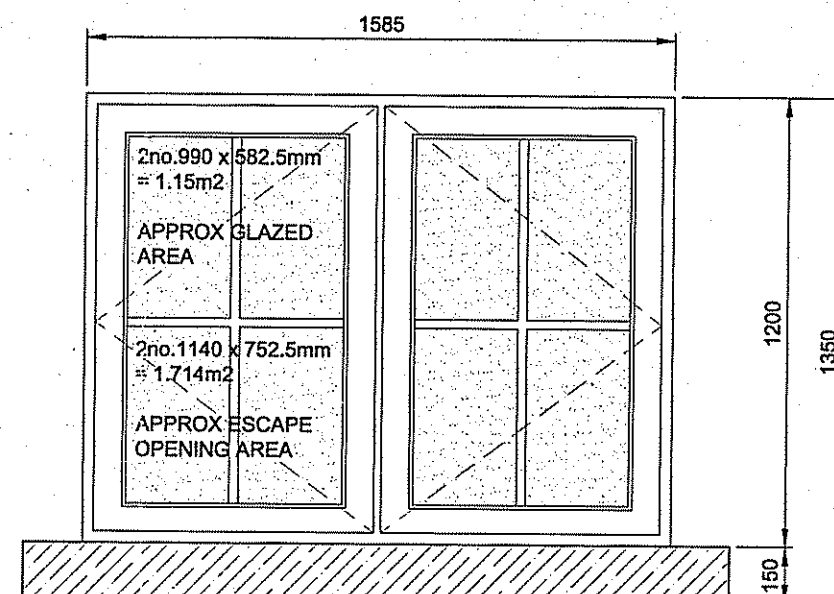

TYPE B2  
3no. UNITS

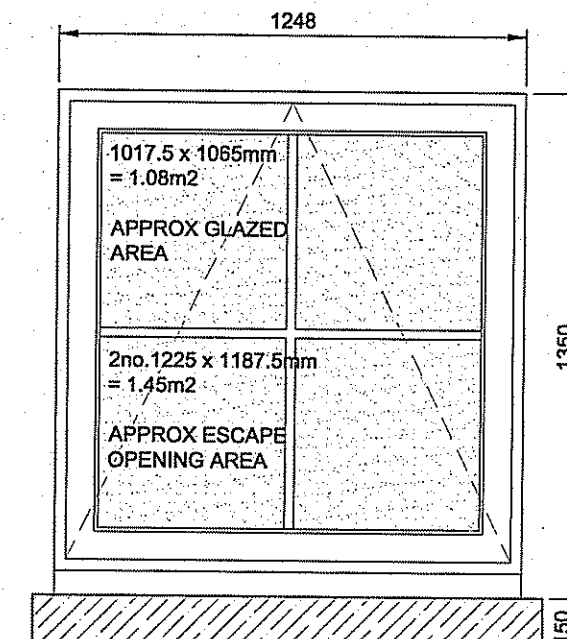

TYPE C  
3no. UNITS

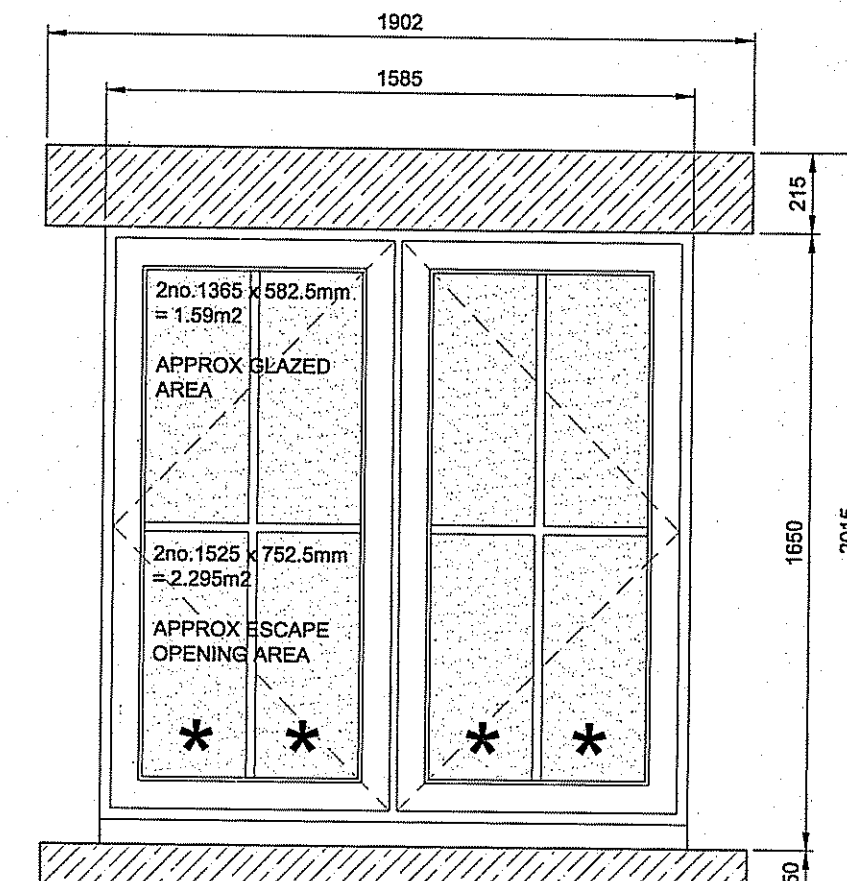

TYPE D  
3no. UNITS

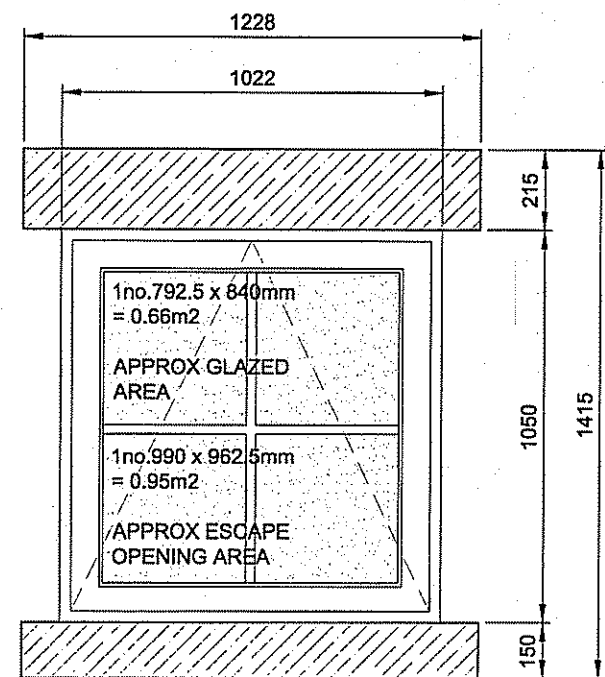

TYPE E  
3no. UNITS

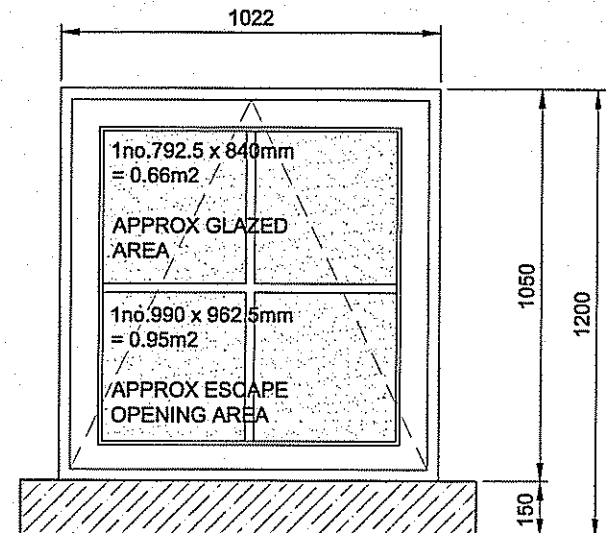

TYPE E2  
3no. UNITS

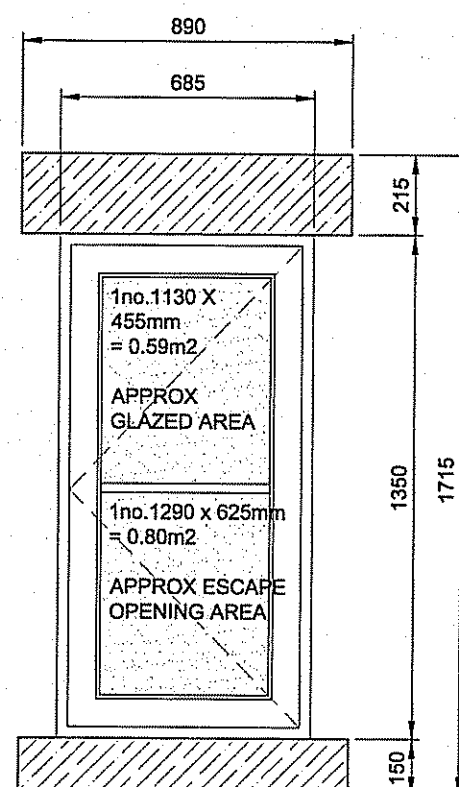

TYPE F  
3no. UNITS

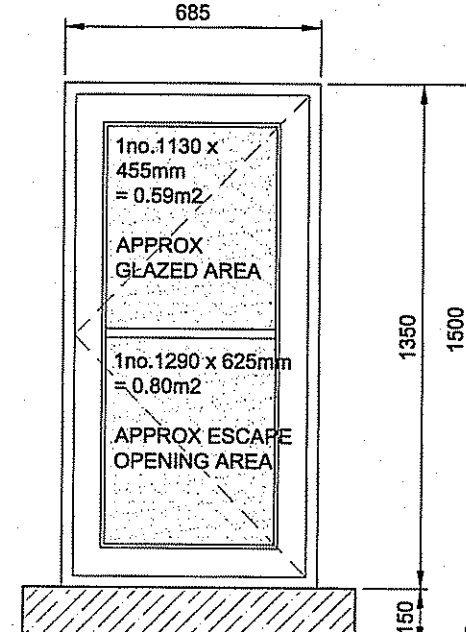

TYPE G  
6no. UNITS

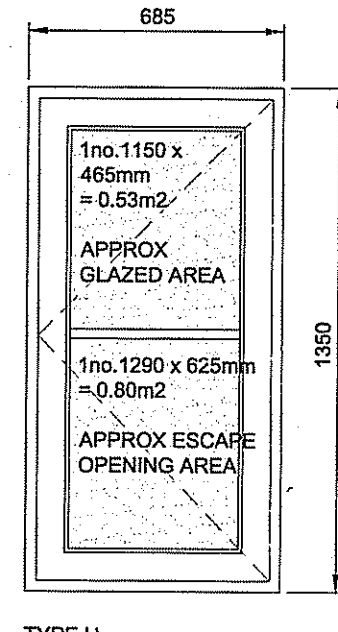

TYPE H  
3no. UNITS

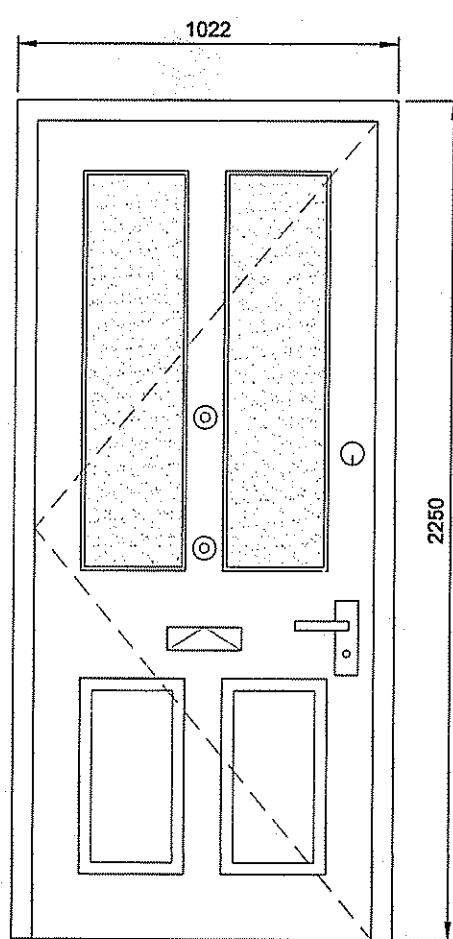

TYPE J  
6no. UNITS

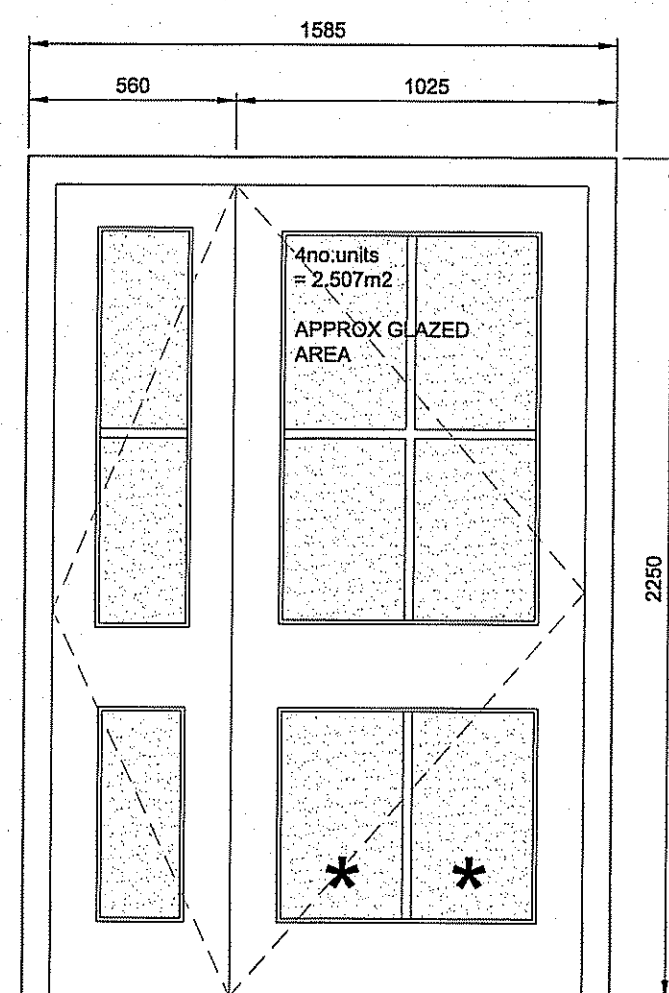

TYPE K  
6no. UNITS

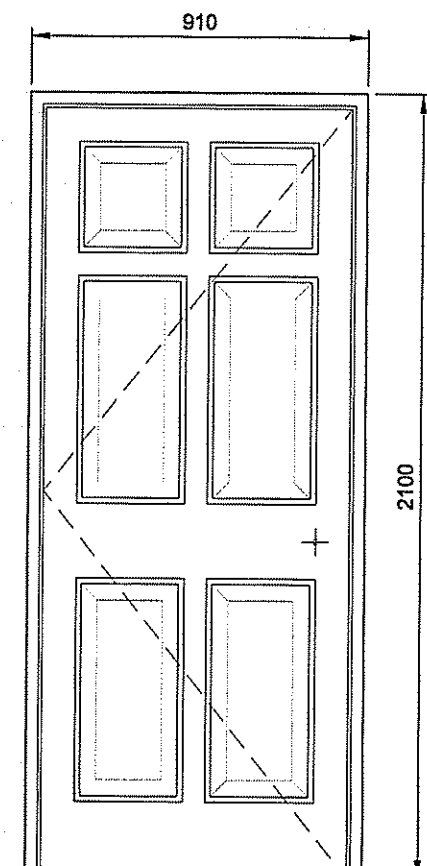

TYPE ID-A  
36no. UNITS

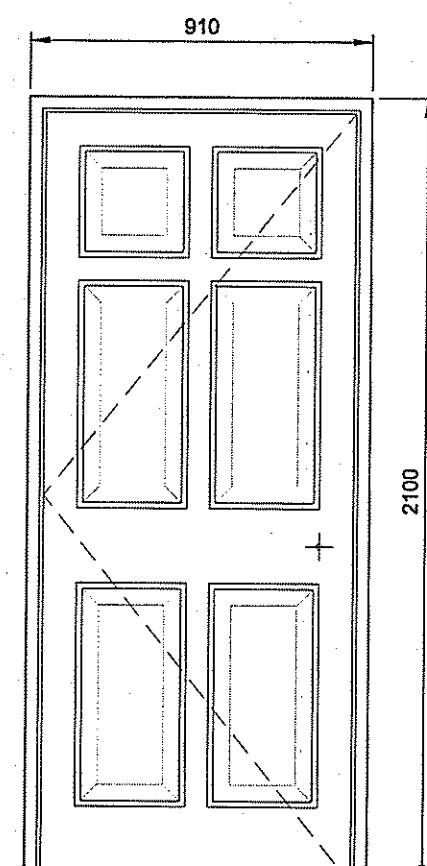

TYPE ID-A2  
12no. UNITS

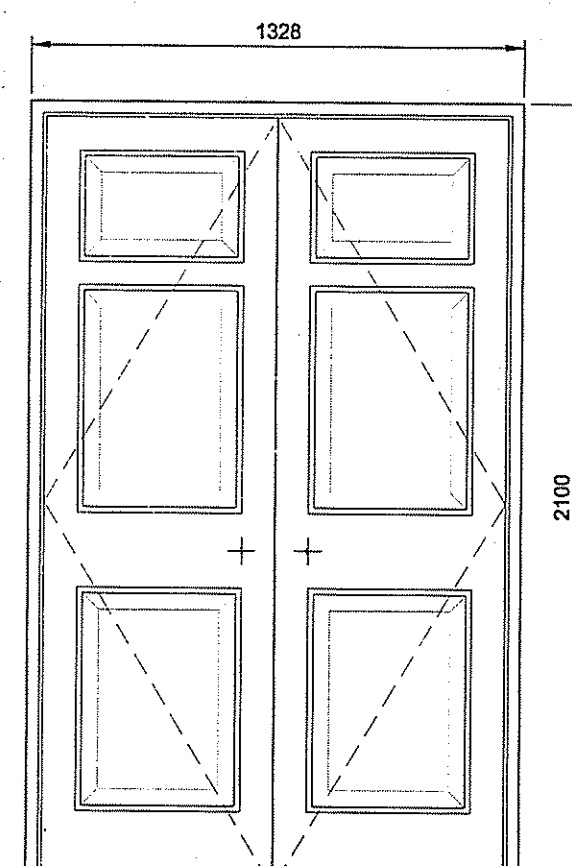

TYPE ID-B  
3no. UNITS

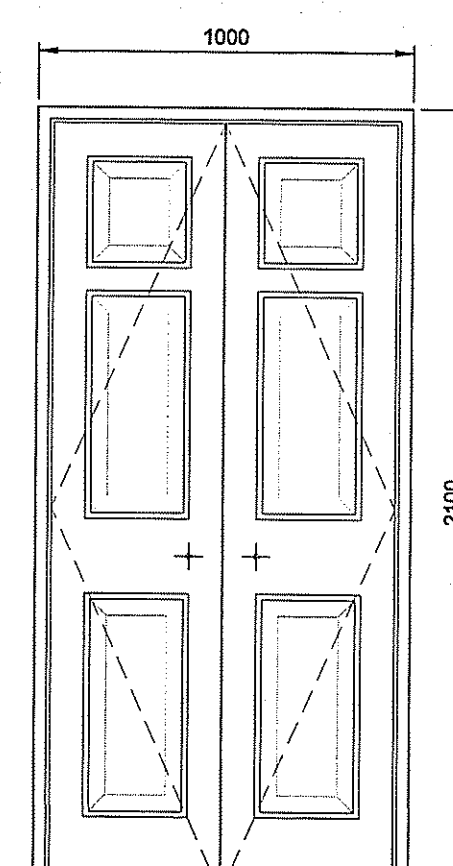

TYPE ID-C  
3no. UNITS

Entrance doors to be confirmed by TCL. Doors to have glazed aperture and be Secure by Design compliant.

Notes

Refer to window schedule document for more information.  
All dimensions to be checked on site prior to manufacture.  
Sizes indicated are structural opening sizes. Allowance to be made by window and door manufacturer for building in tolerance.  
All windows to achieve an overall U-value of 1.40W/m²K or better, and are to comply with parts F1 (ventilation) and N (glazing in critical locations) of the Building Regulations.  
Safety glazing to comply with BS2026, panels as indicated.  
All windows to have trickle vents (to the required level from building regulations) as per table.  
All windows and doors to comply with Secured by Design.  
All external doors to achieve an overall U-value of 1.40W/m²K or better, be PAS 23/24 and to have max. 15mm thresholds above finished floor level.  
Please refer to the Sanctuary Design Guide for more detailed information.  
Drawing to be read in conjunction with BBA Door and Window Schedule.  
All ground floor windows and doors to be laminated glass as per Secured by Design New Homes guidance item 21.11.

- Denotes the use of Natural York sandstone.
- Denotes glazing
- Denotes safety glazing in areas below 800mm and more than 300mm width as per Approved Document N1 (AFN1)

STAGE 1  
Information/ Comments

STAGE 2  
Construction

REVISIONS  
This design is copyright ©

**Tolent**  
PROP'D FAMILY HOUSING  
SCRAPER LANE  
STAINSLAKE, N.YORKS

DOOR AND WINDOW  
SCHEDULE

Drawn: JMM Scale: 1:20@A1  
Date: MAY 12 Checked: GJ

**brewsterbye architects**  
5 NORTH HILL ROAD  
HEADINGLEY  
LEEDS  
LS8 2EN  
0113 275 0000  
0113 254 4256  
info@brewsterbye.co.uk

Dwg No: 422/01(32)001 #